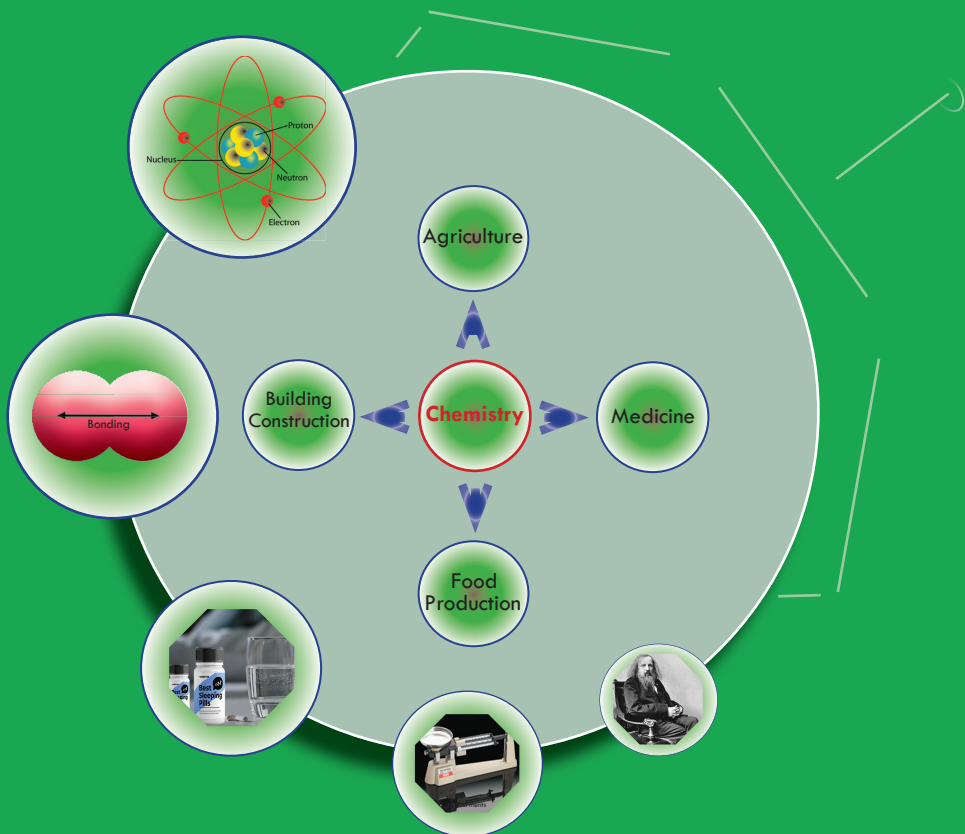




# CHEMISTRY

STUDENT TEXTBOOK

GRADE 9

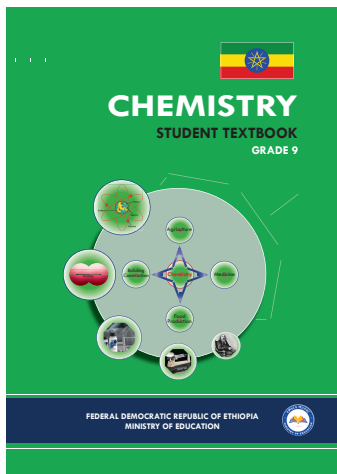


FEDERAL DEMOCRATIC REPUBLIC OF ETHIOPIA  
MINISTRY OF EDUCATION





## Students



This textbook is the property of your school. Take good care not to damage or lose it.

Here are 10 ideas to help take care of the book:

1. Cover the book with protective material, such as plastic, old newspapers or magazines.
2. Always keep the book in a clean dry place.
3. Be sure your hands are clean when you use the book.
4. Do not write on the cover or inside pages.
5. Use a piece of paper or cardboard as a bookmark.
6. Never tear or cut out any pictures or pages.
7. Repair any torn pages with paste or tape.
8. Pack the book carefully when you place it in your school bag.
9. Handle the book with care when passing it to another person.
10. When using a new book for the first time, lay it on its back. Open only a few pages at a time. Press lightly along the bound edge as you turn the pages. This will keep the cover in good condition.





# CHEMISTRY

## STUDENT TEXTBOOK GRADE 9

### Writers:

Sisay Tadesse (Ph.D.)  
Tegene Tesfaye (Ph.D.)

### Editors:

Tesfaye Semela (Ph.D.) (Curriculum Editor)  
Kenenisa Beresa (M.A.) (Language Editor)  
Ahmed Awel (M.Sc.) (Content Editor)

### Illustrator:

Abinet Tilahun (M.Sc.)

### Designer:

Konno B. Hirbaye (M.Sc.)

### Evaluators:

Legesse Adane (Ph.D.) (Reviewer)  
Nega Gichile (B.Sc., M.A.) (Evaluator)  
Sefiw Melesse (M.Sc.) (Evaluator)  
Tolessa Mergo (B.Sc., M.Sc.) (Evaluator)



**Federal Democratic Republic of Ethiopia**  
**Ministry of Education**



**Hawassa University**

First Published xxxxx 2022 by the Federal Democratic Republic of Ethiopia, Ministry of Education, under the General Education Quality Improvement Program for Equity (GEQIP-E) supported by the World Bank, UK's Department for International Development/DFID-now merged with the Foreign, Common wealth and Development Office/FCDO, Finland Ministry for Foreign Affairs, the Royal Norwegian Embassy, United Nations Children's Fund/UNICEF), the Global Partnership for Education (GPE), and Danish Ministry of Foreign Affairs, through a Multi Donor Trust Fund.

© 2022 by the Federal Democratic Republic of Ethiopia, Ministry of Education. All rights reserved. The moral rights of the author have been asserted. No part of this textbook reproduced, copied in a retrieval system or transmitted in any form or by any means including electronic, mechanical, magnetic, photocopying, recording or otherwise, without the prior written permission of the Ministry of Education or licensing in accordance with the Federal Democratic Republic of Ethiopia as expressed in the *Federal Negarit Gazeta*, Proclamation No. 410/2004 - Copyright and Neighboring Rights Protection.

The Ministry of Education wishes to thank the many individuals, groups and other bodies involved – directly or indirectly – in publishing this Textbook. Special thanks are due to Hawassa University for their huge contribution in the development of this textbook in collaboration with Addis Ababa University, Bahir Dar University and Jimma University.

Copyrighted materials used by permission of their owners. If you are the owner of copyrighted material not cited or improperly cited, please contact the Ministry of Education, Head Office, Arat Kilo, (P.O.Box 1367), Addis Ababa Ethiopia.

**Photo Credit:**

**Printed by:**

PRINTING

**P.O.Box:**

ETHIOPIA

Under Ministry of Education Contract no.:

**ISBN:** 978-999944-2-046-9

# CONTENTS

## **Unit 1 : CHEMISTRY AND ITS IMPORTANCE** **1**

1.1	Definition and Scope of Chemistry	2
1.2	Relationship between Chemistry and Other Natural Sciences	7
1.3	The Role Chemistry Plays in Production and in the Society	9
1.4	Some Common Chemical Industries in Ethiopia	12
	Unit Summary	15
	Review Exercise	16

## **Unit 2: MEASUREMENTS AND SCIENTIFIC METHODS** **19**

2.1	Measurements and Units in Chemistry	20
2.2	Chemistry as Experimental Science	37
	Unit Summary	50
	Review Exercise	50

## **Unit 3: STRUCTURE OF THE ATOM** **53**

3.1	Historical Development of the Atomic Theories of Matter	54
3.2	Fundamental Laws of Chemical Reactions	58
3.3	Atomic Theory	66
3.4	Discoveries of Fundamental Subatomic Particles and the Atomic Nucleus	71
3.5	Composition of an Atom and the Isotopes	87
	Unit Summary	103
	Review Exercise	107



## **Unit 4: PERIODIC CLASSIFICATION OF ELEMENTS** **111**

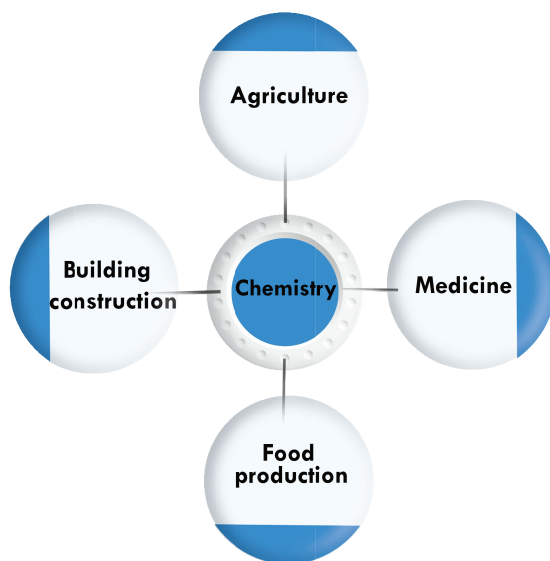
4.1	Historical Development of Periodic Classification of the Elements	113
4.2	Mendeleev's Classification of the Elements	116
4.3	The Modern Periodic Table	120
4.4	The Major Trends in the Periodic Table	128
	Unit Summary	140
	Review Exercise	141



## **Unit 5: CHEMICAL BONDING** **143**

5.1	Chemical Bonding	144
5.2	Ionic Bonding	146
5.3	Covalent Bonding	157
5.4	Metallic Bonding	171
	Unit Summary	175
	Review Exercise	178

# UNIT 1



## CHEMISTRY AND ITS IMPORTANCE

### Unit Outcomes

**After completing the unit, you will be able to**

- ☞ define chemistry;
- ☞ describe its' scope;
- ☞ discuss the relationships between chemistry with physics biology, medicine geology and other subjects;
- ☞ describe the application of chemistry in the field of agriculture, medicine, food production and building construction;
- ☞ name some common chemical industries in Ethiopia and their product.





### Start-up Activity

Make groups and discuss on the following questions and present your discussion points to the class.

1. What do you think that the following materials are made of?
  - ☞ the air you breath,
  - ☞ the water you drink,
  - ☞ the cloth you wear, and
  - ☞ the food you eat?
2. Why is everything in this world changing from time to time?
3. Is it important to know the materials from which everything is made up of? Why?
4. Mention some of the materials you are using commonly. Did you know who manufactured them?

Since chemistry is so fundamental to our world, it plays a role in everyone's lives and touches almost every aspect of our existence in some way. Chemistry is essential for meeting our basic needs such as food, clothing, shelter, health, energy, and clean air, water, and soil. The question is how?

In this unit, the definition and the scope of chemistry, the relationship between chemistry and other natural sciences, the role it plays in production and in the society, and some common chemical industries in Ethiopia are presented thoroughly.

## 1.1 Definition and Scope of Chemistry

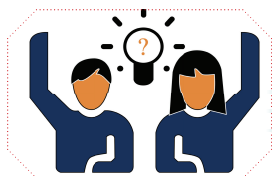
In this section two aspect of chemistry are going to be dealt with. The first is definition of chemistry which will be followed by the scope of chemistry. We shall begin by defining chemistry first.

### 1.1.1 Definition of Chemistry

At the end of this section, you will be able to define chemistry.

Students, form a group of three or four and discuss the question given below. Present your discussion points to the class when asked by your teacher.

1. Did you know what the composition of the salt you are adding to your meal is?



### Activity 1.1

2. What do you think will happen to the sugar crystals when you add a teaspoon of it in a cup of tea and stir it?
3. How can you distinguish table salt from sugar?
4. What happens to the wood when you burn it?

**Chemistry** is the science that deals with the properties, composition, and structure of substances (elements and compounds), the transformations they undergo, and the energy that is released or absorbed during these processes.

A **substance** is a particular kind of matter with uniform properties. Example, gold, silver, water, soap, table salt, etc (**Figure 1.1**).

**Matter** is a physical substance in general, that which occupies space and possesses rest mass, especially as distinct from energy. Example, book, pencil, television, stool, etc.

The **property** of a substance is its attribute, quality, or characteristic. Every substance, in the universe in which we live, has its own properties by which we can distinguish it from other substances. This is because every substance has its own unique composition and structure. Example, water is a substance that has no color, taste, and shape.

**Composition** is the nature of something's ingredients or constituents; how a whole or mixture is made up. Example, table salt is chemically composed of the element sodium and chlorine. The stainless-steel spoons are solid solution (alloy) of chromium, carbon and other elements.

The arrangement and relationships between the parts or elements of something complex is known as its **structure**. Example, the school buildings are made up of roof, ceiling, doors, windows, walls, and floor arranged in a certain order. The arrangement of each of these parts are known as the structure of the school building.



Salt



Sulphur



Gold



Silver

**Figure 1.1** Substances around us.

Every substance in our environment is continuously changing from time to time due to both external and internal forces. Due to this change, it transforms from one form into the other. The **transformation** of a substance is a marked change in form, nature, or appearance. These transformations are accompanied by energy changes.

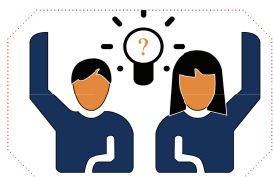


### Exercise 1.1

1. Define the term chemistry.
2. Explain the meaning of the following phrases.
  - ☞ property of a substance
  - ☞ composition of a substance
  - ☞ structure of a substance
  - ☞ transformation of a substance

### 1.1.2 Scope of Chemistry

At the end of this section, you will be able to explain the scope of chemistry.



### Activity 1.2

Students, form groups of three or four. Discuss the following questions and present your discussion points to the class.

1. How do you clean: your cloth when it gets dirt, the dishes after eating meal, and your hand?
2. How does the butcher in your town measure the weight of beef before selling it?
3. Do you know how the clothes and shoes you wear, the tyres of automobiles, the different medicines you take when you are ill, and the glasses in the windows of your house are made?
4. What happens to the food in your body, after you ate it?

The study of modern chemistry has many branches, but can generally be broken down into five main disciplines, or areas of study:

- Physical chemistry:** Physical chemistry is the study of macroscopic properties, atomic properties, and phenomena in chemical systems. A physical chemist may study such things as the rates of chemical reactions, the energy transfers that occur in reactions, or the physical structure of materials at the molecular level.
- Organic chemistry:** Organic chemistry is the study of substances containing carbon. Carbon is one of the most abundant elements on Earth and is capable of forming a tremendously vast number of chemicals (over twenty million so far). Most of the chemicals found in all living organisms are based on carbon.



- iii. **Inorganic chemistry:** Inorganic chemistry is the study of substances that, in general, are not primarily based on carbon. Inorganic chemicals are commonly found in rocks and minerals. One current important area of inorganic chemistry deals with the design and properties of materials involved in energy and information technology.
- iv. **Analytical chemistry:** Analytical chemistry is the study of the composition of matter. It focuses on separating, identifying, and quantifying chemicals in samples of matter. An analytical chemist may use complex instruments to analyze an unknown material in order to determine its various components.
- v. **Biochemistry:** Biochemistry is the study of chemical processes that occur in living things. Research may cover anything from basic cellular processes up to understanding disease states so that better treatments can be developed.

All of the aforementioned disciplines of Chemistry are highly engaged in taking measurements, making observations, and using them to come to conclusions. Chemistry is about looking for patterns in the way substances behave. Because living and non-living things are made of matter Chemistry affects all aspects of life and most natural events. The scope of Chemistry can be extended to explaining the natural world, preparing people for career opportunities, and producing informed patriot citizens.

The scope of chemistry includes agriculture, medicine food production, and building construction (**Figure 1.2**).



**Figure 1.2** Some chemical products.

Chemistry, however, is not only involved in providing useful substances in the areas of development and technology, but it can also result in very dangerous substances that can negatively affect human being's life and the environment (eg. fluorochloro hydrocarbons, oxides of nitrogen, carbon, and sulphur).



## Exercise 1.2

Provide correct answer for the following questions.

1. List down examples of chemicals or chemical products that are used in the following areas:

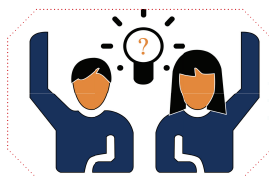
- ☞ Agriculture
- ☞ Medicine
- ☞ Food production
- ☞ Building construction

Hint: Refer **Figure 1.2** above.

2. Search on the internet, and write down some of the problems caused by dangerous chemicals affecting the environment.
3. Which of the problems you find in question #2 above are observed in your locality?
4. What do you think is the solution to the problem(s)? Remember that you are an Ethiopian citizen, and have the responsibility of protecting the nation from the problems caused due to chemical substances.

## 1.2 Relationship Between Chemistry and Other Natural Sciences

At the end of this section, you will be able to discuss the relationship of chemistry with physics, biology, medicine, geology and other subjects.

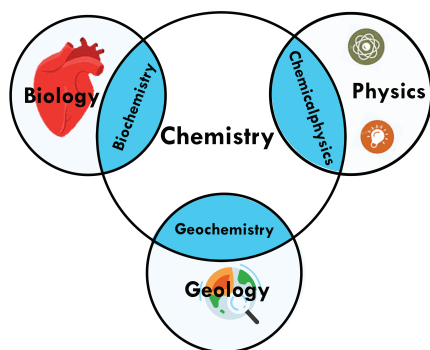


### Activity 1.3

Students, form groups of three or four, and discuss the following questions. Then, present your discussion points to the class, when asked by your teacher.

1. List down the subjects that are categorized under natural science.
2. In biology class you may studied about photosynthesis. Is it possible to explain photosynthesis without having the knowledge of a chemical reaction? Reason out why?

**Chemistry** is one branch of science. **Science** is the process by which we learn about the natural universe by observing, testing, and then generating models that explain our observations. Because the physical universe is so vast, there are many different branches of science (**Figure 1.3**). Thus, **biology** is the study of living things, and geology is the study of rocks and the earth. **Physics** is the branch of science concerned with the nature and properties of matter and energy.



**Figure 1.3** The relationships between natural sciences and chemistry.

Although we divide science into different fields, there is much overlap among them. For example, some biologists and chemists work in both fields so much that their work is called **Biochemistry**. **Biochemistry** is the study of the chemical processes occurring in living matter. To give you a specific example, there are chemists who are working on the isolation, characterization and biological activities of medicinal plants. Similarly, Geology and Chemistry overlap in the field called **Geochemistry**. **Geochemistry** is defined as the study of the processes that control the abundance, composition, and distribution of chemical compounds and isotopes in geologic environments. Chemistry and Physics overlap in the areas of atomic and small molecule properties. Both of them deal with matter and energy.

**Physical chemistry** is the branch of chemistry concerned with the application of the techniques and theories of physics to the study of chemical systems. **Chemical physics** is a sub discipline of chemistry and physics that investigates physicochemical phenomena using techniques from atomic and molecular physics and condensed matter physics; it is the branch of physics that studies chemical processes from the point of view of physics. Chemistry and Medicine are related in the area of **Medicinal chemistry**.

**Figure 1.3** shows how many of the individual fields of science are related. At some level, all of these fields depend on the matter as they all involve 'stuff'. Because of this, chemistry has been called the '**central science**' linking them all together.



### Exercise 1.3

Provide correct answer the following questions.

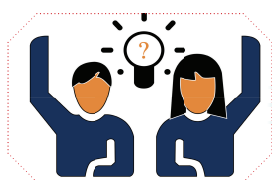
- What aspects of nature are studied in
 

<input type="checkbox"/> Physics?	<input type="checkbox"/> Geochemistry?
<input type="checkbox"/> Biology?	<input type="checkbox"/> Biochemistry?
<input type="checkbox"/> Geology?	<input type="checkbox"/> Physical chemistry?
- What are the regions of an overlap between
 

<input type="checkbox"/> Chemistry and biology?	<input type="checkbox"/> Chemistry and geology?
<input type="checkbox"/> Chemistry and physics?	

## 1.3 The Role Chemistry Plays in Production and in the Society

At the end of this section, you will be able to describe the application of chemistry in the field of agriculture, medicine, food production and building construction.



### Activity 1.4

Students, form groups of two or three and discuss the questions below. Present your discussion points to the class when asked by your teacher.

1. What are the common types of fertilizers the Ethiopian farmers employ to increase their crop productivity?
2. Give some examples of household materials that are used for cleaning, baking 'diffo dabbo', disinfecting salad, preserving raw meat, and hair treatment.
3. What types of medications (traditional and modern) are used to treat the various diseases you know?
4. What are the common types of fuels that are sold in the gas stations?

There are many instances in your everyday life that involves the knowledge of chemistry, its applications, and its rules. Let us look at some of them one by one.

#### A. Agriculture

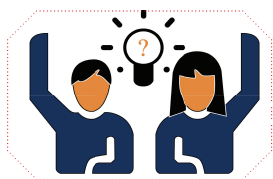
The study of chemistry has brought the world with chemical fertilizers such as calcium super phosphate, urea, ammonium sulphate, and sodium nitrate. These chemicals have assisted greatly in increasing the yield of fruits, vegetables, and other crops (**Figure 1.4**). Chemistry has been effective in the manufacture of pesticides, which have lessened the crop damage. Depending on the targeted pest, pesticides include fungicides, herbicides, and insecticides. Thus, we can supply to the ever-growing demand for food. Chemistry has also an important role in the manufacturing of better-quality plastic pipes for irrigation, and is commonly used in farming. This has massively increased irrigation resulting in a better climate in which the crops grow.

#### B. Food Production

Other than its great contribution in the production of different agricultural products, chemistry has led to the discovery of different kinds of food preservatives. These chemicals have greatly assisted to preserve food products for a longer period. It has given methods to test the presence of adulterants which ensure the supply of pure foodstuff. Consumers have benefited from new technologies that have increased their food's availability, appearance, nutritional contents and flavor. A local example of food processing and keeping it for a longer period of time is the preservation of raw meat “ቲንቢ”.



**Figure 1.4** Agricultural products.



### Activity 1.5

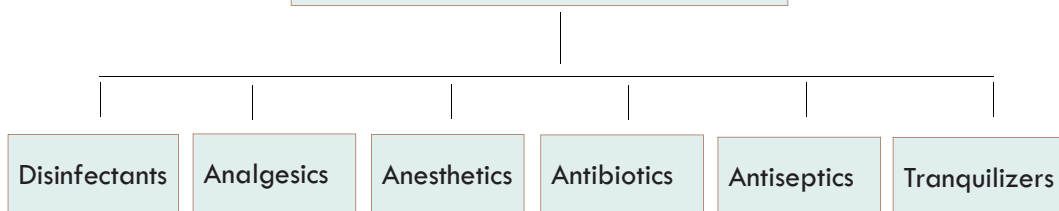
Students, form groups of two or three and discuss the questions below. Present your discussion points to the class when asked by your teacher.

1. What are the common pests that damage crops in your locality?
2. What are the common herbs that reduce the production of food in your locality?
3. What are the commercial and traditional pesticides and herbicides used by the local farmers?

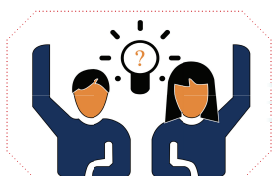
### C. Medicine

Chemistry has provided mankind with a large number of life-saving medicines. We could find a cure for dysentery and pneumonia as a result of the discovery of Sulphur drugs and penicillin. Besides this, life-saving drugs like cisplatin and Taxol are effective for cancer therapy, and AZT is used for AIDS victims. Although AZT does not cure HIV-AIDS, it fights the multiplication of the virus thereby prolonging the life of the victim. HIV-AIDS as we know is a pandemic that has no curative medication. We need to prevent ourselves from this killer disease by being Abstain, Be faithful or reduce the number of your sex partners, and/or use a Condom.

**Common Drugs Chemistry Provided**



- ☞ **Disinfectants:** To kill the microbe present in toilets, floors, and drains. The sanitizers we use for Covid-19 belong to this group.
- ☞ **Analgesics:** An analgesic or painkiller is any member of the group of drugs used to achieve analgesia, relief from pain.
- ☞ **Anesthetics:** Has made medical operations more and more effective via relieving pain.
- ☞ **Antibiotics:** To control infection and cure diseases.
- ☞ **Antiseptics:** To stop contamination of the wounds by bacteria.
- ☞ **Tranquillizers:** To reduce tension and bring about calm and peace to patients suffering from mental diseases.



**Activity 1.6**

Students, form groups of two or three and discuss the questions below. Present your discussion points to the class when asked by your teacher.

1. Search on the Internet or from other sources and find examples of analgesics, antibiotics, tranquilizers, antiseptics, disinfectants, anesthetics, and insecticides.
2. Describe the composition and preparation of hand disinfectant or hand sanitizer.

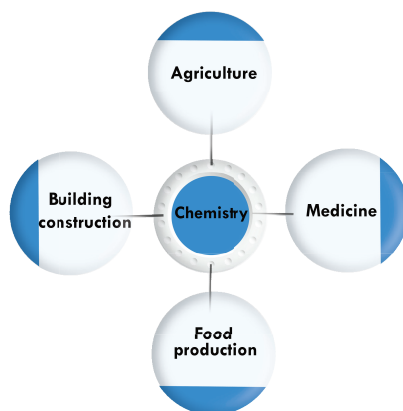
**D. Building Construction Materials**

By providing building resources such as glass, steel and cement, chemistry helps in the construction of safer houses and multi-story structures. It also helps in the construction of long-lasting and durable dams and bridges. The best example here could be the Grand Ethiopian Renaissance Dam (GERD) which is under construction in the Benishangul-Gumuz Region (**Figure 1.5**). The GERD is a 6,450 MW hydro power project nearing completion on the Blue Nile in Ethiopia, located about 30 km upstream of the border with Sudan. It will be the largest hydro power project in Africa.





**Figure 1.5** The Grand Ethiopian Renaissance Dam, Benishangul Gumuz Region, Ethiopia.



**Figure 1.6** The role of chemistry in different sectors.



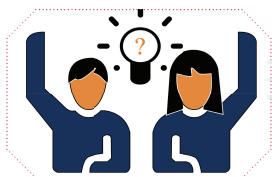
### Exercise 1.4

Provide correct answer for the following questions.

1. List down the role of chemistry in your locality. Draw a spider diagram of your own.
2. What problems, do you think, will be observed in the livelihood of the community in which you are living in the absence of enough knowledge of chemistry?
3. In your opinion, what further roles can chemistry play?

## 1.4 Some Common Chemical Industries in Ethiopia

At the end of this section, you will be able to name some common chemical industries found in Ethiopia and their products.



### Activity 1.7

Students, make groups of how two or three and do the following activities. Present your answers to the class when asked by your teacher.

1. List down some of the house hold chemicals?
2. Do you know which industry is producing them?
3. List down the common chemical industries (enterprises) found in your locality or in the vicinity of your town. Which chemicals or chemical products are they producing?

An **industry** is defined as an economic activity concerned with the processing of raw materials and the manufacture of goods in factories. It can also be interpreted as a group of companies that are linked based on their primary business activities. Individual companies are generally categorized into an industry based on their largest sources of revenue. The Ethiopian government is highly engaged in expanding industries in the past two decades. As part of this expansion several industrial parks have been under construction (**Figure 1.7**).



**Figure 1.7** One of the industrial parks found in Ethiopia.

**The chemical industries** comprise the companies that manufacture inorganic- and organic-industrial chemicals, explosives, fragrances, agrochemicals, polymers and rubber, ceramic products, petrochemicals, oleochemicals (oils, fats, and waxes), and flavors. Central to the world economy, it converts natural resources (oil, natural gas, air, water, metals, and minerals) into diverse products. They are further categorized



into industrial inorganic chemicals; plastics, materials, and synthetics; drugs; soap, cleaners, and toilet goods; paints and allied products; industrial organic chemicals; agricultural chemicals; and miscellaneous chemical products.

**The chemical products** mean products manufactured, processed, sold, or distributed by the company that are chemical substances, or that contained chemical substances. Three general classes of products are (1) basic chemicals such as alkalis, acids, organic chemicals, and salts (2) chemical products to be used in further manufactures such as plastic materials, synthetic fibers, pigments, and dry colors, and (3) finished chemical products to be used for ultimate consumption such as cosmetics, drugs, and soaps; or to be used as materials or supplies in other industries such as fertilizers, paints, and explosives.

Currently, there are more than 51 medium and large-scale chemical and chemical products industries (enterprises) in Ethiopia (**Table 1.1**). These enterprises produce chemicals like aluminum sulphate, caustic soda, soda ash, carbon dioxide, bleaching chemicals, magnesium oxide, pesticides, and chemical products like soap and detergent, cement, paints, building materials, cosmetics, plastic, natural gum, candle, glass, sugar, tyre, pulp and paper, pharmaceuticals and tobacco.

**Table 1.1** Some of the large and medium scale chemical enterprises in Ethiopia.

No	Name of the Enterprise	Region	Zone	Wereda/ Sub-city	City
1	Chorra Gas & Chemical	A.A		N.S.L	A.A
2	Awash Melkasa Aluminum Sulphate	Oromia	East Shoa	Adama	Awash Melkasa
3	Zeway Caustic Soda	Oromia	East Shoa	Adamitulu	Zeway
4	Abijata Soda Ash Factory	Oromia	East Shoa	Adamitulu	Bulbula
5	Moha Soft Drinks CO <sub>2</sub> Factory	A.A		Kirkos	A.A
6	Adola Magnesium Oxide Factory	Oromia	Guji	Adolawoy	Adolarede
7	Adami-Tulu Pesticide Factory	Oromia	East Shoa	Jido Combolcha	Adami-Tulu
8	Nefas Silk Paints	A.A		Kirkos	A.A
9	Zemenawi Building Industries	Oromia	East Shoa	Dukem	Dukem
10	Kadisco Chemical Industry	A.A		Akaki Kaliti	A.A
11	Mesfin Tadesse Soap Factory	Oromia	Woliso		Woliso
12	Etab Laundry Soap Factory	Sidama		Hawassa	Hawassa
13	Get Eshet Detergent	Oromia	Adea Liben		Bishoftu

## Chemistry Grade 9

No	Name of the Enterprise	Region	Zone	Wereda/ Sub-city	City
14	Natural Gum Marketing Enterprise	Amhara	Awi		Awi
15	Y.B Cosmetics	A.A		Burayu	A.A
16	Mekabe PLC (Cosmetics)	A.A		Lideta	A.A
17	Fanos Detergent Factory P.L.C	Tigray	Central	Axum	Axum
18	Petera Soap Factory	Oromia	S.W. Shoa	Alemgena	Sebeta
19	Teamco Hi-jaxs Soap Factory	Oromia	Burayu Liyu	Burayu	Burayu

**Note:** A.A stands for Addis Ababa; S.W stands for South West.

Other chemical product industries in Ethiopia.

- ☞ Cement (Mugher, Diredawa, Mesobo, Derba, Midroc, Dangote)
- ☞ Sugar (Metehara, Wonji, Finchaa, Omokuraz)
- ☞ Paper and pulp (Wonji)
- ☞ Pharmaceuticals (Addis, Ethiopia, Adigrat) (**Figure 1.10**)
- ☞ Tyre (Horizon Addis Tyre)



### Exercise 1.5

Provide the correct answer for the following questions.

1. List the common names together with the chemical names, formula, and use of 10 household chemicals.
2. Browse the Internet or use other sources and find out 10 other household chemicals that are commonly used in different homes with their corresponding molecular formula, chemical names, and use.
3. List at least 15 chemical industries that are found in Ethiopia.

### Project work 1.1

#### An industrial trip to the local industries

In this project, you will be able to visit a local chemical industry and present your observations to the class in group.

Students, your teacher will arrange an industrial tour so that you will practically observe the raw materials, the chemical processes involved, and the finished products in the industries that are located in your vicinity. You are required to write a report and present it to the class in group.

## Key Terms of the Unit

☞ Analgesics	☞ Composition	☞ Metallurgy
☞ Antibiotics	☞ Disinfectants	☞ Property
☞ Anesthetics	☞ Energy	☞ Structure
☞ Antiseptics	☞ Industry	☞ Substance
☞ Chemistry	☞ Insecticides	☞ Tranquilizers
☞ Chemical products	☞ Matter	
☞ Chemical industry		

## Unit Summary

Chemistry is the science that deals with the properties, compositions, and structures of substances, the transformations they undergo, and the energy that is released or absorbed during these processes.

The study of modern chemistry has many branches, but can generally be broken down into five main disciplines, or areas of study: Organic chemistry, Inorganic chemistry, Physical chemistry, Analytic chemistry and Biochemistry. The scope of chemistry includes production and processing of food; improving health and sanitation facilities; environmental protection; provision of comfort, pleasure and luxury; advancement and growth of industry; and weapon production. Because living and non-living things are made up of matter, chemistry affects all aspects of life, and most natural events. The scope of chemistry can also be extended to explaining the natural world, preparing people for career opportunities, and producing informed patriot citizens.

Chemistry is the central science in the natural sciences. Being one of the basic sciences Chemistry is related to other natural sciences like Biology, Physics, Geology, Medicine, and Mathematics. Chemistry and Biology are related by the metabolic processes occurring inside living matter known as Biochemistry. Chemistry and Geology are related by the processes that control the abundance, composition, and distribution of chemical compounds and isotopes inside the crust of the earth known as Geochemistry. A sub-discipline of chemistry and physics that investigates physicochemical phenomena using techniques from atomic and molecular physics and condensed matter physics is known as Chemical physics. Chemistry and Medicine are related by a discipline that encloses the design, development, and synthesis of pharmaceutical drugs called Medicinal chemistry. Chemistry and Mathematics are related by the area of research engaged itself principally with the mathematical modelling of chemical phenomena called Mathematical chemistry.

Since Chemistry is so fundamental to our world, it plays a role in everyone's lives and touches almost every aspect of our existence in some way. Chemistry is essential for meeting our basic needs such as food, clothing, shelter, health, energy, and clean air, water, and soil. Chemistry can also help us comprehend, monitor, protect and recover the environment around us. Chemistry plays an important role in shaping the current state, and the predictions of the future state of the earth's environment

## Chemistry Grade 9

as a large number of agents that force the earth's climate are chemically active. Chemistry, however, can also affect our environment negatively through production of toxic substances. The release of these toxic substances into the environment results in climate change, the prime issue the world is facing currently. It is, therefore, high time to seek for solution to this problem by using our chemical knowledge.

Chemistry plays a significant role in the advancement and growth of several industries. There are several chemical and chemical products industries that produce a number of chemicals and chemical products. One way of categorizing them is into industrial inorganic chemicals; plastics, materials, and synthetics; drugs; soap, cleaners, and toilet goods; paints and allied products; industrial organic chemicals; agricultural chemicals; and miscellaneous chemical products.

The Ethiopian government is working hard in establishing Industrial Zones throughout the nation. Currently, there are more than 51 medium and large-scale chemical and chemical products industries (enterprises) in Ethiopia. These enterprises produce chemicals like aluminum sulphate, caustic soda, soda ash, carbon dioxide, bleaching chemicals, magnesium oxide, pesticides; and chemical products like soap and detergent, cement, paints, building materials, cosmetics, plastic, natural gum, candle, glass, sugar, tyre, pulp and paper, pharmaceuticals and tobacco.

### Review Exercise

#### Part I: Basic level questions.

Identify each of the following statements as 'True' or 'False'. Give your reason(s) for false statements.

1. Chemistry is a science that deals with the study of the way living things behave.
2. Every substance in the universe, in which we live, has its own properties by which we can distinguish it from other substances.
3. The transformation of a substance is a marked change in form, nature, or appearance.
4. The study of chemistry involves only microscopic information.
5. Organic chemistry is the study of chemicals that are not based on carbon.

#### Part II: Intermediary level questions.

6. The property of a substance is its \_\_\_\_\_, \_\_\_\_\_ or \_\_\_\_\_.
7. \_\_\_\_\_ is the nature of something's ingredients or constituents; the way in which a whole or mixture is made up.
8. The arrangement of and relations between the parts or elements of something complex is known as its \_\_\_\_\_.
9. \_\_\_\_\_ is a power derived from the utilization of physical or chemical resources, especially to provide light and heat.
10. \_\_\_\_\_ is the study of macroscopic properties, atomic properties, and phenomena in chemical systems.

11. \_\_\_\_\_ is the study of the composition of matter.

### **Part III: Challenge level questions.**

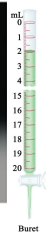
12. Define the terms industry, chemical industry, and chemical products.
13. What are the roles chemistry played in production and society?
14. How does chemistry play a role in increasing comfort, pleasure, and luxuries?
15. Mention at least 10 chemical industries found in Ethiopia and their chemical products.
16. Which branch of chemistry has the highest scope? Why?
17. What are the five fields of chemistry?
18. What will be the future efforts of chemistry?
19. What jobs can you do with chemistry?



# UNIT 2



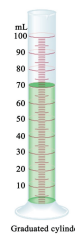
Triple-beam balance



Buret



Pipet



Graduated cylinder



Volumetric flask

## MEASUREMENTS AND SCIENTIFIC METHODS

### Unit Outcomes

After completing the unit, you will be able to

- ☞ use proper SI units;
- ☞ identify the causes of uncertainty in measurement;
- ☞ express the result of any calculation involving experimental data to the appropriate number of decimal places or significant figures;
- ☞ apply scientific methods in solving problems;
- ☞ demonstrate an understanding of experimental skills in chemistry;
- ☞ demonstrate a knowledge of basic laboratory apparatuses and safety rules;
- ☞ describe scientific inquiry skills along this unit: observing, inferring, predicting, comparing & contrasting, communicating, analyzing, classifying, applying, theorizing, measuring, asking question, developing hypothesis, designing experiment, interpreting data, drawing conclusion, making generalizations and problem solving.



## 2.1 Measurements and Units in Chemistry

### Learning competencies

At the end of this section, you should be able to

- ☞ list the seven SI units and their prefixes;
- ☞ describe the seven SI units and their prefixes;
- ☞ write the names and symbols of derived SI units;
- ☞ use the factor label method for solving problems and making conversion of SI units;
- ☞ describe uncertainty of measurement;
- ☞ identify the digits that are certain and the ones that are uncertain given a number representing measurement;
- ☞ identify causes of uncertainty in measurement;
- ☞ define precision and accuracy;
- ☞ estimate the precision possible for any instrument they use in the laboratory;
- ☞ explain systematic and random errors;
- ☞ analyze given data in terms of precision and accuracy;
- ☞ define significant figures;
- ☞ determine the number of significant figures in a calculated result;
- ☞ use the scientific notation in writing very large or very small numbers.



#### Start-up Activity

Conduct the following activity and present your finding to the class.

1. In group, discuss and list down different traditional ways of measuring mass of solid and liquid substances sold in the market places in your area.
2. Mention indigenous methods of measurements (length, mass, time, volume)

Measurement is the comparison of a physical quantity to be measured with a unit of measurement that is, with a fixed standard of measurement. On a centimeter scale, the centimeter unit is the standard of comparison. In traditional markets people buy and sell goods by estimating their size in traditional way or use traditional measurement method. **Figure 2.1** shows traditional market and people exchanging goods by estimating their size using indigenous methods of measurements.

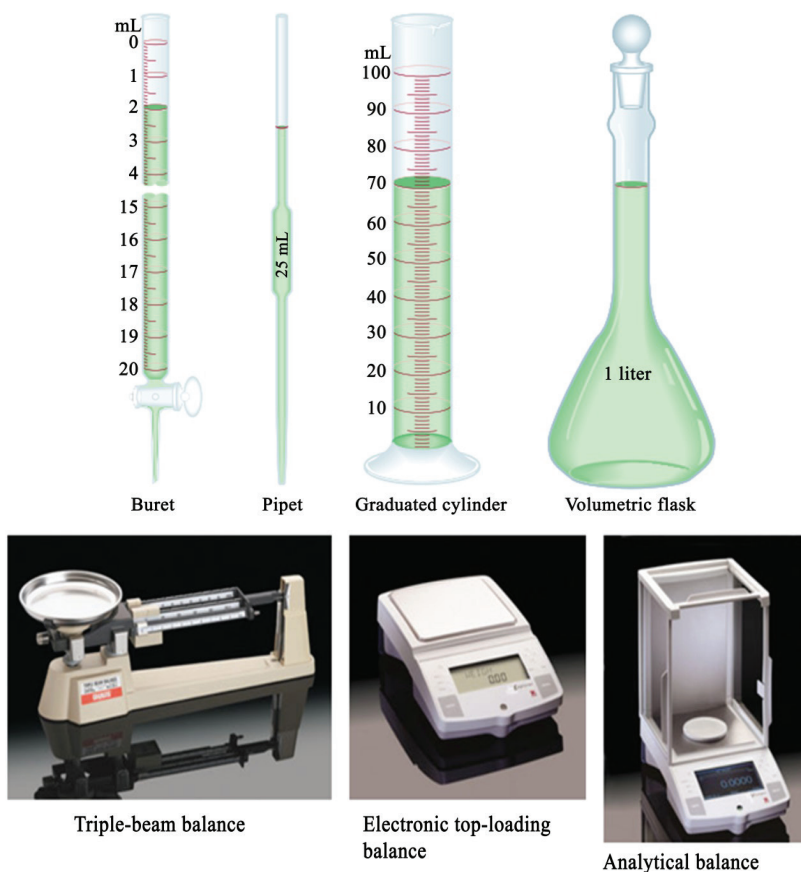




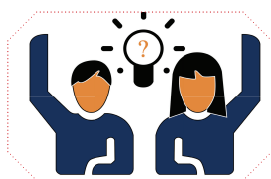
**Figure 2.1** Traditional market.

The study of chemistry depends heavily on measurement. For instance, chemists use measurements to compare the properties of different substances and to assess changes resulting from an experiment. A number of common devices enable us to make simple measurements of a substance's properties: The meter stick measures length; the burette, the pipette, the graduated cylinder, and the volumetric flask measure volume (see **Figure 2.2**); the balance measures mass; the thermometer measures temperature.

The instruments illustrated on **Figure 2.2** provide measurements of macroscopic properties, which can be determined directly. Microscopic properties, on the atomic or molecular scale, must be determined by an indirect method. A measured quantity is usually written as a number with an appropriate unit. To say the distance between Addis Ababa and Hawassa by car along a certain route is 275 is meaningless. We must specify that the distance is 275 kilometers. In science, units are essential to state measurements correctly.



**Figure 2.2** Some common measuring devices found in a chemistry laboratory.



**Activity 2.1**

Conduct the following activity and present your finding to the class.

- a. Using thermometer with °C and °F scale measure your body temperature. Compare the results in °C with the result in °F.
- b. What is the distance between Addis Ababa and your town (village) in kilometers?
- c. Which basic SI units are appropriate to express the:
  - i. average room temperature, and
  - ii. time duration for the earth to have one rotation around its axis?

**2.1.1 SI Units (The International System of Units)**

For many years, scientists recorded measurements in metric units, which are related decimally, that is, by powers of 10. In 1960, however, the General Conference of Weights and Measures, the international authority on units, proposed a revised metric

system called the International System of Units.

**Table 2.1** shows the seven SI base units. Measurements that we will utilize frequently in our study of chemistry include time, mass, volume, density, and temperature.

**Table 2.1** SI Base Units.

Base Quantity	Name of Unit	Symbol
Length	Meter	m
Mass	Kilogram	kg
Time	Second	s
Electrical current	Ampere	A
Temperature	Kelvin	K
Amount of substance	Mole	mol
Luminous intensity	Candela	cd

### 2.1.2 Derived Units

All other SI units of measurement can be derived from base units (called derived units). **Table 2.2** shows some of the common derived units. Once base units have been defined for a system of measurement, you can derive other units from them. You do this by using the base units in equations that define other physical quantities. For example, area is defined as length times width. Therefore,

$$\text{SI unit of area} = (\text{SI unit of length}) \times (\text{SI unit of width})$$

From this, SI unit of area is meter  $\times$  meter, or  $\text{m}^2$ . Similarly, speed is defined as the rate of change of distance with time; that is, speed = distance/time. Consequently,

$$\text{SI unit of speed} = \frac{\text{SI unit of distance}}{\text{SI unit of time}}$$

The SI unit of speed is meters per second (that is, meters divided by seconds). The unit is symbolized  $\text{m/s}$  or  $\text{m s}^{-1}$ . The unit of speed is an example of an SI derived unit, which is a unit derived by combining SI base units. **Table 2.2** displays a number of derived units. Volume and density are discussed in this section.

### Volume

Volume is defined as length cubed and has the SI unit of cubic meter ( $\text{m}^3$ ). This is too large a unit for normal laboratory work, so we use either cubic decimeters ( $\text{dm}^3$ ) or cubic centimeters ( $\text{cm}^3$ , also written cc). Traditionally, chemists have used the liter (L), which is a unit of volume equal to a cubic decimeter. In fact, most laboratory glassware (**Figure 2.2**) is calibrated in liters or milliliters ( $1000 \text{ mL} = 1 \text{ L}$ ). Because 1 dm equals 10 cm, a cubic decimeter, or one liter, equals  $(10 \text{ cm})^3 = 1000 \text{ cm}^3$ . Therefore, a milliliter equals a cubic centimeter. In summary,

$$1 \text{ L} = 1 \text{ dm}^3 \text{ and } 1 \text{ mL} = 1 \text{ cm}^3.$$

**Table 2.2** Derived units.

Quantity	Definition of Quantity	SI Unit
Area	Length squared	m <sup>2</sup>
Volume	Length cubed	m <sup>3</sup>
Density	Mass per unit volume	kg/m <sup>3</sup>
Speed	Distance traveled per unit time	m/s
Acceleration	Speed changed per unit time	m/s <sup>2</sup>
Force	Mass times acceleration of object	kg.m/s <sup>2</sup> (= newton, N)
Pressure	Force per unit area	kg/(m.s <sup>2</sup> )(= pascal, Pa)
Energy	Force times distance traveled	kg.m <sup>2</sup> /s <sup>2</sup> (= joule, J)

**Density**

The density of an object is its mass per unit volume. You can express this as

$$d = \frac{m}{v}$$

where  $d$  is the density,  $m$  is the mass, and  $V$  is the volume. Suppose an object has a mass of 15.0 g and a volume of 10.0 cm<sup>3</sup>. Therefore, the density will be

$$d = \frac{15.0 \text{ g}}{10.0 \text{ cm}^3} = 1.50 \text{ g/cm}^3$$

The density of the object is 1.50 g/cm<sup>3</sup>.

Density is an important characteristic property of a material. Water, for example, has a density of 1.000 g/cm<sup>3</sup> at 4 °C and a density of 0.998 g/cm<sup>3</sup> at 20 °C. Lead has a density of 11.3 g/cm<sup>3</sup> at 20 °C.

Density can also be useful in determining whether a substance is pure. Consider a gold bar whose purity is questioned. The metals likely to be mixed with gold, such as silver or copper, have lower densities than gold. Therefore, an adulterated (impure) gold bar can be expected to be far less dense than pure gold.

**Example 2.1:** Calculating the density of a substance

A colorless liquid, used as a solvent (a liquid that dissolve other substances), is believed to be one of the following (**Table 2.3**):

**Table 2.3** Density of different liquids.

Substance	Density (in g/mL)
n-butyl alcohol	0.810
ethylene glycol	1.114
isopropyl alcohol	0.785
toluene	0.866

To identify the substance, Chaltu determined its density. By pouring a sample of the liquid into a graduated cylinder, she found that the volume was 35.1 mL. She also found that the sample weighed 30.5 g. What was the density of the liquid? What was the substance?

### Solution

The solution to this problem lies in finding the density of the unknown substance. Once the density of the unknown substance is known, you can compare it to the list of known substances presented in the problem and look for a match. Density is the relationship of the mass of a substance per volume of that substance. Expressed as an equation, density is the mass divided by the volume:  $d = m/V$ .

You substitute 30.5 g for the mass and 35.1 mL for the volume into the equation.

$$d = \frac{m}{v} = \frac{30.5 \text{ g}}{35.1 \text{ mL}} = 0.869 \text{ g/mL}$$

The density of the liquid equals that of toluene (within experimental error).

**Answer Check** Always be sure to report the density in the units used when performing the calculation. Density is not always reported in units of g/mL or  $\text{g/cm}^3$ , for example; gases are often reported with the units of g/L.



### Exercise 2.1

A piece of metal wire has a volume of  $20.2 \text{ cm}^3$  and a mass of 159 g. What is the density of the metal? We know that the metal is manganese, iron, or nickel, and these have densities of  $7.21 \text{ g/cm}^3$ ,  $7.87 \text{ g/cm}^3$ , and  $8.90 \text{ g/cm}^3$ , respectively. From which metal is the wire made?

### Heat and Temperature

Temperature measures the intensity of heat, the “hotness” or “coldness” of a body. Heat is a form of energy that always flows spontaneously from a hotter body to a colder body — never in the reverse direction.

Relationships among the three temperature scales are illustrated in **Figure 2.4**. Between the freezing point of water and the boiling point of water, there are 100 steps ( $^{\circ}\text{C}$  or Kelvins, respectively) on the Celsius and Kelvin scales. Thus, the “degree” is the same size on the Celsius and Kelvin scales. But every Kelvin temperature is 273.15 units above the corresponding Celsius temperature. The relationship between these two scales is as follows:

$$K = ^{\circ}\text{C} + 273.15 \text{ } ^{\circ}\text{C} \text{ or } ^{\circ}\text{C} = K - 273.15^{\circ}$$

## Chemistry Grade 9

In the SI system, “degrees Kelvin” are abbreviated simply as K rather than °K and are called *kelvins*.

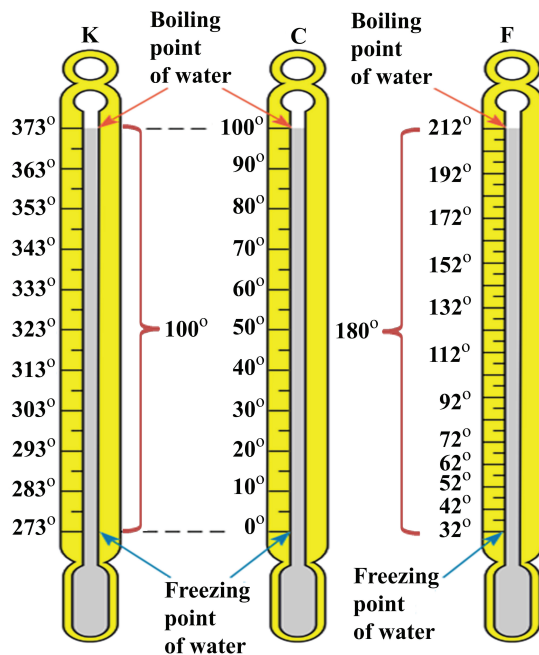
Any temperature change has the same numerical value whether expressed on the Celsius scale or on the Kelvin scale. For example, a change from 25°C to 59°C represents a change of 34 Celsius degrees. Converting these to the Kelvin scale, the same change is expressed as (273 + 25) = 298 K to (59 + 273) = 332 K, or a change of 34 kelvins.

Comparing the Fahrenheit and Celsius scales, we find that the intervals between the same reference points are 180 Fahrenheit degrees and 100 Celsius degrees, respectively. Thus, a Fahrenheit degree must be smaller than a Celsius degree. It takes 180 Fahrenheit degrees to cover the same temperature interval as 100 Celsius degrees. From this information, we can construct the unit factors for temperature changes:

$$\frac{180\text{ }^{\circ}\text{F}}{100\text{ }^{\circ}\text{C}} \text{ or } \frac{1.8\text{ }^{\circ}\text{C}}{1.0\text{ }^{\circ}\text{F}} \text{ and } \frac{100\text{ }^{\circ}\text{C}}{180\text{ }^{\circ}\text{F}} \text{ or } \frac{1.0\text{ }^{\circ}\text{C}}{1.8\text{ }^{\circ}\text{F}}$$

But the starting points of the two scales are different, so we cannot convert a temperature on one scale to a temperature on the other just by multiplying by the unit factor. In converting from °F to °C, we must subtract 32 Fahrenheit degrees to reach the zero point on the Celsius scale (**Figure 2.3**).

$$^{\circ}\text{F} = \left( x^{\circ}\text{C} \times \frac{1.8^{\circ}\text{F}}{1.0^{\circ}\text{C}} \right) + 32^{\circ}\text{F} = \left( x^{\circ}\text{C} \times \frac{9^{\circ}\text{F}}{5^{\circ}\text{C}} \right) + 32^{\circ}\text{F} \text{ and } ^{\circ}\text{C} = \frac{1.0^{\circ}\text{C}}{1.8^{\circ}\text{F}} (x^{\circ}\text{F} - 32^{\circ}\text{F}) = \frac{5^{\circ}\text{C}}{9^{\circ}\text{F}} (x^{\circ}\text{F} - 32^{\circ}\text{F})$$



**Figure 2.3** The relationships among the Kelvin, Celsius (centigrade), and Fahrenheit temperature scales.

**Example 2.2:** Temperature conversion

When the temperature reaches “100.°F in the shade,” it’s hot. What is this temperature on the Celsius scale?

**Solution**

We use the relationship  $^{\circ}C = \frac{1.0^{\circ}C}{1.8^{\circ}F} (x^{\circ}F - 32^{\circ}F)$

to carry out the desired conversion.  $^{\circ}C = \frac{1.0^{\circ}C}{1.8^{\circ}F} (100^{\circ}F - 32^{\circ}F) = \frac{1.0^{\circ}C}{1.8^{\circ}F} (68^{\circ}F) = 38^{\circ}C$

**Exercise 2.2**

## Temperature Conversion

When the absolute temperature is 400 K, what is the Fahrenheit temperature?

**2.1.3 Common Prefixes Used in SI Units**

The factor expressed as a factor to the power of ten, SI/ metric prefix, the symbol used and the actual decimal number are tabulated in **Table 2.4**. They are widely used and are easy to add to the basic units. Like metric units, SI units are modified in decimal fashion by a series of prefixes, as shown in **Table 2.4**. Measurements that we will utilize frequently in our study of chemistry include time, mass, volume, density, and temperature.

**Table 2.4** SI/ Metric Units, Symbols and Numbers.

Factor	Prefix	Symbol	Decimal	Example
$10^{12}$	Tera	T	1,000,000,000,000	1 Terameter (Tm) = $1 \times 10^{12}$ m
$10^9$	Giga	G	1,000,000,000	1 Gigameter (Gm) = $1 \times 10^9$ m
$10^6$	Mega	M	1,000,000	1 Megameter (Mm) = $1 \times 10^6$ m
$10^3$	Kilo	k	1,000	1 kilometer (km) = $1 \times 10^3$ m
$10^2$	Hecto	h	100	1 hectometer (hm) = $1 \times 10^2$ m
$10^1$	Deca	da	10	1 decameter (dam) = $1 \times 10^1$ m
$10^{-1}$	Deci	d	0.1	1 decimeter (dm) = $1 \times 10^{-1}$ m
$10^{-2}$	Centi	c	0.01	1 centimeter (cm) = $1 \times 10^{-2}$ m
$10^{-3}$	milli-	m	0.001	1 millimeter (mm) = $1 \times 10^{-3}$ m
$10^{-6}$	Micro	$\mu$	0.000 001	1 micrometer ( $\mu$ m) = $1 \times 10^{-6}$ m
$10^{-9}$	Nano	n	0.000 000 001	1 nanometer (nm) = $1 \times 10^{-9}$ m
$10^{-12}$	Pico	p	0.000 000 000 001	1 picometer (pm) = $1 \times 10^{-12}$ m

### Examples of SI prefixes

The SI prefixes/ metric prefixes are easily used as demonstrated by the few simple examples given below:

- ☞ 1 Megawatt = 1,000,000 watts
- ☞ 1 kilogram = 1,000 grams
- ☞ 1  $\mu\text{F}$  = 1 microFarad = 1/1,000,000 Farad

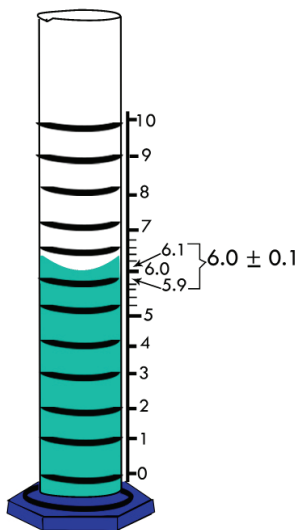
Along with these the abbreviations or symbols can also be used. For example, kV for kilovolts, kW for kilowatts, and km for kilometer. The other symbols or abbreviations can be used in exactly the same manner.

### 2.1.4 Uncertainty in Measurements

Whenever you measure something, there is always some uncertainty. There are two categories of uncertainty: systematic and random.

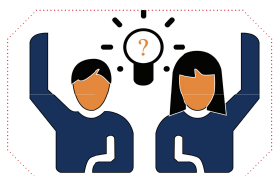
1. Systematic uncertainties are those which consistently cause the value to be too large or too small. Systematic uncertainties include such things as reaction time, inaccurate meter sticks, optical parallax and miscalibrated balances. In principle, systematic uncertainties can be eliminated if you know they exist.
2. Random uncertainties are variations in the measurements that occur without a predictable pattern. If you make precise measurements, these uncertainties arise from the estimated part of the measurement. Random uncertainty can be reduced, but never eliminated. We need a technique to report the contribution.

The uncertainty shall rather be understood as an interval within which the result can be found with a given probability. Thus, the result will be within the interval but all values within the interval have the same probability to represent the result.



**Figure 2.4** Uncertainty in volume measurement using a measuring cylinder.





### Activity 2.2

Conduct the following activity and present your finding to the class.

1. Make a chain of paper clips or other objects of uniform length. Then use a meter stick to measure a series of lengths on the chain. For example, measure sections containing one, two, three, etc., clips. Record your results and share them with your classmates.
2. Using laboratory scale, take several mass reading for one, two, three objects of uniform size. You can use any convenient objects you find in the laboratory. Record your results and discuss them in your group. Focus especially on the similarities and differences in your measurement. Did you all find the same reading for the same object? What do you think are the cause of the uncertainties, if any? Discuss the results with the rest of the class.

### Calculating uncertainties

There are several techniques that will produce an estimate of the uncertainty in the value of the mean. Since we are expecting students to produce an estimate of the uncertainty any suitable value that indicates half the range is acceptable.

**Example 2.3:** A student measures the diameter of a metal canister using a ruler graduated in mm and records these results:

Diameter/mm			
Reading 1	Reading 2	Reading 3	Mean
66	65	61	64

The uncertainty in the mean value (64 mm) can be calculated as follows:

a. Using the half range

The range of readings is 61 mm – 66 mm so half the range is used to determine the uncertainty.

$$\text{Uncertainty in the mean diameter} = (66 \text{ mm} - 61 \text{ mm})/2 = 2.5 \text{ mm}$$

Therefore, the diameter of the metal canister is 64 mm  $\pm$  2.5 mm.

Since a ruler graduated in mm could easily be read to  $\pm$  0.5 mm, it is acceptable to quote the uncertainty as  $\pm$  2.5 mm for this experiment.

b. Using the reading furthest from the mean

In this case, the measurement of 61 mm is further from the average value than 66 mm therefore we can use this value to calculate the uncertainty in the mean.

$$\text{Uncertainty in the mean diameter} = 64 \text{ mm} - 61 \text{ mm} = 3 \text{ mm.}$$

Therefore, the diameter of the metal canister is 64 mm  $\pm$  3 mm.

## Chemistry Grade 9

### c. Using the resolution of the instrument

This is used if a single reading is taken or if repeated readings have the same value. This is because there is an uncertainty in the measurement because the instrument used to take the measurement has its own limitations. If the three readings obtained above were all 64 mm then the value of the diameter being measured lies somewhere between 63.5 mm and 64.5 mm since a meter rule could easily be read to half a millimeter. In this case, the uncertainty in the diameter is 0.5 mm. Therefore, the diameter of the metal canister is  $64 \text{ mm} \pm 0.5 \text{ mm}$ . This also applies to digital instruments. An ammeter records currents to 0.1 A. A current of 0.36 A would be displayed as 0.4 A, and a current of 0.44 A would also be displayed as 0.4 A. The resolution of the instrument is 0.1 A but the uncertainty in a reading is 0.05 A.

The typical uncertainty of a top loading balance is 0.05 g. How would you report on weighing of 23.25 g made on this top loading balance? The result should be reported as  $23.25 \text{ g} \pm 0.05 \text{ g}$ . Such an item of data means that the correct reading lies between 23.20 g and 23.30 g.

The uncertainty in a measurement can be expressed in two useful ways:

- as the absolute uncertainty in the last digit written
- as the percent uncertainty calculated as follows

$$\% \text{ uncertainty} = \frac{\text{absolute uncertainty}}{\text{measurement}} \times 100$$

$$\% \text{ uncertainty} = (0.05 \text{ g}) / (23.25 \text{ g}) \times 100 = 0.2\%$$

Therefore the answer may be reported as:

Absolute uncertainty:  $23.25 \text{ g} \pm 0.05 \text{ g}$

Percent uncertainty:  $23.25 \text{ g} \pm 0.2\%$



### Exercise 2.3

**Absolute uncertainty and percent uncertainty in a single reading:** Use the given uncertainty to calculate the % uncertainty in each of the following readings and report the result of measurement in terms of absolute uncertainty and percent uncertainty:

- A barometer reading of 723.5 torr. The absolute uncertainty is 0.1 torr
- 2.75 g weighed on a top loading balance. The absolute uncertainty is 0.05 g
- 2.7413 g weighed on an analytical balance. The absolute uncertainty is 0.0002 g

- d. A temperature reading of  $75.6\text{ }^{\circ}\text{C}$  on a thermometer graduated to the nearest degree. The absolute uncertainty is  $0.2\text{ }^{\circ}\text{C}$
- e.  $18.6\text{ ml}$  measured in  $100\text{ ml}$  graduated cylinder. The absolute uncertainty is  $0.4\text{ mL}$
- f.  $43.7\text{ ml}$  measured in  $100\text{ ml}$  graduated cylinder. The absolute uncertainty is  $0.4\text{ mL}$

### 2.1.5 Precision and Accuracy

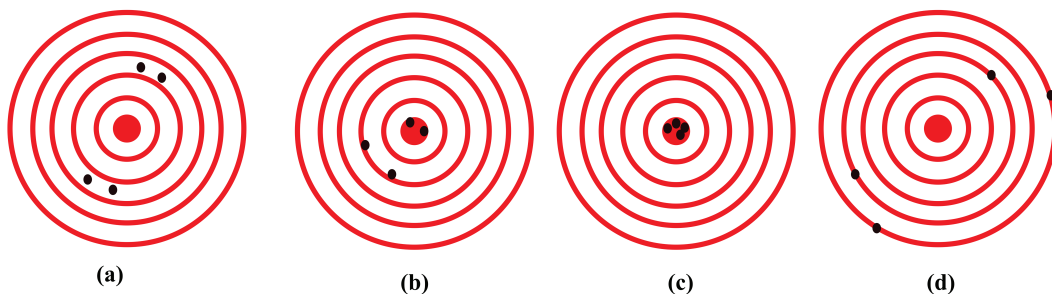
Measurements may be accurate, meaning that the measured value is the same as the true value; they may be precise, meaning that multiple measurements give nearly identical values (i.e., reproducible results); they may be both accurate and precise; or they may be neither accurate nor precise. The goal of scientists is to obtain measured values that are both accurate and precise.

If you repeat a particular measurement, you usually do not obtain precisely the same result, because each measurement is subject to experimental error. The measured values vary slightly from one another. Suppose you perform a series of identical measurements of a quantity. The term precision refers to the closeness of the set of values obtained from identical measurements of a quantity. Accuracy is a related term; it refers to the closeness of a single measurement to its true value.

#### Example 2.4: Precision and Accuracy

The archery targets in **Figure 2.5** show marks that represent the results of four sets of measurements. Which target shows;

- a. a precise but inaccurate set of measurements?
- b. an accurate but imprecise set of measurements?
- c. a set of measurements that is both precise and accurate?
- d. a set of measurements that is neither precise nor accurate?



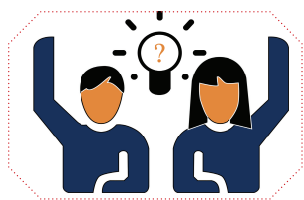
**Figure 2.5** The distribution of darts on a dart board showing the difference between precise and accurate.

Form groups, discuss and present your conclusion to the class

1. Mohammed measured the mass of a sample of gold using one balance and found 1.896 g. On a different balance, the same sample was found to have a mass of 1.125 g. Which measurement was correct the first or the second measurement? Careful and repeated measurements made by Mohammed, including measurements on a calibrated third balance, showed the sample to have a mass of 1.895 g. The masses obtained from the three balances are in the **Table 2.5**:

**Table 2.5** Mass measurement

Balance 1	Balance 2	Balance 3
1.896 g	1.125 g	1.893 g
1.895 g	1.158 g	1.895 g
1.894 g	1.067 g	1.895 g



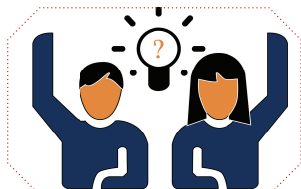
### Activity 2.3



### Exercise 2.4

- a. A 2-carat diamond has a mass of 400.0 mg. When a jeweler repeatedly weighed a 2-carat diamond, he obtained measurements of 450.0 mg, 459.0 mg, and 463.0 mg. Were the jeweler's measurements accurate? Were they precise?
- b. A single copper penny was tested three times to determine its composition. The first analysis gave a composition of 93.2% zinc and 2.8% copper, the second gave 92.9% zinc and 3.1% copper, and the third gave 93.5% zinc and 2.5% copper. The actual composition of the penny was 97.6% zinc and 2.4% copper. Were the results accurate? Were they precise?

## 2.1.6 Significant Figures

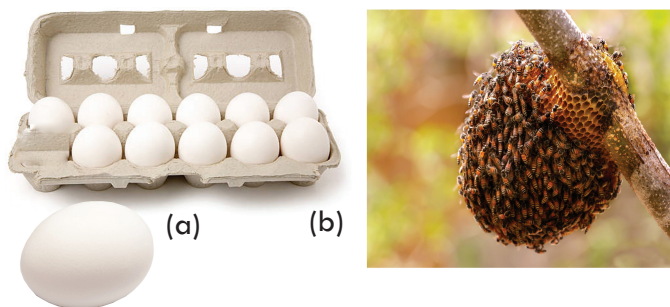


### Activity 2.4

Exact and measured numbers: Classify the following as exact or measured numbers and give explanation for your classification to the rest of the class.

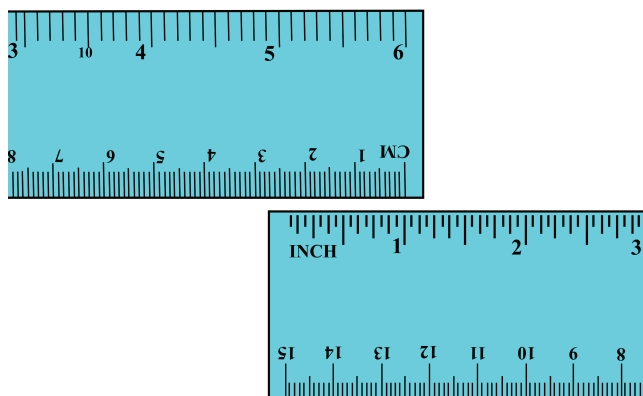
- The distance between your home and school
- Number of oranges in a sack
- Number of aspirin tablet in a strip.
- The volume of a glass of water.

There are two kinds of numbers. Numbers obtained by counting or from definitions are exact numbers. They are known to be absolutely accurate. For example, the exact number of people in a closed room can be counted, and there is no doubt about the number of people. A dozen eggs is defined as exactly 12 eggs, no more, no fewer (**Figure 2.6**).



**Figure 2.6** (a) A dozen eggs is exactly 12 eggs. (b) A specific swarm of honeybees contains an exact number of live bees (but it would be difficult to count them, and any two swarms would be unlikely to contain the same exact number of bees).

Numbers obtained from measurements are not exact. Every measurement involves an estimate. For example, suppose you are asked to measure the length of this page to the nearest 0.1 mm. How do you do it? The smallest divisions (calibration lines) on a meter stick are 1 mm apart (see **Figure 2.7**). An attempt to measure to 0.1 mm requires estimation. If three different people measure the length of the page to 0.1 mm, will they get the same answer? Probably not. We deal with this problem by using significant figures.



**Figure 2.7** The relationship between inches and centimeters: 1 in. = 2.54 cm (exactly)

Except when all the numbers involved are integers (for example, in counting the number of students in a class), obtaining the exact value of the quantity under investigation is often impossible. For this reason, it is important to indicate the margin of error in a measurement by clearly indicating the number of significant figures, which are the meaningful digits in a measured or calculated quantity. When significant figures are used, the last digit is understood to be uncertain. For example, we might measure the volume of a given amount of liquid using a graduated cylinder with a scale that gives an uncertainty of 1 mL in the measurement. If the volume is found to be 6 mL, then the actual volume is in the range of 5 mL to 7 mL. We represent the volume of the liquid as  $(6 \pm 1)$  mL. In this case, there is only one significant figure (the digit 6) that is uncertain by either plus or minus 1 mL. For greater accuracy, we might use a graduated cylinder that has finer divisions, so that the volume we measure is now uncertain by only 0.1 mL. If the volume of the liquid is now found to be 6.0 mL, we may express the quantity as  $(6.0 \pm 0.1)$  mL, and the actual value is somewhere between 5.9 mL and 6.1 mL. We can further improve the measuring device and obtain more significant figures, but in every case, the last digit is always uncertain; the amount of this uncertainty depends on the particular measuring device we use and the user's ability.

**Guidelines for Using Significant Figures:** We must always be careful in scientific work to write the proper number of significant figures. In general, it is fairly easy to determine how many significant figures a number has by using the following rules:

1. Any digit that is not zero is significant. Thus, 845 cm has three significant figures, 1.234 kg has four significant figures, and so on.
2. Zeros between nonzero digits are significant. Thus, 606 m contains three significant figures, 40,501 kg contains five significant figures, and so on.
3. Zeros to the left of the first nonzero digit are not significant. Their purpose is to indicate the placement of the decimal point. For example, 0.08 L contains one significant figure, 0.0000349 g contains three significant figures, and so on.
4. If a number is greater than 1, then all the zeros written to the right of the decimal point count as significant figures. Thus, 2.0 mg has two significant figures, 40.062

mL has five significant figures, and 3.040 dm has four significant figures. If a number is less than 1, then only the zeros that are at the end of the number and the zeros that are between nonzero digits are significant. This means that 0.090 kg has two significant figures, 0.3005 L has four significant figures, 0.00420 min has three significant figures, and so on.

- For numbers that do not contain decimal points, the trailing zeros (that is, zeros after the last nonzero digit) may or may not be significant. Thus, 400 cm may have one significant figure (the digit 4), two significant figures (40), or three significant figures (400). We cannot know which is correct without more information. By using scientific notation, however, we avoid this ambiguity. In this particular case, we can express the number 400 as  $4 \times 10^2$  for one significant figure,  $4.0 \times 10^2$  for two significant figures, or  $4.00 \times 10^2$  for three significant figures.

A second set of rules specifies how to handle significant figures in calculations.

- In addition and subtraction, the answer cannot have more digits to the right of the decimal point than either of the original numbers.

Consider these examples:

$$\begin{array}{r} 89.332 \\ +1.1 \\ \hline 90.432 \end{array} \quad \begin{array}{l} \leftarrow \text{one digit after the decimal point} \\ \leftarrow \text{round off to 90.4} \end{array}$$

$$\begin{array}{r} 2.097 \\ -0.12 \\ \hline 1.977 \end{array} \quad \begin{array}{l} \leftarrow \text{two digits after the decimal point} \\ \leftarrow \text{round off to 1.98} \end{array}$$

The rounding-off procedure is as follows. To round off a number at a certain point we simply drop the digits that follow if the first of them is less than 5. Thus, 8.724 rounds off to 8.72 if we want only two digits after the decimal point. If the first digit following the point of rounding off is equal to or greater than 5, we add 1 to the preceding digit. Thus, 8.727 rounds off to 8.73, and 0.425 rounds off to 0.43.

- In multiplication and division, the number of significant figures in the final product or quotient is determined by the original number that has the smallest number of significant figures. The following examples illustrate this rule:

$$2.8 \times 4.5039 = 12.61092 \quad \rightarrow \quad \text{round off to 13}$$

$$\frac{6.85}{112.04} = 0.0611388789 \quad \rightarrow \quad \text{round off to 0.0611}$$

- Keep in mind that exact numbers obtained from definitions (such as 1 ft, 12 in, where 12 is an exact number) or by counting numbers of objects can be considered to have an infinite number of significant figures.

### Example 2.5 Significant figures

Determine the number of significant figures in the following measurements: (a) 394 cm,

## Chemistry Grade 9

(b) 5.03 g (c) 0.714 m, (d) 0.052 kg, (e)  $2.720 \times 10^{22}$  atoms,  
(f) 3000 mL.

**Solution:** (a) Three, because each digit is a nonzero digit. (b) Three, because zeros between nonzero digits are significant. (c) Three, because zeros to the left of the first non zero digit do not count as significant figures. (d) Two. Same reason as in (c). (e) Four, because the number is greater than one, all the zeros written to the right of the decimal point count as significant figures. (f) This is an ambiguous case. The number of significant figures may be four ( $3.000 \times 10^3$ ), three ( $3.00 \times 10^3$ ), two ( $3.0 \times 10^3$ ), or one ( $3 \times 10^3$ ). This example illustrates why scientific notation must be used to show the proper number of significant figures.



### Exercise 2.5

Significant figures:

Determine the number of significant figures in each of the following measurements:

a. 35 mL

b. 2008 g

c.  $0.0580 \text{ m}^3$

d.  $7.2 \times 10^4$  molecules

e. 830 kg.



### Exercise 2.6

1. Arithmetic operations: Carry out the following arithmetic operations to the correct number of significant figures:

a.  $11,254.1 \text{ g} + 0.1983 \text{ g}$

b.  $66.59 \text{ L} - 3.113 \text{ L}$

c.  $8.16 \text{ m} \times 5.1355$

d.  $0.0154 \text{ kg} \div 88.3 \text{ mL}$

e.  $2.64 \times 10^3 \text{ cm} + 3.27 \times 10^2 \text{ cm}$ .

2. Significant Figures (Addition and Subtraction)

a. Add 37.24 mL and 10.3 mL.

b. Subtract 21.2342 g from 27.87 g.

3. Significant Figures (Multiplication)

What is the area of a rectangle 1.23 cm wide and 12.34 cm long?

## 2.1.7 Scientific Notation and Decimal Places

We use scientific notation when we deal with very large and very small numbers. For example, 197 grams of gold contains approximately 602,000,000,000,000,000,000 gold atoms.

The mass of one gold atom is approximately 0.000 000 000 000 000 000 000 327 gram. In using such large and small numbers, it is inconvenient to write down all the



zeros. In scientific (exponential) notation, we place one nonzero digit to the left of the decimal.

$$602,000,000,000,000,000,000 = 6.02 \times 10^{23}$$

6 places to the left, therefore exponent of 10 is 6

$$0.000\ 000\ 000\ 000\ 000\ 000\ 000\ 327 = 3.27 \times 10^{-22}$$

4 places to the right, therefore exponent of 10 is -4.

The reverse process converts numbers from exponential to decimal form.

### Example 2.6 Unit Conversions

The Ångstrom (Å) is a unit of length,  $1 \times 10^{-10}$  m, that provides a convenient scale on which to express the radii of atoms. Radii of atoms are often expressed in nanometers. The radius of a phosphorus atom is  $1.10$  Å. What is the distance expressed in centimeters and nanometers?

#### Plan

We use the equalities  $1 \text{ Å} = 1 \times 10^{-10} \text{ m}$ ,  $1 \text{ cm} = 1 \times 10^{-2} \text{ m}$ , and  $1 \text{ nm} = 1 \times 10^{-9} \text{ m}$  to construct the unit factors that convert  $1.10 \text{ Å}$  to the desired units.

**Solution:** Let  $x$  be the length in cm unit and  $y$  the length in nm.

$$x \text{ cm} = 1.10 \text{ Å} \times \frac{1 \times 10^{-10} \text{ m}}{1 \text{ Å}} \times \frac{1 \text{ cm}}{1 \times 10^{-2} \text{ m}} = 1.10 \times 10^{-8} \text{ cm}$$

$$y \text{ nm} = 1.10 \text{ Å} \times \frac{1 \times 10^{-10} \text{ m}}{1 \text{ Å}} \times \frac{1 \text{ nm}}{1 \times 10^{-9} \text{ m}} = 1.10 \times 10^{-1} \text{ nm}$$



### Exercise 2.7

#### Volume Calculation

Assuming a phosphorus atom is spherical; calculate its volume in  $\text{Å}^3$ ,  $\text{cm}^3$ , and  $\text{nm}^3$ . The formula for the volume of a sphere is  $V = \frac{4}{3} \pi r^3$ . Refer to Example above.

## 2.2 Chemistry as Experimental Science

### Learning competencies

At the end of this section, you should be able to

- ☞ define scientific method;
- ☞ describe the major steps of the scientific method;
- ☞ use scientific methods in solving problems;

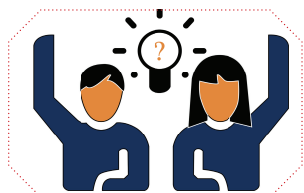
- ☞ demonstrate some experimental skills in chemistry;
- ☞ describe the procedures of writing laboratory report.

Chemistry is largely an experimental science, and a great deal of knowledge comes from laboratory research. In addition, however, today's chemist may use a computer to study the microscopic structure and chemical properties of substances or employ sophisticated electronic equipment to analyze pollutants from auto emissions or toxic substances in a soil. Many frontiers in biology and medicine are currently being explored at the level of atoms and molecules the structural units on which the study of chemistry is based.

Chemists participate in the development of new drugs and in agricultural research. What's more, they are seeking solutions to the problem of environmental pollution along with replacements for energy sources. And most industries, whatever their products, have a basis in chemistry. For example, chemists developed polymers (very large molecules) that manufacturers use to make a wide variety of goods, including clothing, cooking utensils, artificial organs, and toys.

Chemistry is evidence based. All chemical statements are based on experiment. Chemistry is part of the body of modern science. It shares the experimental method of all sciences. It improves in time also using new discoveries and concepts from other sciences. In turn, it provides both theoretical and experimental tools to different sciences. Biology and Geology cannot be studied without a thorough understanding of chemical phenomena. Indeed, because of its diverse applications, chemistry is often called the "central science."

### 2.2.1 The Scientific Method



#### Activity 2.5

Conduct the following activity and present your finding to the class.

- Collect a plastic bag filled with different items provided by your teacher.
- Decide on the question you would like to answer about your bag. Write it down. (Do not open the bag)
- Guess what the answer to your question might be. Write down. (Do not open the bag)
- Open your bag and answer the questions.
- Be sure to count the total number of items.

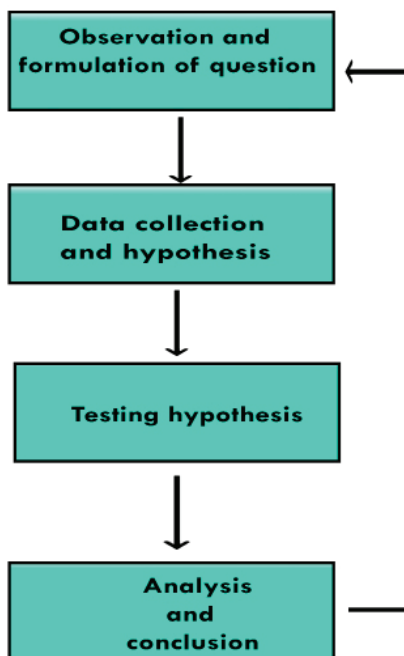
Now, discuss which part of the activity (a, b, c, d, or e) introduces the scientific terminology: hypothesis, data collection, experimentation, etc.

## The Scientific method

What is Scientific Method? The Scientific method is a process with the help of which scientists try to investigate, verify, or construct an accurate and reliable version of any natural phenomena. They are done by creating an objective framework for the purpose of scientific inquiry and analyzing the results scientifically to come to a conclusion which either supports or contradicts the observation made at the beginning.

## Scientific Method Steps

The aim of all scientific methods is the same, that is, to analyze the observation made at the beginning but there are various steps adopted as per the requirement of any given observation. However, there is a generally accepted sequence of steps of scientific methods as it is shown in **Figure 2.8**.



**Figure 2.8** The three main steps of the research process in studying chemistry and their relationships.

- i. **Observation and formulation of a Question:** This is the first step of a scientific method. In order to start one, an observation has to be made into any observable aspect or phenomena of the universe and a question needs to be asked pertaining to that aspect. For example, you can ask, “Why is the sky black at night?” or “Why is air invisible?”
- ii. **Data Collection and Hypothesis:** The next step involved in the scientific method is to collect all related data and formulate a hypothesis based on the observation. The hypothesis could be the cause of the phenomena, its effect, or its relation to any other phenomena.
- iii. **Testing the Hypothesis:** After the hypothesis is made, it needs to be tested scientifically. Scientists do this by conducting experiments. The aim of these

experiments is to determine whether the hypothesis agrees with or contradicts the observations made in the real world. The confidence in the hypothesis increases or decreases based on the result of the experiments.

- iv. **Analysis and Conclusion:** This step involves the use of proper mathematical and other scientific procedures to determine the results of the experiment. Based on the analysis, the future course of action can be determined. If the data found in the analysis is consistent with the hypothesis, it is accepted. If not, then it is rejected or modified and analyzed again.

It must be remembered that a hypothesis cannot be proved or disproved by doing one experiment. It needs to be done repeatedly until there are no discrepancies in the data and the result. When there are no discrepancies and the hypothesis is proved beyond any doubt, it is accepted as a 'theory'.

### 2.2.2 Some Experimental Skills in Chemistry

#### Laboratory Safety Rules

In the home, the kitchen and bathroom are the sites of most accidents. The chemical laboratory poses similar hazards and yet it can be no more dangerous than any other classroom if the following safety rules are always observed. Most of them are based on simple common sense.

1. Responsible behaviour is essential. The dangers of spilled acids and chemicals and broken glassware created by thoughtless actions are too great to be tolerated.
2. Wear approved eye protection at all times in the laboratory and in any area where chemicals are stored or handled. The only exception is when explicit instructions to the contrary are given by your teacher.
3. Perform no unauthorized experiments. This includes using only the quantities instructed, no more. Consult your teacher if you have any doubts about the instructions in the laboratory manual.
4. Do not smoke in the laboratory at any time. Not only is smoking a fire hazard, but smoking draws chemicals in laboratory air (both as vapours and as dust) into the lungs.
5. In case of fire or accident, call the teacher at once. Note the location of fire extinguishers and safety showers now so that you can use them if needed.
6. Report all injuries to your instructor at once. Except for very superficial injuries, you will be required to get medical treatment for cuts, burns, or fume inhalation.
7. Do not eat or drink anything in the laboratory.
8. Avoid breathing fumes of any kind.
9. Never use mouth suction in filling pipets with chemical reagents. Always use a suction device.
10. Never work alone in the laboratory. There must be at least one other person present in the same room. In addition, your teacher should be quickly available.
11. Wear shoes in the laboratory. Bare feet are prohibited because of the danger from broken glass. Sandals are prohibited because of the hazard from chemical

- spills.
12. Confine long hair and loose clothing (such as ties) in the laboratory. They may either catch fire or be chemically contaminated.
    - a. A laboratory apron or lab coat provides protection at all times. A lab apron or lab coat is required when you are wearing easily combustible clothing (synthetic and light fabrics).
    - b. It is advisable to wear old clothing to laboratory, because it is both generally not as loose and flammable as new clothing, and not as expensive to replace.
  13. Keep your work area neat at all times. Clean up spills and broken glass immediately. Clutter not only will slow your work, but it leads to accidents. Clean up your work space, including wiping the surface and putting away all chemicals and equipment, at the end of the laboratory period.
  14. Be careful when heating liquids; add boiling chips to avoid “bumping”. Flammable liquids such as ethers, hydrocarbons, alcohols, acetone, and carbon disulfide must never be heated over an open flame.
  15. Always pour acids into water when mixing. Otherwise the acid can spatter, often quite violently. Pour acid into water.
  16. Do not force a rubber stopper onto glass tubing or thermometers. Lubricate the tubing and the stopper with glycerol or water. Use paper or cloth towelling to protect your hands. Grasp the glass close to the stopper.
  17. Dispose of excess liquid reagents by flushing small quantities down the sink. Consult the teacher about large quantities. Dispose of solids in crocks. Never return reagents to the dispensing bottle.
  18. Carefully read the experiment and answer the questions in the prelab before coming to the laboratory. An unprepared student is a hazard to everyone in the room.
  19. Spatters are common in chemistry laboratories. Test tubes being heated or containing reacting mixtures should never be pointed at anyone. If you observe this practice in a neighbour, speak to him or her or the teacher, if needed.
  20. If you have a cut on your hand, be sure to cover with a bandage or wear appropriate laboratory gloves.
  21. Finally, and most important, think about what you are doing. Plan ahead. Do not cookbook. If you give no thought to what you are doing, you predispose yourself to an accident.

Do you have any diagnosed allergies or other special medical needs (check one)?

Yes \_\_\_\_\_ No \_\_\_\_\_

If yes, please list them in this space.

I have read and understand the Laboratory Safety Rules and have retained a copy for my reference.

\_\_\_\_\_

(Name)

\_\_\_\_\_

(Date)

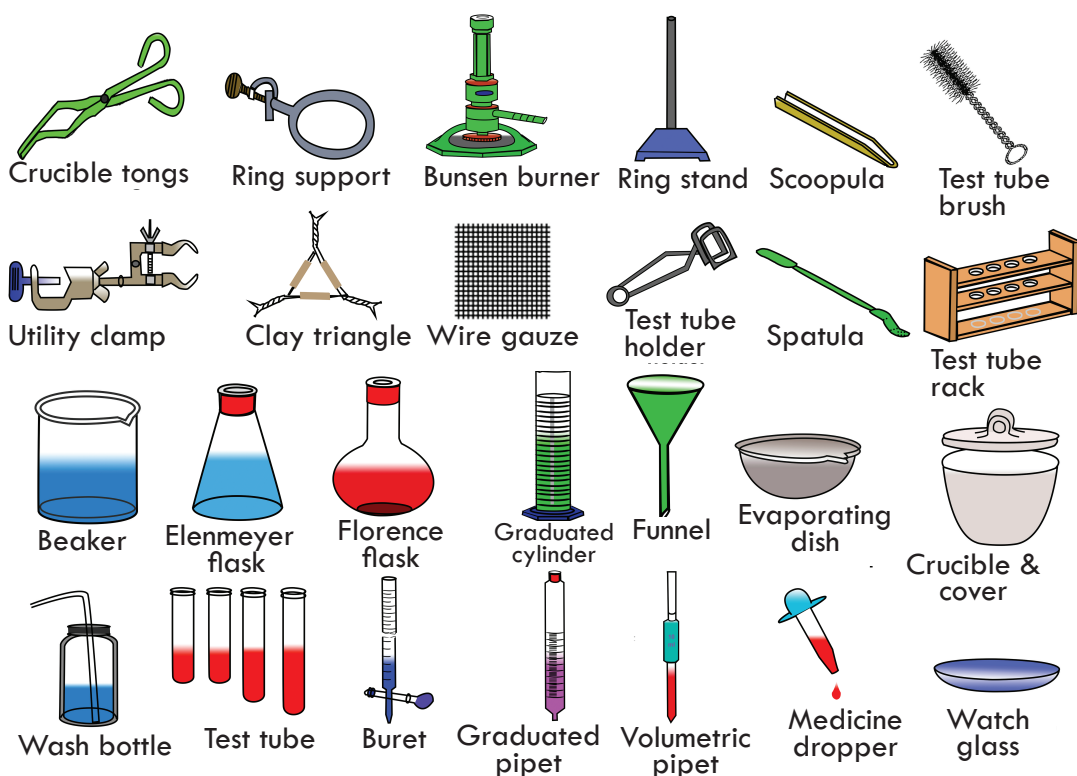
## Chemistry Grade 9

The first and foremost rule of any laboratory is to be safe! This may seem obvious, but people often disregard safety protocols for one reason or another, putting themselves and those around them in danger. The best thing you can do is to make sure you follow all safety protocols at all times.

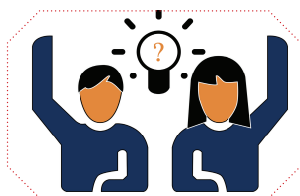
Safety goggles are required wear in all chemistry labs. Not wearing them puts you in danger of eye irritation and possibly blindness in the case of an accident. A small droplet of acid could splash out of the container at any time. Better safe than permanently blinded! Latex gloves should be used when there is a possibility of corrosive chemicals spilling onto your hands. A lab apron or coat can also prevent injury in case of spills or splashes.

A beaker is a common container in most labs. It is used for mixing, stirring, and heating chemicals. Most beakers have spouts on their rims to aid in pouring. They also commonly have lips around their rims and markings to measure the volume they contain, although they are not a precise way to measure liquids. Beakers come in a wide range of sizes. Because of the lip that runs around the rim, a lid for a beaker does not exist. However, a watch glass can be used to cover the opening to prevent contamination or splashing.

**Figure 2.9** shows some of the commonly used laboratory equipments.



**Figure 2.9** Commonly used Laboratory Equipment.



### Activity 2.6

Conduct the following activity and present your finding to the class.

Laboratory equipment

List down laboratory equipment you know and that are not shown in **Figure 2.9**. Describe their use. Which of them are used for measurement?

## 2.2.3 Writing a Laboratory Report

### A. The Pre-laboratory Report

Each experiment in this manual includes a pre-laboratory (prelab) report. The prelab report is to be completed before the experiment is begun in the laboratory. Its purpose is to ensure familiarity with the procedure and provide for a more efficient utilization of limited laboratory time. The prelab questions can be answered after a careful reading of the introduction and procedure of the experiment. Sample calculations are sometimes included to provide awareness of data that needs to be collected and how it is treated. Your teacher may prefer to administer prelab quizzes instead of collecting prelab reports.

### B. The Laboratory Report

A good laboratory report is the essential final step in performing an experiment. It is in this way that you communicate what you have done and what you have discovered. Since it is the only means, in many instances, of reporting results, it is important that it be prepared properly.

A laboratory report is a final draft. As such it is always written in ink or typed. A typed laboratory report is necessary if your handwriting is hard to read. There must be no erasures or crossed out areas. The initial draft of a laboratory report belongs in your laboratory notebook for two reasons.

1. It is unlikely that you will get everything correct on the first attempt and, thus, a first draft written on the report form itself could be very messy.
2. If the report itself is lost or destroyed, you can easily and quickly rewrite the report from the notebook.

It is essential that a laboratory report be neat. Studies have shown that when the same work is submitted in both neat and sloppy form, the neat version makes the better impression. Neat work indicates that the writer knows and cares about the subject matter.

All data should be presented with the correct significant figures and units. The omission of units makes it difficult for the reader to know the size of the numbers being reported. And writing down the wrong number of significant figures amounts to lying about the precision of the data. Too many significant figures imply that you know a number more

precisely than you actually do.

All questions should be answered with complete and grammatically correct sentences. Abbreviations should not be included in written answers. Read the sentence out loud to make sure that it makes sense.

Your sample computations should be labeled with their purpose, for example; “mass of the liquid”. Within the computation, all numbers must have the correct units and the correct number of significant figures.

Laboratory reports that extend to more than one page should either be stapled together or have your name and the page number at the top right of each page. For example: Terhas Asgedom, page 2 of 4 pages. This makes it more difficult for the instructor to inadvertently misplace pages. Using a paper clip or tearing corners to hold pages together is not acceptable. Reports should also be dated.

### Graphs

Graphs are used to present the data in picture form so that they can be more readily grasped by the reader. Occasionally, a graph is used to follow a trend. Notice that the best smooth curve is drawn through the data points. This is not the same as connecting the dots; all of the data points will not fall on the line. Often, however, a graph is used to show how well data fit a straight line. The line drawn may either be visually estimated (“eyeballed”) or computed mathematically. There are many essential features of a good graph.

1. The axes must be both numbered and labeled. The abscissa is the right-to-left or the horizontal axis or x-axis.
2. The graph must have a title. When we speak of graphing, we always mention the quantity plotted on the ordinate first.
3. The data points are never graphed as little dots. One may use small circles, small circles with a dot inside, crosses, asterisks, or X’s. If dots are used, data are too easily lost on the graph or “created” by stray blobs of ink.
4. Any lines that appear on the graph in addition to data points should be explained. Thus, the line drawn is explained in the title as “(visually estimated best straight line).”
5. The scales of the axes should be adjusted so that the graph fills the page as much as possible.

### Measurements and Density

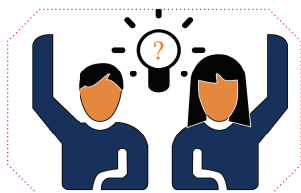
Chemistry is very much an experimental science in which careful and accurate measurements are the very essence of meaningful experimentation. It is, therefore, essential for the beginning student to learn how scientific measurements are carried out properly through the use of common measuring instruments. It is equally important for the student to acquire an appreciation of the significance of measurements and to



apply learned technique to a common specific experiment.

In the following experiment you will become familiar with how mass and volume measurements are carried out and how an evaluation of the measurements is reflected in the number of significant figures recorded. These mass and volume measurements will then be used to determine the density of (1) a metal bar and (2) a salt solution by two different methods. Finally, the results of the density measurements will be evaluated with respect to their precision and accuracy.

The density of an object is one of its most fundamental and useful characteristics. As an intensive property it is independent of the quantity of material measured since it is the ratio of the mass of an object to its volume. The density of an object can be determined by a variety of methods. In this experiment you will practice using a balance to measure mass. In addition, you will learn how to measure volume using a graduated cylinder and a pipet and learn how to calibrate the pipet. A comparison of the results allows for the calculation of the relative average deviation, which is a measure of the precision of the experiment.



### Activity 2.7

#### Intensive and extensive properties

Define the terms intensive and extensive properties. List down examples of intensive and extensive property.

Also, in the case of the metal bar, the results of measuring the density of the bar may be compared with the accepted density value for the bar. Thereby the relative error (a measure of accuracy) for the density of the bar may be determined. The sections in the Introduction to this laboratory manual pertaining to precision, accuracy, significant figures, and the laboratory notebook should be studied carefully before performing this experiment.

#### Materials and Chemicals

Cylindrical metal bars (Al, Cu, brass), approximately 51 cm (diameter), measuring rules (graduated in mm), 20 or 25 mL transfer pipets, 50 mL beaker, graduated cylinders (10 and 50 mL or 100 mL), 125 mL Erlenmeyer flask, stopper, thermometers, and balances with precision to 1 mg. Saturated salt solutions (NaCl and/or KCl are convenient) – about 36 g NaCl is required/100 mL. Estimated Time: 2-3 hours

#### Safety Precautions

Review the safety rules. Take special care in inserting the bar into the graduated cylinder. Do not drop it in! The glass cylinder may break. Pipeting should always be done using a suction device. Never suction by mouth.

### Procedures

Record all measurements in your laboratory notebook in ink. The proper use of a sensitive balance is critical to useful mass measurements. Also, pipeting is a very useful, accurate, and common method for transferring exact volumes of liquids. Therefore, the instructor should demonstrate good balance and pipet techniques to the class at the beginning of the laboratory period. Please note that when a portion of the experiment contains the instruction “Repeat . . . twice,” each portion is to be performed all the way through three times: initially and two repetitions.

### Part I: Measurements

#### A. Mass Measurements

After balance instruction, you will be assigned or allowed to select a balance for use during the experiment.

1. Zero the balance after cleaning the pan.
2. Measure the mass of a clean dry 50 mL beaker to the nearest  $\pm 0.001$  g.
3. Record, in ink, your observation directly into the lab notebook.
4. Remove the beaker from the pan. Again, clean the balance pan and zero the balance.
5. Weigh the same beaker as before (step 2) and record the result.
6. Repeat steps 4 and 5 one more time.
7. From the three mass measurements, calculate the average mass of the beaker.
8. Repeat steps 4 and 5 using a second balance (just one weighing).
9. Repeat steps 4 and 5 using a third balance (just one weighing).

#### B. Volume Measurements

Use of a pipet: In order to accurately measure a liquid volume using a pipet, you must consider several things. Most volumetric pipets are designed to deliver rather than to contain the specified volume. Thus, a small amount of liquid remains in the tip of the pipet after transfer of liquid. This kind of pipet is marked with the letters “TD” somewhere on the barrel above the calibration line. Also, for purpose of safety, never pipet by mouth; that is, never use your mouth to draw liquid into the pipet. Always use a suction device.

Use a clean but not necessarily dry 20 or 25 mL pipet. Rinse the pipet several times with small portions of the liquid to be transferred. To measure the desired volume, a volume of liquid greater than that to be measured is needed in order to keep the pipet tip under the liquid surface while filling.

While holding the pipet vertically, squeeze the air out of the suction device and hold it against the large end of the pipet, tight enough to obtain a seal. Keep the suction device evacuated and dip the pipet tip below the surface of the liquid, but do not touch the bottom of the container (A chipped tip causes error). Now release the suction device gently and allow liquid to fill the pipet until it is one to two cm above the calibration line etched onto the upper barrel. Quickly remove the suction device and

cover the end with your index finger before the liquid level falls below the line (some practice may be necessary). Wipe the outside of the tip with a clean piece of towel or tissue. With the tip touching the wall of the source container above the liquid level, allow it to drain until the meniscus rests exactly on the line. Now hold the pipet over the sample container and allow it to drain, but be careful to avoid loss from splashing. When the swollen part of the pipet is nearly empty, touch the tip to the wall of the container and continue draining. When the liquid level falls to the tip area, hold the tip to the glass for an additional 20 seconds and then remove. Do not blow out the remaining liquid.

1. Measure the temperature in the laboratory. Your teacher will provide you with the density of water at this temperature.
2. Use the same 50 mL beaker from Section A for determining the mass of each aliquot of water. Rather than re-weighing the empty beaker, the average mass of the beaker determined in Section A may be used as the mass of the dry beaker.
3. Measure 20 or 25 mL of water (depending on the size of pipet available) into the 50 mL beaker.
4. Record the volume of water measured with the pipet to the appropriate number of significant figures.
5. Record the number of significant figures in the volume measurement.
6. Weigh the beaker and water to the nearest mg ( $\pm 0.001$  g).
7. Calculate the mass of water in the beaker.
8. Use the mass and density of water to determine the volume of water measured.
9. Repeat steps 3 – 8 using a 50 or 100 mL graduated cylinder instead of the pipet to measure the 20 or 25 mL of water. Repeat steps 3 – 8 again using a graduated 50 mL beaker to measure the water.

### C. Calibration of a Volumetric Pipet

Your teacher may suggest that you calibrate your pipet. When you do so, use a pure liquid of known temperature. Usually water is most convenient to use. Pipet distilled water into a pre-weighed flask with stopper. After pipeting, weigh the flask, stopper, and add water. Use the measured mass of water and its density value at that temperature, given by your teacher, to calculate the volume of the liquid delivered by the pipet to four significant figures. Do at least three separate determinations.

### PART II: Density

#### A. Density of a Metal Bar (Use the same metal bar for all trials.)

1. Zero your balance. Weigh a metal bar on a balance sensitive to the nearest mg ( $\pm 0.001$  g). Repeat the entire weighing operation twice. Do not allow the first measurement that you obtain to influence subsequent measurements that you make. Make sure you zero the balance before proceeding with each measurement.
2. Determine the volume of the metal bar by each of the following methods,

making at least three measurements for each method. Do not allow the first measurement to influence subsequent measurements as your data will then be less significant for the purpose of measuring the precision of this experiment.

### Method I

Insert the bar into a graduated cylinder filled with enough water so that the bar is immersed. Note and record as precisely as possible the initial water level, and the water level after the bar is immersed. Read the lowest point of the meniscus in determining the water level and estimate the volume to one digit beyond the smallest scale division. Discard the water and repeat this measurement twice with a different initial volume of water. Calculate the average density of the bar.

### Method II

Measure the dimensions of the bar with a measuring stick ruled in centimetres. Repeat these measurements twice. Calculate the volume of the bar from these dimensions. Because the bar is cylindrical in shape, note that the formula for the volume of a cylinder should be used ( $V = \pi r^2 h$ ). Calculate the average density of the bar.

3. For each method, determine the relative error of your result comparing it with the accepted value as provided by your instructor or as found in a reference such as the Handbook of Chemistry and Physics.

Which one of the two methods is more accurate? Explain.

### B. Density of a Salt Solution

1. Weigh a 125 mL Erlenmeyer flask and stopper. With a clean 20.00 or 25.00 mL volumetric pipet, pipet the salt solution into the flask and reweigh. Repeat this measurement twice, with a different sample of the same solution. Calculate the average density of the salt solution.
2. Weigh an empty, dry 10 mL graduated cylinder. Fill with about 9-10 mL of salt solution, record the volume as precisely as possible, and reweigh. Repeat this measurement twice, with a different sample of solution each time. Calculate the average density of the salt solution.
3. For each method determine the relative average deviation of your results. Which method is more precise? Explain.

### Disposal

**Salt solutions:** Do one of the following, as indicated by your teacher.

- a. *Recycle:* Return the salt solution to its original container.
- b. *Treatment/disposal:* Dilute the salt solution 1:10 with tap water and flush down the sink with running water.
- c. *Disposal:* Put the salt solution in a waste bottle labeled inorganic waste.

Report \_\_\_\_\_ Name \_\_\_\_\_ Section \_\_\_\_\_

**Questions**

- From your data, calculate the volume occupied by 100 g of the following:
  - salt solution
  - metal bar
- From your answers to question 1 determine whether the metal bar or the salt solution occupies the larger volume. Explain your answer in the context of the densities of solids and liquids in general.
- Define the terms precision and accuracy in such a way as to distinguish between them.
- Are your results for the metal bar more precise or more accurate? Explain.
- From your data for the salt solution, evaluate the two methods in terms of their precision. Which method should lead to greater precision? Which method actually is more precise? Explain.

**Prelab****Measurements and Density**

The following data were obtained in order to determine the density of a cylindrical metal bar.

Trial 1	1	2	3
Height (cm)	6.50	6.45	6.44
Diameter (cm)	1.25	1.26	1.22
Mass (g)	46.683	46.332	47.014

In the following calculations on this data, show the formula used, the substituted numbers, and the result.

- Calculate the average density of the bar.
- Calculate the percent relative average deviation of the measurements.
- If the accepted value for the density of the bar is  $6.70 \text{ g/cm}^3$ , what is the percent relative error?
- Are these measurements more precise or more accurate? Explain.
- What is the purpose of repetition in measurements?

**Key terms**

☞ Accuracy	☞ Measured numbers
☞ Calibration	☞ Significant figures
☞ Derived units	☞ Scientific notations
☞ Decimal places	☞ Scientific method
☞ Error	☞ SI units
☞ Exact numbers	☞ Prefixes
☞ Laboratory safety	☞ Precision
☞ Laboratory equipment	☞ Uncertainty
☞ Measurement	

## Unit Summary

- ☞ The International System (SI) uses a particular selection of metric units. It employs seven base units combined with prefixes to obtain units of various sizes. Units for other quantities are derived from these.
- ☞ To obtain a derived unit in SI for a quantity such as the volume or density, you merely substitute base units into a defining equation for the quantity.
- ☞ SI units are used to express physical quantities in all sciences, including chemistry.
- ☞ Scientific notation helps us handle very large and very small quantities. Most measured quantities are inexact to some extent.
- ☞ The number of significant figures indicates the exactness of the measurement.
- ☞ Accuracy is defined as how closely a measured value agrees with the correct value.
- ☞ Precision is defined as closely repeated measurements of the same quantity agree with one another.
- ☞ Chemistry is an experimental science in that the facts of chemistry are obtained by experiment.
- ☞ The scientific method is a systematic approach to research that begins with the gathering of information through observation and measurements. In the process, hypotheses, laws, and theories are devised and tested.
- ☞ The key to significance in experimental measurements is repetition. Only with repeated measurements of the density, concentration, or other quantities can the experimenter have some confidence in the significance of measurements.

## Review Exercise

### Part I: Basic level questions.

#### Indicate True or False for the following Statements.

1. There is always a degree of uncertainty involved with every measurement.
2. Multiplication of 36,000 and 52.00 give the significant value 1872.000.
3. There are four significant numbers in 70.03.
4. While adding or subtracting a quantity, the answer contain no more decimal places than the least accurate measurement.
5. The significant figures in a number include all of the certain digits plus one doubtful digit.
6. In the following expression  $0.01208 \times 0.0236$ , the answer should be reported up to four decimal places.
7. It is desirable for the sides of a graduated cylinder to be perfectly vertical.

### Part II: Intermediate level questions.

For each question, four alternative choices are given, of which only one is correct. You have to select the correct alternative and mark it in the appropriate option.

8. Calculate the following using proper number of significant figures:  
 $(20.035 \times 0.03120) / (4 \times 0.333)$

- a. 0.47  
b. 0.40
- c. 0.469  
d. 0.4692
9. A sample of nickel weighs 7.5425 g and has a density of 8.8 g/cm<sup>3</sup>. What is the volume with the correct number of significant figures?  
a. 1.33 cm<sup>3</sup>  
b. 9.2 cm<sup>3</sup>  
c. 0.86 cm<sup>3</sup>  
d. None of the above
10. The mass of copper is 0.063546 kg and the density is 8.940 g/cm<sup>3</sup>. Calculate the volume using scientific figures.  
a. 7.108 cm<sup>3</sup>  
b. 7.10 cm<sup>3</sup>  
c. 7.1080 cm<sup>3</sup>  
d. 7.1 cm<sup>3</sup>
11. Which of the following statements are correct for a burette?  
a. The burette is designed to accurately deliver a volume of liquid  
b. The burette is used for measuring the volume of liquid used from the burette  
c. The burette volume can be measured to the hundredths place  
d. All of the above
12. When expressed as  $7.5 \times 10^4$ , only the significant figures of \_\_\_\_\_ are to be considered.  
a. 7.5  
b. 7.05  
c. 7.005  
d. None of the above
13. The mass of an element is  $.007502 \times 10^{-26}$  g. Find the number of significant figures when the mass is converted to mg. (Both mass values have same order of magnitude)  
a. 4  
b. 5  
c. 3  
d. 2
14. A cube like crystal structure has length 6.000 cm, width 6.00 cm and height 0.0600 m. Calculate its volume with correct significant figures.  
a. 216 cubic cm  
b. 21.600 cubic cm  
c. 18.00 cm  
d. None of the above
15. What is the sum of  $22.82 + 2.2457$  with the correct number of significant figures.  
a. 25.065  
b. 25.09  
c. 25.06  
d. 25.0651
16. The weights of sodium chloride salt in three petri dishes are 99.99 g, 100.13 g, and 100.23 g respectively. Which of the following is the average mass of salt?  
a. 100.1166 g  
b. 100.116 g  
c. 100.11 g  
d. 100.1 g
17. Which of the following expresses the one millionth of one in 3 significant places?  
a.  $0.01 \times 10^{-6}$   
b.  $0.10 \times 10^6$   
c.  $0.001 \times 10^{-6}$   
d.  $1.00 \times 10^{-6}$
18. Calculate the number of significant figures up to which  $(2.36 \times 0.07251) / (2.103)$  will be expressed.  
a. 2  
b. 3  
c. 4  
d. 5

## Chemistry Grade 9

### Part III: Advanced level questions.

#### Answer the following questions.

19. Give the SI units for expressing these:
- |            |           |                 |
|------------|-----------|-----------------|
| a. length, | d. mass,  | g. energy,      |
| b. area,   | e. time,  | h. temperature. |
| c. volume, | f. force, |                 |
20. Write the numbers for these prefixes:
- |          |           |          |
|----------|-----------|----------|
| a. mega- | d. centi- | g. nano- |
| b. kilo- | e. milli- | h. pico- |
| c. deci- | f. micro- |          |
21. Define density. What units do chemists normally use for density?
22. Write the equations for converting degrees Celsius to degrees Fahrenheit and degrees Fahrenheit to degrees Celsius.
23. Carry out the following arithmetic operations to the correct number of significant figures:
- |  |  |
|--|--|
| a. $12,343.2 \text{ g} + 0.1893 \text{ g}$ | d. $0.0239 \text{ kg} \div 46.5 \text{ mL}$                    |
| b. $55.67 \text{ L} - 2.386 \text{ L}$     | e. $5.21 \times 10^3 \text{ cm} + 2.92 \times 10^2 \text{ cm}$ |
| c. $7.52 \text{ m} \times 6.9232$          |  |
24. Carry out the following arithmetic operations and round off the answers to the appropriate number of significant figures:
- |  |  |
|--|--|
| a. $26.5862 \text{ L} + 0.17 \text{ L}$ ,                            | d. $6.54 \text{ g} \div 86.5542 \text{ mL}$ ,                      |
| b. $9.1 \text{ g} - 4.682 \text{ g}$ ,                               | e. $(7.55 \times 10^4 \text{ m}) - (8.62 \times 10^3 \text{ m})$ . |
| c. $7.1 \times 10^4 \text{ dm} \times 2.2654 \times 10^2 \text{ dm}$ |  |
25. Carry out each of the following conversions.
- |                  |                  |                            |
|------------------|------------------|----------------------------|
| a. 18.5 m to km; | c. 247 kg to g;  | e. 85.9 dL to L;           |
| b. 16.3 km to m; | d. 4.32 L to mL; | f. 8251 L to $\text{cm}^3$ |
26. Express
- |                                  |   |
|----------------------------------|---|
| a. $283^\circ\text{C}$ in K;     | c. $32.0^\circ\text{C}$ in $^\circ\text{F}$ ; |
| b. 15.25 K in $^\circ\text{C}$ ; | d. $100.0^\circ\text{F}$ in K.                |
27. Express
- |  |   |
|--|---|
| a. $0^\circ\text{F}$ in $^\circ\text{C}$ ; | c. 298 K in $^\circ\text{F}$ ;                |
| b. $98.6^\circ\text{F}$ in K;              | d. $11.3^\circ\text{C}$ in $^\circ\text{F}$ . |
28. Percent error is often expressed as the absolute value of the difference between the true value and the experimental value, divided by the true value:

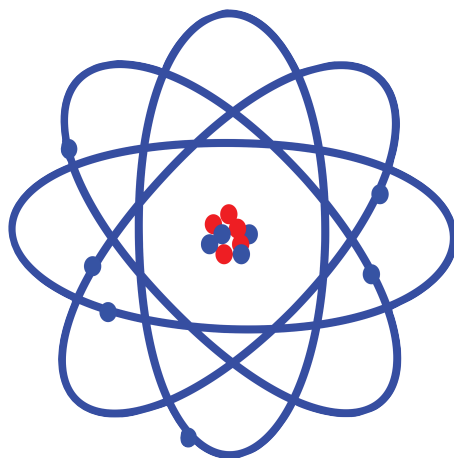
$$\text{Percent error} = \frac{|\text{True value} - \text{Experimental value}|}{|\text{True value}|} \times 100$$

Where the vertical lines indicate absolute value. Calculate the percent error for these measurements:

- a. The density of alcohol (ethanol) is found to be 0.802 g/mL. (True value: 0.798 g/mL.)
- b. The mass of gold in an earring is analyzed to be 0.837 g. (True value: 0.864 g.)



# UNIT 3



## STRUCTURE OF THE ATOM

### Unit Outcomes

At the end of this unit, you will be able to

- ☞ discuss the development of Dalton's Atomic Theory and Modern Atomic Theory;
- ☞ explain the discovery of the proton, electron, neutron and the nucleus;
- ☞ differentiate the terms like atomic number, mass number, atomic mass, isotope, energy level, valence electrons and electron configuration;
- ☞ develop skills in determining the number of protons, electrons and neutrons of atoms from atomic numbers and mass numbers,
- ☞ develop skills in
  - ☞ calculating the atomic masses of elements that have isotopes;
  - ☞ writing the ground-state electron configurations of atoms using main energy levels and drawing diagrammatic representations of atoms;
- ☞ demonstrate scientific inquiry skills: observing, comparing and contrasting, communicating, asking questions, and applying concepts.





### Start-up Activity

Students make groups and discuss on the following questions and present your discussion points to the class.

1. What is the smallest seed you have ever known?
2. What is it made of?
3. Did you know what its inside and outside looks like?
4. How easy is it to draw its inside and outside?



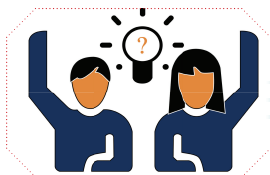
The existence of atoms has been proposed since the time of early Indian and Greek philosophers (400 B.C.) who were of the view that atoms are the fundamental building blocks of matter. According to them, the continued subdivisions of matter would ultimately yield atoms which would not be further divisible. The word 'atom' has been derived from the Greek word 'a-tomos' which means 'uncuttable' or 'non-divisible'. These earlier ideas were mere speculations and there was no way to test them experimentally. These ideas remained dormant for a very long time and were revived again by John Dalton in the beginning of nineteenth century in terms of his atomic theory. The atomic theory of matter was first proposed on a firm scientific basis by John Dalton, a British school teacher in 1808. His theory, called Dalton's atomic theory, regarded the atom as the ultimate particle of matter.

### 3.1 Historical Development of the Atomic Theories of Matter

At the end of this section, you will be able to state briefly the history of development of atomic nature of substances.

Students, form groups and discuss the following questions. Present your discussion points to the class when you are asked by your teacher.

1. What are the simplest components of wood, rocks, and living organisms? In other words, what could you find if you split these materials to the least possible limit?
2. The Universe in which we live is so vast and contains the stars, the Sun, the Moon, the planets, dust, air, water, soil and other materials. Do you know what all these things are made of?
3. What do you think is the importance of knowing the nature of substances?



### Activity 3.1

A scientific theory is a well-tested, broad explanation of a natural phenomenon. In

everyday life, we often use the word theory to mean a hypothesis or educated guess, but a theory in the context of science is not simply a guess. It is an explanation based on extensive and repeated experimentation. Because it is so well supported, a scientific theory has a very good chance of being a correct explanation for events in nature. Since it is a broad explanation, it can explain many observations and pieces of evidence. In other words, it can help connect and make sense of many phenomena in the natural world. Chemistry is full of abstract concepts that deal with the microscopic world. To explain these abstract and microscopic concepts, scientists spent a lot of time and energy. In this section, we are going to see the origin of the Atomic Theory.

All modern scientists accept the concept of the atom, but when the concept of the atom was first proposed about 2,500 years ago, ancient philosophers laughed at the idea. It has always been difficult to convince people about the existence of things that are too small to see. We will spend some time considering the evidence (observations) that convince scientists of the existence of atoms.

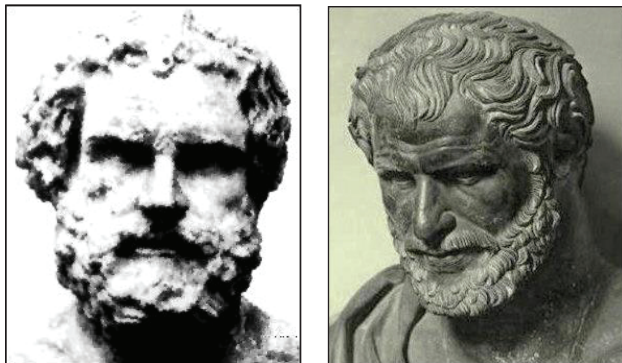
### The Indivisible Atom

Greek philosophy was emerged early in the 6<sup>th</sup> century BC, centered in the city of Miletus on the Ionian coast in Asia Minor (now called Turkey). In the middle of the 5<sup>th</sup> century BC, an ancient Greek philosopher, Empedocles, thought that all materials are made up of four things called elements: *earth, air, water, and fire*.

**Plato** (student of Socrates and teacher of Aristotle) adopted Empedocles' Theory, and coined the term element to describe these four substances. His successor, Aristotle, also adopted the concept of four elements. He introduced the idea that elements can be differentiated based on properties such as hot versus cold, and wet versus dry. For example, heating clay in an oven could be thought of as driving off water and adding fire, transforming clay into a pot. Similarly, water (cold & wet) falls from the sky as rain, when air (hot and wet) cools down. The Greek concept of four elements existed for more than two thousand years.

Democritus (460-370 B.C) was a Greek philosopher born in Abdera in the north of Greece. Democritus was a student of Leucippus, who proposed the atomic theory of matter. There is little documentation on the philosophy of Leucippus. It was Democritus, who elaborated extensive works on his theories on the atomic structure of the physical world, of the universe, and the void of space. Although Democritus was a philosopher, he is included among the list of great pioneers of physics and chemistry of the 19<sup>th</sup> and 20<sup>th</sup> centuries. This is because many of his teachings on the structure of matter were demonstrated by scientists over 2000 years after his death.

Democritus taught the theory of atomism, which held the belief that indivisible and indestructible atoms are the basic components of all matter in the universe. Thus the word atom is derived from the Greek atomos meaning indivisible



**Figure 3.1** From left to right: Democritus, and Leucippus of Miletus.

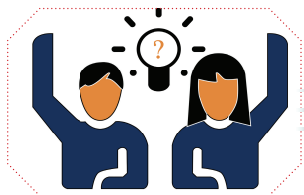


### Exercise 3.1

Give the correct answer for the following questions.

1. According to the Greek philosopher Empedocles, what are the four elements that all materials are made up of?
2. What is the contribution of Plato and Aristotle to the Atomic Theory?

### The Greek Concept of 'Atomos'



#### Activity 3.2

Students, discuss in groups of two or three the following questions and present your discussion points to the class.

1. If you were given the right to name the smallest thing you obtained after splitting a substance to the possible limit, what do you call it?
2. Why do you give that name?
3. Do you think it is the right term to describe the smallest particle from which every substance is made up of?

About 2,500 years ago, early Greek philosophers believed the entire universe was a single, huge, entity. In other words, “everything was one.” They believed that all objects, all matter, and all substances were connected as a single, big, unchangeable ‘thing’.

Around 440 BC, Leucippus of Miletus originated the atom concept. He and his pupil, Democritus (c 460 - 371 BC) of Abdera, refined and extended it in future years. The work of Leucippus and Democritus was further developed by Epicurus (341 - 270 BC), who made the ideas more generally known. Aristotle (384 - 322 BC) quotes both of them extensively in arguing against their ideas. There are five major points to their atomic idea.

- i. All matter is composed of atoms, which are bits of matter too small to be seen. These atoms cannot be further split into smaller portions. Democritus reasoned that if matter could be infinitely divided, it was also subjected to complete disintegration from which it can never be put back together. In Greek, the prefix 'a' means 'not' and the word 'tomos' means 'cut'. Our word atom, therefore, comes from *atomos*, a Greek word meaning uncuttable.
- ii. There is a void, which is an empty space between atoms. Leucippus believed in the existence of an empty space between atoms. Given that all matter is composed of atoms, then all changes must be as a result of the movement of atoms. However, to move there must be a void; a space entirely empty of matter through which atoms can move from place to place. The problem with this assumption is that, if there is an entirely void space between atoms, then what held the atoms together? Leucippus and Democritus did not answer this question.
- iii. Atoms are completely solid. This means that there can be no void inside an atom itself. An atom would be subjected to changes from outside and could disintegrate, otherwise. Then, it would not be an atom.
- iv. Atoms are homogeneous, with no internal structure. The absolute solidity of the atoms also leads to the notion that atoms are homogeneous, or the same all the way through. Another way to express this is that an atom would have no internal structure.
- v. Atoms are different in their sizes, shapes, and weight. Democritus then reasoned that changes occur when the many *atomos* (now known as *atoms*) in an object were reconnected or recombined in different ways. Democritus even extended this theory suggesting that there were different varieties of *atomos* with different shapes, sizes, and masses. He thought, however, that shape, size, and mass were the only properties differentiating the different types of *atomos*. According to Democritus, other characteristics like color and taste did not reflect properties of the *atomos* themselves, but rather, resulted from the different ways in which the *atomos* were combined and connected. The generally accepted atomic model of Democritus is called 'the solid sphere'.

However, since Aristotle and other prominent thinkers of the time strongly opposed their idea of the atom, their theory was disregarded and essentially buried until the 16<sup>th</sup> and 17<sup>th</sup> centuries. In time, Lavoisier's innovative 18<sup>th</sup>-century experiments accurately measured all substances involved in the burning process, proving that "when substances burn, there is no net gain or loss of weight." Lavoisier established the **science of modern chemistry**, which gained greater acceptance. This is because of the efforts of John Dalton, who modernized the ancient Greek ideas of element, atom, compound, and molecule. Dalton also provided a means of explaining chemical reactions in quantitative terms.

### Drawbacks of the Early Greek Philosophers

The early Greek philosophers tried to understand the nature of the world through **reason** and **logic**, but not through **experiment** and **observation**. As a result, they had some very thought-provoking ideas, but they felt no need to justify their ideas based on life experiences. In a lot of ways, you can think of the Greek philosophers as being “**all thought and no action**.” It’s truly amazing how much they achieved using their minds, but because they never performed any experiments, they missed or rejected a lot of discoveries that they could have made otherwise. Greek philosophers dismissed Democritus’ Theory entirely. Sadly, it took over two millennia before the theory of atomos (or ‘atoms’ as they are known today) was fully appreciated.



### Exercise 3.2

Give the correct answer for the following questions.

1. Where, by whom, and when was the concept ‘atom’ was originated?
2. What does the word ‘atom’ mean?
3. What are the five major points of the atomic ideas, according to the Greek philosophers?
4. According to the ancient Greek philosophers, what do you think is an atom like? Can you draw it in your exercise book?
5. What example can you give, from a local material around you, that you think looks like an atom?

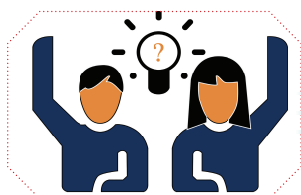
## 3.2 Fundamental Laws of Chemical Reactions

We are living in a world full of laws. **Laws** are generalized observations about a relationship between two or more things in the natural world. **Scientific laws** or **laws of science** are statements, based on repeated experiments or observations, that describe or predict a range of natural phenomena. They don’t explain why the phenomenon exists or what causes it. The explanation of a phenomenon is called a **scientific theory**. **Chemical Laws** are those laws of nature relevant to chemistry. In this section, we are going to discuss some of the chemical laws.

### 3.2.1 The Law of Conservation of Mass

At the end of this section, you will be able to

- ☞ state the law of conservation of mass and illustrate using examples.
- ☞ describe the law of conservation of mass using simple experiments.



### Activity 3.3

Students, form a group of two or three and discuss the following questions. Present your discussion points to the class.

1. Which direction is water flowing in your locality, from an area of high to low or from low to high altitude?
2. Will the direction of flow of water change in places other than your locality? How?
3. If you dissolve 3g of sugar in 20 g of water, how many grams of a sugar solution will you get? Is it correct if we write: sugar (3g) + water (20 g) = sugar solution (23 g)?
4. What will happen to the mass of pieces of campfire wood after burning it? Do you think the mass of the pieces of the campfire wood is equal to the mass of the ash we get from burning it? Why?

In science, a law is a general statement that explains a large number of observations. Before being accepted, a law must be verified many times under many conditions. Laws are, therefore, considered the highest form of scientific knowledge, and are generally supposed to be **unbreakable**. Scientific laws form the core of scientific knowledge. One scientific law that provides the foundation for understanding in chemistry is the **Law of Conservation of Mass**. The law of conservation of mass is also known as the '**Law of Indestructibility of Matter**'. It states that in any given system that is closed to the transfer of matter (in and out), the amount of matter in the system stays unchanged. A simple way of expressing this law is to say that the amount of matter in a system is conserved.

The Law of Conservation of Mass dates from **Antoine Lavoisier's** 1789 discovery that mass is neither created nor destroyed in chemical reactions. In other words, the mass of any one element at the beginning of a reaction will equal the mass of that element at the end of the reaction. If we account for all reactants and products in a chemical reaction, the total mass will be the same at any point in time in any closed system. These laws are called the **Laws of Chemical Combination**. Ten years later, Joseph Louis Proust proposed the **Law of Definite Proportions**, which states that the masses of elements in a compound always occur in the same proportion. Lavoisier's finding laid the groundwork for modern chemistry and revolutionized the science.

These theories didn't reference atoms, yet John Dalton built upon them to develop the **Law of Multiple Proportions**, which states that the ratios of masses of elements in a compound are small whole numbers. Dalton's Law of Multiple Proportions drew from experimental data. He proposed that each chemical element consists of a single type

## Chemistry Grade 9

of atom that could not be destroyed by any chemical means. These ultimately formed the basis of **Dalton's Atomic Theory of Matter**. His work marked the beginning of the scientific atomic theory.

According to the **Law of Conservation of Mass**, during any chemical change, the total mass of the products remains equal to the total mass of the reactants. The mass of Reactants 1 & 2 is equal to the mass of Products 1 & 2.



The Law of Conservation of Mass holds true because naturally occurring elements are very stable at the conditions found on the surface of the Earth. In the everyday world of Earth, from the top of the highest mountain to the lowest point of the deepest ocean, atoms are not changed to other elements during ordinary chemical reactions.



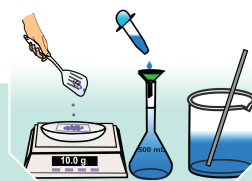
### Exercise 3.3

Give the correct answer for the following questions.

1. Define the term 'law'.
2. What is a 'scientific law'?
3. What is the difference between a 'scientific law' and a 'scientific theory'?
4. What is a Chemical Law?
5. Who discovered the Law of Conservation of Mass?
6. State The Law of Conservation of Mass.

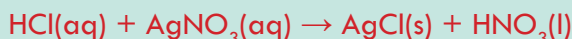
### Experiments on The Law of Conservation of Mass

The objective of the experiments is to practically show the application of the Law of Conservation of Mass in chemical reactions. These experiments could help you developing a scientific attitude, in working together, and in being honest.



#### Experiment 3.1

The reaction between silver nitrate solution and dilute hydrochloric acid



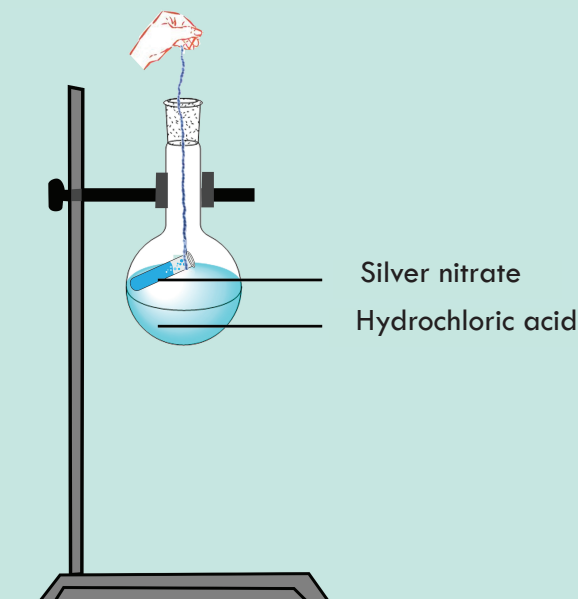
**Materials you need:** conical flask, thread, cotton, test tube, safety goggles, gloves, balance and glass rod.

**Chemicals:** hydrochloric acid, silver nitrate solution.



**Procedure:** Please follow the following procedures.

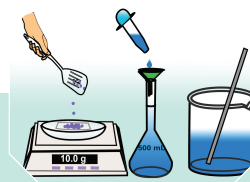
1. Place dilute HCl in a conical flask to a depth of about 1 cm.
2. Tie a thread of cotton around the top of a test tube.
3. Half fill the test tube with silver nitrate solution.
4. Place the test tube inside the conical flask so that it is held on a slant by the thread and place a bung in the top of the flask to hold the thread in place.
5. Weigh the conical flask and contents.
6. Tilt the flask so that the silver nitrate solution should be poured into the dilute hydrochloric acid and a white precipitate of silver chloride is produced (**Figure 3.2**).
7. Reweigh the conical flask and contents.
8. Remove the test tube from the inside of the conical flask. Discard the contents of the conical flask into the waste tank prepared for this purpose. Discard the thread, the cotton, and the gloves on the proper dust bin prepared for this purpose.
9. Wash the test tube and the conical flask and dry them in an oven. Put them on their proper places.



**Figure 3.2** Set up for the reaction between silver nitrate solution ( $\text{AgNO}_3$ ) and dilute hydrochloric acid (HCl).

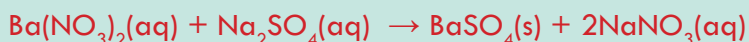
Observation and analysis questions

1. What is the mass of the conical flask and its contents before the reaction?
2. What is the mass of the conical flask and its contents after the reaction?
3. Does this experiment confirm the Law of Conservation of Mass?



### Experiment 3.2

The reaction between barium nitrate and sodium sulphate

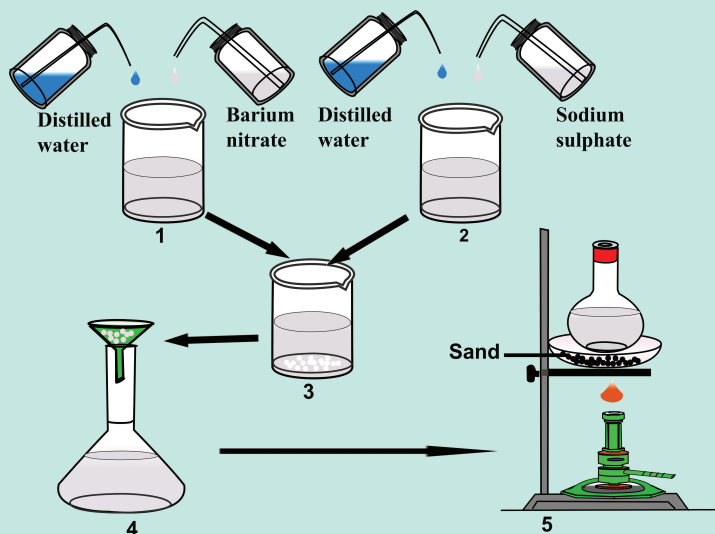


**Materials:** beakers (250 & 150 mL), Whatman filter paper, Erlenmeyer flask, funnel, sand bath, metal stand, metal ring, clamps, Bunsen burner, balance, glass rod.

**Chemicals:** Barium nitrate, sodium sulphate, distilled water.

**Procedure:** Please follow the following procedures

1. To 150 mL beaker add 100 mL distilled water and 2.61 g of  $\text{Ba}(\text{NO}_3)_2$  and stir vigorously until it dissolves. This will make a 0.1M  $\text{Ba}(\text{NO}_3)_2$  solution.
2. To 150 mL beaker add 100 mL distilled water and 1.42 g of  $\text{Na}_2\text{SO}_4$  and stir vigorously until it dissolves.
3. Mix the solutions in 250 mL beaker and stir the contents very well.
4. Filter off the white insoluble  $\text{BaSO}_4$  using filter paper and dry it in an oven at  $40^\circ\text{C}$ . Weigh the  $\text{BaSO}_4$ .
5. Evaporate the water from the filtrate on a sand bath and weigh the residue of  $\text{NaNO}_3$ .
6. Keep the  $\text{BaSO}_4$  and  $\text{NaNO}_3$  in separate bottles, label them and put it on the chemical shelf.
7. Clean, dry and put the beakers on the cupboard.



**Figure 3.3** Set up for the reaction between barium nitrate ( $\text{Ba}(\text{NO}_3)_2$ ) and sodium sulphate ( $\text{Na}_2\text{SO}_4$ ).

Observation and analysis questions:

Give the correct answer for the following questions.

1. What is the mass of the barium sulphate?
2. What is the mass of the sodium nitrate?
3. What is the mass of the water used in the experiment?
4. Is this experiment in agreement with the Law of Conservation of Mass?
5. Express the Law of Conservation of Matter in your own words.
6. Explain why the concept of conservation of matter is considered a scientific law.
7. Potassium hydroxide (KOH) readily reacts with carbon dioxide ( $\text{CO}_2$ ) to produce potassium carbonate ( $\text{K}_2\text{CO}_3$ ) and water ( $\text{H}_2\text{O}$ ). How many grams of potassium carbonate is produced if 224.4 g of KOH reacted with 88.0 g of  $\text{CO}_2$ . The reaction also produced 36.0 g of water.

### 3.2.2 The Law of Definite Proportions

At the end of this section, you will be able to state the Law of Definite Proportions.

Before directly delving into The Law of Definite Proportions we shall see how to calculate the molecular weights and moles of molecules. First we shall discuss how to calculate the molecular weights of molecules. In the previous unit you have come across the concept of average atomic mass of elements (the detail shall be discussed in 3.5.3). The molecular weight of a substance is the sum of the atomic masses of all atoms in a molecule, based on a scale in which the atomic masses of hydrogen, carbon, nitrogen, and oxygen are 1, 12, 14, and 16, respectively.

**Problem:** Calculate the molecular weight of ammonia ( $\text{NH}_3$ ).

**Solution:** First calculate the atomic masses of the atoms in ammonia.

Mass of nitrogen = 14 and we have only one nitrogen atom.

Mass of hydrogen = 1 however we have four hydrogens and therefore the total mass of hydrogen in ammonia will be  $1 \times 4 = 4$ .

Now add all the atomic masses.

Mass of ammonia = mass of nitrogen + mass of hydrogen =  $14 + 4 = 18$ .

The mole is defined as the amount of substance of a system which contains as many elementary entities as there are atoms in 0.012 kilogram of carbon 12; its symbol is "mol". One can calculate the number of moles of a compound or molecule by dividing the mass of the compound by its molecular mass. The number of moles will be discussed further in Grade 10, unit 2 under ways of expressing concentrations of solutions.

$$\text{Number of moles} = \frac{\text{given mass}}{\text{molecular mass}}$$

Problem: Calculate the number of moles of 2 g of ammonia ( $\text{NH}_3$ ).

Solution

$$\begin{aligned}\text{Number of moles} &= \frac{\text{given mass of NH}_3}{\text{molecular mass of NH}_3} \\ &= (2 \text{ g}) / (17 \text{ g}) = 0.11\end{aligned}$$

**Law of Definite Proportions**, also known as **Proust's Law** or the **Law of Constant Composition** states that every chemical compound contains fixed and constant proportions (by mass) of its constituent elements. To understand this, let us consider the following examples.

**Example 3.1:** Carbon dioxide ( $\text{CO}_2$ ) is composed of one carbon atom and two oxygen atoms. Therefore, by mass, carbon dioxide can be described by the fixed ratio of 12 (mass of carbon) : 32 (mass of oxygen) or simplified as 3:8.

**Example 3.2:** Let us take, for example, a water molecule ( $\text{H}_2\text{O}$ ). Whatever the source of water, its composition is that of two atoms of hydrogen and one atom of oxygen. If we calculate the molecular weight of water, we come up with 18 g/mol. In 1 mole of water, there are 2 grams of hydrogen and 16 grams of oxygen. In other words, hydrogen and oxygen are in a ratio of 1:8 in water. The Law of Definite Proportions illustrates that whatever the amount of water, whether it be 2 g or 54 g, the ratio of the amount of hydrogen to oxygen by weight will always be the same.



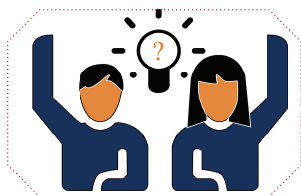
### Exercise 3.4

Give the correct answers for the following questions.

1. Define Proust's Law or the Law of Definite Proportions.
2. What is the ratio of hydrogen to oxygen (by weight) in 25 g  $\text{H}_2\text{O}$ ?
3. What is the ratio of carbon to hydrogen to oxygen (by weight) in 25 g ethanol ( $\text{C}_2\text{H}_6\text{O}$ )?

### 3.2.3 The Law of Multiple Proportions

At the end of this section, you will be able to state the Law of Multiple Proportions.



### Activity 3.4

Students, form groups and discuss the following questions. Present your discussion points to the class.

1. Mention the two compounds that are formed from hydrogen and oxygen.
2. The atomic mass of hydrogen is 1 g and mass of oxygen is 16 g. What are the mass-ratios of the two elements in the compounds mentioned in question #1?
3. What is a whole number? Can you give examples of small whole numbers?

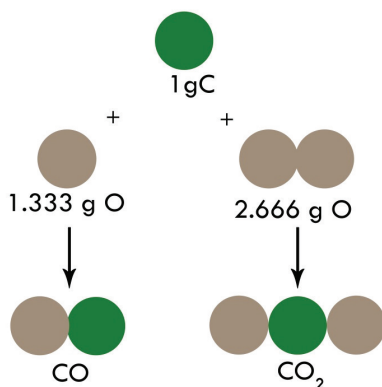
**The Law of Multiple Proportions** states that, when two different compounds are formed from the same two elements, the masses of one element, which react with a fixed mass of the other, are in a ratio of small whole numbers. Let us consider the following examples so that we could understand this law.

**Example 3.3:** Let us consider the two compounds formed by carbon and oxygen. In one of them (carbon monoxide; CO), we find 1.33 g of oxygen combined with 1.00 g of carbon while in the second (carbon dioxide; CO<sub>2</sub>), there are 2.66 g of oxygen combined with 1.00 g of carbon. What is the ratio of the masses of oxygen in CO and CO<sub>2</sub> that combines with a fixed mass of carbon (1.00 g)?

**Solution:** We observe the ratio of small whole numbers by dividing the masses of oxygen by the smallest of the two. i.e., by 1.33

$$\text{In CO (1.33 g)} = 1.33/1.33 = 1; \text{ and in CO}_2 \text{ (2.66 g)} = 2.66/1.33 = 2$$

Therefore, the ratio of the masses of oxygen in CO and CO<sub>2</sub> is 1:2, which is a small whole number. This is consistent with the atomic theory if we consider that CO contains one atom of carbon and one atom of oxygen whereas CO<sub>2</sub> contains one atom of carbon and two atoms of oxygen. Since carbon dioxide has twice as many oxygen atoms bound to a carbon atom as does carbon monoxide, the weight of oxygen in a molecule of carbon dioxide must be twice the weight of oxygen in a molecule of carbon monoxide (**Figure 3.4**).



**Figure 3.4** The law of Multiple Proportion in  $\text{CO}$  and  $\text{CO}_2$ .

**Example 3.4:** Nitrogen forms seven different compounds with oxygen. In one of its compounds, it is observed that 2.62 g of nitrogen are combined with 1.50 g of oxygen while in another, 0.656 g of nitrogen are combined with 1.50 g of oxygen. Show that these data demonstrate the Law of Multiple Proportions.

**Solution:**

In both cases, we are dealing with a mass of nitrogen that combines with 1.50 g of oxygen. If these data are in agreement with the Law of Multiple Proportions, the ratio of the masses of nitrogen in the two compounds should be a ratio of small whole numbers. Let us, therefore, take the ratio  $2.62/0.656$ ; dividing the numerator and denominator by 0.656, we get 4:1, which is, indeed, a ratio of small whole numbers.



**Exercise 3.5**

Calculate

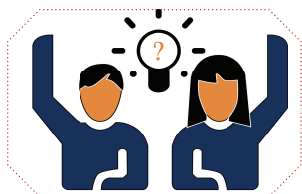
1. The ratio of the elements in one mole of  $\text{H}_2\text{O}_2$  and  $\text{H}_2\text{O}$ . Your teacher will provide you with a scheme that will help you answer this question.
2. The ratio of molar masses of  $\text{N}:\text{O}$ ;
3. The mass of oxygen combining with 1 g of nitrogen;
4. The small whole number ratio of oxygen combining with 1 g of nitrogen for  $\text{NO}$ ,  $\text{NO}_2$ ,  $\text{N}_2\text{O}$ ,  $\text{N}_2\text{O}_4$ ,  $\text{N}_2\text{O}_5$ . Your teacher will provide you with a table that will help you answer questions 2 to 4.

### 3.3 Atomic Theory

A **scientific theory** is an explanation of an aspect of the natural world and universe that can be repeatedly tested and verified by the scientific method, using accepted protocols of observation, measurement, and evaluation of results. The word ‘**theory**’ refers to the way how we interpret facts. **Atomic Theory** is, therefore, the way how we interpret facts about atoms. In this section we are going to discuss the historical development of atomic theory.

### 3.3.1 Dalton's Atomic Theory

At the end of this section, you will be able to describe Dalton's Atomic Theory.

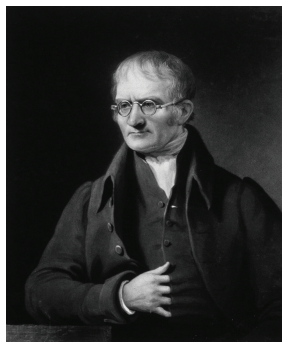


#### Activity 3.5

Students, form groups and discuss the following questions. Present your discussion points to the class.

1. Assume that you have a friend that doesn't know orange. How do you describe an orange for your friend?
2. Describe why an orange has basically two distinct colors.
3. Give a title for what you have done so far about orange.

Under section 3.1, we have discussed the concept that atoms are the fundamental building blocks of matter, and it dates back to very ancient times. The ideas regarding atoms of those times, however, had no experimental evidence and continued as mere speculation. These ideas, therefore, had to lay latent for a long period until the English man, John Dalton (**Figure 3.5**) proposed his atomic theory around 1803, based on certain observations and experimental results.



**Figure 3.5** John Dalton, an English chemist, meteorologist and physicist.

Democritus, many more scientists, philosophers, and others studied the composition of matter. A major leap forward in our understanding of the composition of matter took place in the 1800s with the work of the British scientist, John Dalton.

Dalton studied the weights of various elements and compounds. He perceived that matter is always combined in fixed ratios based on weight or volume in the case of gases. Chemical compounds always contain the same proportion of elements by mass, regardless of amount. This provided further support for Proust's Law of Definite Proportions. Dalton also observed that there could be more than one combination of two elements.

From his experiments and observations, as well as the work from peers of his time, Dalton proposed a new theory of the atom. This later became known as Dalton's Atomic Theory.



### Exercise 3.6

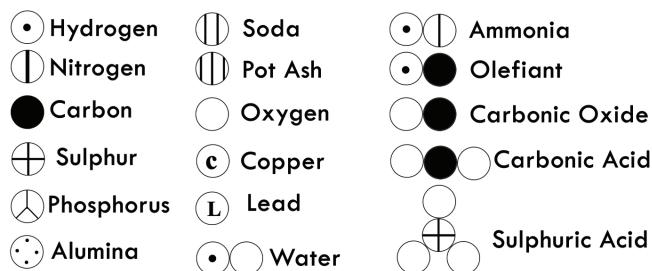
Provide the correct answer for the following questions.

1. What is the difference between Democritus and Dalton in terms of discovering an atom?
2. State the five tenets of Dalton's Atomic Theory.
3. What led Dalton to his atomic theory?

### Merits of Dalton's Atomic Theory

- ☞ The atomic theory explains the laws of chemical combination (the Law of Conservation of Mass and the Law of Multiple Proportions).
- ☞ Dalton was the first person to recognize a workable distinction between the fundamental particle of an element (atom) and that of a compound (molecule).

Dalton's effort was not limited to formulating atomic theory, but he proposed symbols for elements and compounds (**Figure 3.6**). The symbols of elements proposed by Dalton, however, were difficult to remember and draw. Therefore, an alternative method of representing elements was proposed by Berzelius. He suggested alphabets could be used as symbols to represent elements.



**Figure 3.6** Dalton's 1808 AD symbols and formulae.



### Exercise 3.7

Provide the correct answer for the following questions.

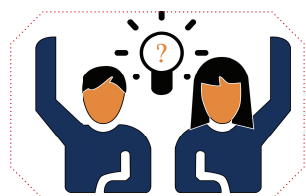
1. What are the successes of Dalton's Atomic Theory?
2. Dalton thought that atoms are the smallest particles of matter. Scientists now know that atoms are composed of even smaller particles. Does this mean that the rest of Dalton's Atomic Theory should be thrown away?



### 3.3.2 Modern Atomic Theory

At the end of this section, you will be able to

- ☞ describe the Modern Atomic Theory
- ☞ compare and contrast Dalton's Atomic Theory and the Modern Atomic Theory.



#### Activity 3.6

Students, form groups and discuss the following questions. Present your discussion points to the rest of the class.

1. Are you satisfied with the Greeks proposal of the origin of matter? Why?
2. What do you suggest if you were asked to tell someone about the smallest substance from which matter is made up of? What are its components known as?
3. In your grade 8 chemistry lessons, you were learned about the subatomic particles. Did you know who and how they were discovered?

The ancient Greeks proposed that matter consists of extremely small particles called atoms. Dalton postulated that each element has a characteristic type of atom that differs in properties from atoms of all other elements. Although the attempt made to describe the concept atom was good atoms were wrongly understood. Several other scientists were engaged in determining the essence of atoms and a better understanding of atoms was reached. The Modern Atomic theory establishes the concepts of atoms, and how they compose matter.

#### Development of the Modern Atomic Theory

Several scientists worked many experiments and have made various observations on atoms. The chronological discoveries of some of them are presented hereunder.

- ☞ The presence of protons was predicted by Eugene Goldstein in his anode ray experiment, in 1886.
- ☞ The first person who discovered the electron as a sub-atomic particle and its charge to mass ratio was the British physicist, J.J. Thomson, in 1897.
- ☞ Following this in 1904, Thomson developed the 'Plum pudding' model of the atom.
- ☞ Subsequently, in 1909, the American scientist; Robert Millikan found the charge and mass of the electron.
- ☞ The British physicist, Ernest Rutherford and his students Geiger and Marsden discovered the planetary model of an atom, in 1911.
- ☞ In 1913, Niels Bohr, a student of Rutherford's, proposed that electrons are arranged in concentric circular orbits around the nucleus.

## Chemistry Grade 9

- ☞ Subsequently, in 1920, Rutherford discovered the existence of the proton in the nucleus.
- ☞ In 1932, James Chadwick discovered the neutron which is another sub-atomic particle.

The detailed discussions of all the aforementioned discoveries of the sub-atomic particles are presented in section 3.4, below. All of these discoveries proved Dalton's Atomic Model wrong by revealing the following facts about atom.

### Drawbacks of Dalton's Atomic Theory

- ☞ The indivisibility of an atom was proved wrong: an atom can be further subdivided into protons, neutrons, and electrons. However, an atom is the smallest particle that takes part in chemical reactions.
- ☞ According to Dalton, the atoms of the same element are similar in all respects. However, atoms of some elements vary in their masses and densities. These atoms of different masses are called isotopes. For example, chlorine has two isotopes with mass numbers 35 and 37.
- ☞ Atoms of different elements differ in mass. This has been proven wrong in certain cases: argon and calcium atoms each have an atomic mass of 40 amu. These atoms are known as isobars.
- ☞ According to Dalton, atoms of different elements combine in simple whole-number ratios to form compounds. This is not observed in complex organic compounds like sugar ( $C_{12}H_{22}O_{11}$ ) and protein molecules.

The discoveries of the above facts about atoms led to the modified Modern Atomic Theory postulates.

### Modern Atomic Theory Postulates

- Elements are made of small particles called atoms.
- Atoms cannot be created or destroyed during ordinary chemical reactions.
- All atoms of the same element have the same atomic number but may vary in mass number due to the presence of different isotopes.
- Atoms of different elements are different.
- Atoms combine in small whole numbers to form compounds.



### Exercise 3.8

Provide the correct answer for the following questions.

- Compare and contrast Dalton's Atomic theory with Modern Atomic Theory.
- State the postulates of Modern Atomic Theory.
- Near the end of the 18<sup>th</sup> century, the first atomic theory was developed. Which of the following was not part of that early understanding?

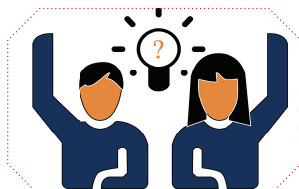
- a. All matter is made up of atoms.
  - b. Elements are composed of only one type of atom.
  - c. Atoms can combine with other atoms to make more complex substances.
  - d. Electrons orbit the nucleus in electron clouds.
  - e. All of above concepts were understood in the 18<sup>th</sup> century.
4. What are the drawbacks of Dalton's Atomic Theory, in your own words?

## 3.4 Discoveries of the Fundamental Subatomic Particles and the Atomic Nucleus

Following Dalton's Atomic Theory, several scientists investigated the nature of substances. More specifically, the nature of the atom. This section deals with the discoveries of the sub-atomic particles known as electrons, protons, neutrons, and the nucleus.

### 3.4.1 Discovery of the Proton

At the end of this section, you will be able to explain the discovery of protons.



#### Activity 3.7

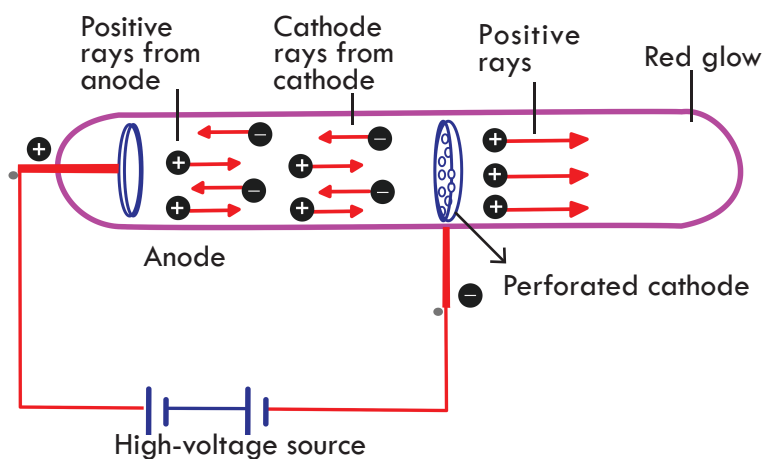
Students, form groups and discuss the following questions. Present your discussion points to the class.

1. What will happen to two objects having the same charge, if you bring them together?
2. According to Thomson electrons are negatively charged particles contained by an atom. Based on your answer for question one what do you expect to happen to these electrons?
3. What held these electrons from flying away from the atom?

The presence of positively charged particles in an atom has been predicted by Goldstein (1886) based on the electrical neutrality of an atom. The discovery of the proton by Goldstein was done based on the cathode ray experiment conducted by using a perforated cathode (**Figure 3.7**). In his experiment some rays were found to emanate from an anode and pass through the perforations in the cathode, without deflection by the cathode. These are called **anode rays** or **canal rays**.

Now days we understand Goldstein's experiment as follows. When an electric discharge is passed through the gas, some of the molecules of the gas ionised and produce cathode rays. Cathode rays consist of electrons. These electrons move with high speed towards the anode. As they move, they collide with the remaining molecules of the gas in the tube causing them to lose electrons resulting in positive ions. The

positive ions formed are attracted by the perforated cathode. The stream of these positive ions causes a glow on the glass wall of the discharge tube. On the other side of the discharge tube, the cathode rays produce a green light. The stream of positive ions so formed constitutes the positive or **anode rays**.



**Figure 3.7** Anode rays traveling through perforations in the cathode resulting in red glow on the cathode ray tube.

When the cathode ray tube contained hydrogen gas, the particles of the canal rays obtained were the lightest and their charge to mass ratio ( $e/m$  ratio) was the highest. Rutherford showed that these particles were identical to the hydrogen ion (hydrogen atom from which one electron has been removed). Due to this fact these particles were named as protons and were shown to be present in all matter. This is the first leap towards the discovery of the positively charged proton as part of the atomic structure. Today we know that the only positively charged species in an atom is the proton.

### Properties of anode rays:

- Anode rays travel in straight lines.
- They consisted of material particles.
- They are deflected in electric and magnetic field in opposite to that of cathode rays.
- The nature or  $e/m$  ratio of anode rays depends upon the nature of gas present in the cathode ray tube.
- They are (particles of anode rays) simply positively charged gaseous ions.



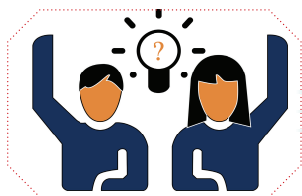
### Exercise 3.9

Provide the correct answer for the following questions.

- Define anode rays or canal rays.
- What is the other name of anode rays?
- Mention the properties of anode rays.

### 3.4.2 Discovery of the Electron

At the end of this section, you will be able to explain the discovery of electron.



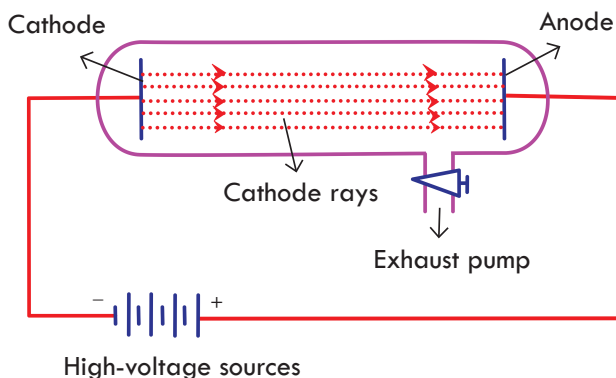
#### Activity 3.8

Students form groups and discuss the following questions. Present your discussion points to the class.

1. What happens to the electric bulb when you turn on the switch in your home?
2. What do you think happened inside the bulb?
3. Why do some electric bulbs give yellowish light and others white light?

#### The Crooke's Discharge Tube or Cathode Ray Tube

In 1855, the German inventor Heinrich Geissler developed the mercury pump and produced the first good vacuum tubes. These tubes, as modified by Sir William Crookes, became the first to produce cathode rays, leading eventually to the discovery of the electron. Sir William Crookes was the first scientist who designed the discharge tube which was called the **Crooke's Discharge Tube or Cathode Ray Tube**. The discharge tube consists of a glass tube from which most of the air has been evacuated having two metal plates sealed at both ends. These metal plates are called **electrodes**. These electrodes are connected to positive and negative terminals of a battery. The electrode connected to the positive terminal is known as **anode** and the **electrode** connected to the negative terminal is known as cathode (**Figure 3.8**).



**Figure 3.8** The Crooke's Discharge Tube or Cathode Ray Tube.

The electrodes are connected to high voltage for the current to flow. The high voltage provides energy for the atoms of a gas to further split or break up. When both electrodes are connected to high voltage, current starts flowing. At high pressure no electricity flows through the air in the discharge tube, so low pressure is used. Low pressure helps in conduction of electricity. At high voltage of 10,000 volts and at normal atmospheric pressure there is no effect. But keeping the same voltage if

## Chemistry Grade 9

pressure is reduced to 0.01 mm of Hg, a greenish glow was observed at anode. The rays are emitted from the direction of the cathode, and are called **cathode rays**. A good example of a cathode ray would be a **fluorescent bulb** in your home (**Figure 3.9**).

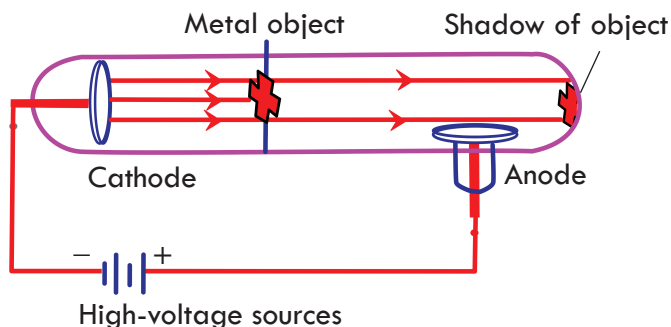


**Figure 3.9** Compact fluorescent lamps.

The electron was one of the fundamental subatomic particle that was discovered by the British physicist, J.J. Thomson, in 1897. In the discovery of electrons J. J. Thomson performed several experiments which are presented below.

### Thomson's Experiment on the Path of Cathode Rays

J. J. Thomson conducted some experiments with a discharge tube for studying the properties of cathode rays. The first experiment he has done is studying how cathode rays travel in the discharge tube by placing a small object between the cathode and the anode. The formation of a shadow of the object on the opposite side of the cathode revealed that the cathode rays travel in straight lines. The cathode rays travel towards the node because they are attracted by the positively charged anode. When an object is placed opposite to the direction of the cathode rays, a sharp shadow having the shape of the object is formed on the surface of the discharge tube glass. This concludes that cathode rays travel in straight lines (**Figure 3.10**).

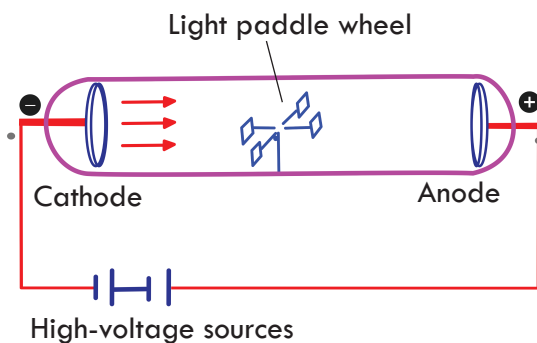


**Figure 3.10** Cathode rays creating a shadow of small object on the cathode ray tube screen.

### Thomson's Experiment on the Particle Nature of the Cathode Rays

J. J. Thomson's second experiment was performed by placing a light paddle wheel

between cathode and anode to study the particulate nature of the cathode rays (**Figure 3.11**). He expected to see if the cathode rays could move the paddle wheel. If they do so, then they have a particle nature. He observed the rotation of the light paddle wheel which revealed that the cathode rays are small particles having mass and kinetic energy.



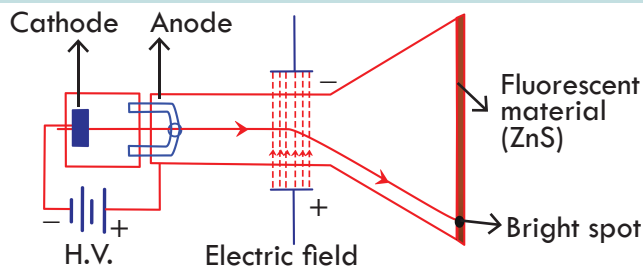
**Figure 3.11** Cathode rays rotating light paddle wheel between cathode and anode.

When cathode rays are allowed to fall on a paddle wheel, it rotates. This is possible only when the rays striking it have some material particles. From this, it can be concluded that cathode rays consist of some material particles. Today we know that the electron has both particle and wave nature (the wave nature of electrons will be discussed in grade 11). Its weight, however, is too small compared to the other subatomic particles. Therefore Thomson's contribution to the modern atomic structure is significant in this regard.

### Thomson's Experiment on the Charge of the Cathode Ray

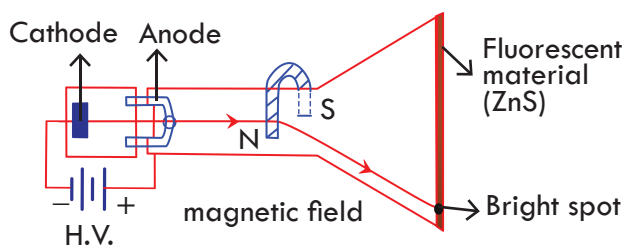
William Crookes experimented with cathode rays and magnets for the first time. His observations on the deflection of the rays by magnetic fields led him to conclude that they were composed of negatively charged molecules. Years later J. J. Thomson determined the molecules hypothesized by Crookes were actually negatively charged subatomic particles that he called corpuscles, but which were eventually named **electrons**.

J. J. Thomson performed the third experiment to investigate the charge of the cathode ray by passing cathode rays through electric and magnetic fields (**Figures 3.12 & 3.13**). Upon passing through an electric field, the cathode rays bent towards the positive plate. This proved that cathode rays are negatively charged particles. Thomson concluded that the particles had a net negative charge; these particles are now called **electrons**. We know from our knowledge of electricity, in physics, when an electric field is applied perpendicularly to the path of a negatively charged species, they deflect towards positive plate. As opposite charges attract, the cathode ray particles are negatively charged. Today we know that the only negatively charged fundamental particle of an atom is the electron. JJ Thomson's contribution is immense in this regard.



**Figure 3.12** Cathode rays bend passing through electric field.

Passing cathode rays through magnetic field applied perpendicular to the path of the cathode rays (**Figure 3.13**). This resulted in the deflection of the cathode rays perpendicular to the applied magnetic field. From our electromagnetism lessons, in physics, we know that a moving electric charge generates a magnetic field. A magnetic field induces electric charge movement, producing an electric current. In an electromagnetic wave, the electric field and magnetic field are perpendicular to one another. When the magnetic field is applied perpendicularly to the path of cathode rays, they get deflected towards the north pole of the magnet which is expected of negatively charged particles. This further confirms that cathode rays are negatively charged.



**Figure 3.13** Cathode rays bend passing through a magnetic field.

Thomson carried out the above experiments with different gases, at low pressure to decrease the interaction between gas molecules, in the discharge tube. No change in the properties of the cathode rays was observed despite the use of different gases in the discharge tube.

J. J. Thomson proved that atoms were not the most basic form of matter. He demonstrated that cathode rays could move a paddle wheel placed between two electrodes, could be deflected, or bent, by magnetic or electric fields, which indicated that cathode rays consist of charged particles. More important, by measuring the extent of the deflection of the cathode rays in magnetic or electric fields of various strengths, Thomson was able to calculate the mass-to-charge ratio of the particles to be  $1.76 \times 10^8$  C/g. These particles were emitted by the negatively charged cathode and repelled by the negative terminal of an electric field. Because like charges repel each other and opposite charges attract, Thomson concluded that the particles had a net negative charge; these particles are now called electrons.



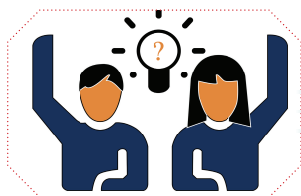


### Exercise 3.10

Provide the correct answer for the following questions.

1. Why was the ray bended? Shadow seen? The paddle rotated?
2. Why did Thomson take gas at low pressure while conducting the experiments?
3. How did Thomson discover the particle nature of electrons?
4. What happened to the cathode rays when they were allowed to pass through electric and magnetic fields? What does this prove?

### J. J. Thomson's Atomic Model



#### Activity 3.9

Students, form a group and discuss the following questions. Present your discussion points to the class.

1. What is your understanding about atomic model?
2. According to Democritus, what would an atom look like?
3. What do you expect Dalton's Atomic Model to be like, based on his experimental findings?

Following the discovery of the electron, J.J. Thomson developed what became known as the 'plum pudding' model in 1904 (**Figure 3.14**). *Plum pudding* is an English dessert similar to a blueberry muffin. In Thomson's plum pudding model of the atom, the electrons were embedded in a uniform sphere of positive charge like blueberries stuck into a muffin. The positive matter was thought to be jelly-like or similar to a thick soup. The electrons were somewhat mobile. As they got closer to the outer portion of the atom, the positive charge in the region was greater than the neighbouring negative charges, and the electron would be pulled back more toward the centre region of the atom. The best example of locally available material for Thomson's Model is watermelon. The seeds of the watermelon would mimic the electrons, and the watery soft reddish part is the positively charged matter (**Figure 3.14**).



**Figure 3.14** J. J. Thomson's atomic model (left); the "plum pudding" model (centre); watermelon (right).

### Validity of Thomson's Atomic Model

Thomson's Atomic Model could successfully explain the electrical neutrality of an atom. It, however, failed to explain how the positively charged particles are shielded from the negatively charged electrons without getting neutralized. Today we know that the positively charged protons exist in the nucleus of an atom which of course is at the centre of the atomic structure and the electrons are revolving around them. Therefore, Thomson's prediction is not negligible although it lacks some knowledge.

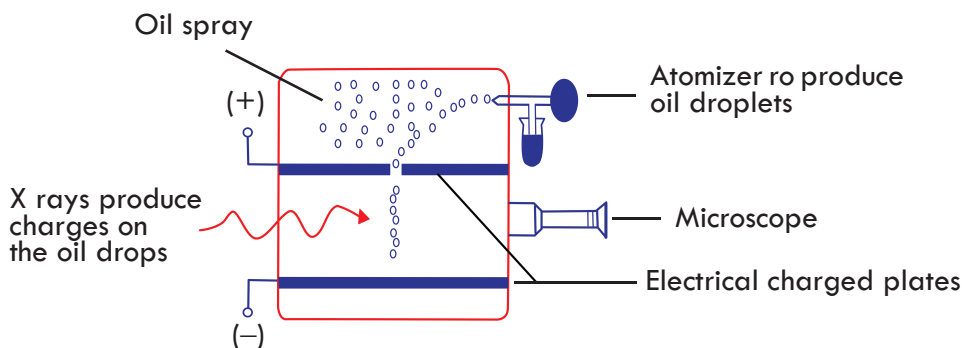
### Millikan's Oil Drop Experiment

Subsequently, an American scientist, Robert Millikan (1909) carried out a series of experiments using electrically charged oil droplets. In this experiment some fine oil droplets were allowed to be sprayed into the chamber by an atomizer. The air in the chamber is subjected to ionization by X-rays. The electrons produced by the ionization of air attach themselves to the oil drops. When a sufficient amount of electric field is applied, which can just balance the gravitational force acting on an oil drop, the drop remains suspended in the air.

From this experiment, Millikan observed that the smallest charge found on the cathode rays was approximately  $1.59 \times 10^{-19}$  coulombs, and the charge on each drop was always an integral multiple of that value. Based on this observation, he concluded that  $1.59 \times 10^{-19}$  coulomb is the smallest possible charge, and considered that value as the charge of the electron. With this information and Thomson's charge-to-mass ratio ( $1.76 \times 10^8 \text{C/g}$ ), Millikan determined the mass of an electron (**Figure 3.15**):

$$\text{Mass of electron} = \frac{e}{e/m}$$

$$\frac{1.59 \times 10^{-19} \text{C}}{1.76 \times 10^8 \text{C/g}} = 9 \times 10^{-28} \text{g}$$



**Figure 3.15** The apparatus used by Millikan to determine the charge of an electron.

From our understanding of electricity today, it is obvious that the force on any electric charge in an electric field is equal to the product of the charge and the electric field.

Millikan was able to measure both the amount of electric force and magnitude of electric field on the tiny charge of an isolated oil droplet. From this data he determined the magnitude of the charge itself.

### Summary of the properties of cathode rays:

- ☞ They travel in a straight line from the cathode and cast shadows of metallic objects placed in their path.
- ☞ They cause mechanical motion of small puddle-wheel placed in their path; they possess kinetic energy and must be material particles.
- ☞ Their properties are independent of the electrodes, and the gas present in the cathode ray tube.
- ☞ The charge/mass ratio of the rays is constant.
- ☞ Upon passing through electric field, the cathode rays bend towards the positive plate showing that they are negatively charged.
- ☞ Cathode rays are negatively charged and affected by magnetic field.
- ☞ Cathode rays affect ZnS screen. When cathode rays are allowed to strike ZnS screen, they produce a faint greenish fluorescence.
- ☞ Cathode rays ionises the gases. When cathode rays are allowed to pass through gases, different glows are seen in the tube. These different glows are due to the ionisation of gases.
- ☞ Cathode rays have penetrating power. When cathode rays are allowed to pass through thin metal foils, a glow is seen behind the metal foil indicating that they have good penetrating power.
- ☞ Cathode rays produce X-rays. When cathode rays are allowed to fall on metals such as tungsten, copper, X-rays are observed.



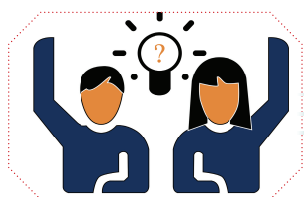
### Exercise 3.11

Provide the correct answer for the following questions.

1. Mass of the electron is calculated from \_\_\_\_\_ and \_\_\_\_\_ values of electron.
2. Describe Millikan's oil drop experiment in brief.
3. Describe J. J. Thomson's Atomic Model.
4. According to \_\_\_\_\_, the charges in an atom are arranged like the pulp and seeds of a watermelon.

### 3.4.3 Discovery of the Nucleus

At the end of this section, you will be able to explain the discovery of the nucleus.



### Activity 3.10

Students, form groups and discuss the following questions. Present your discussion points to the class.

1. From your grade 8 science lessons you know that the planets revolve around the Sun, in the Solar System. Assume that you have made a model of the Solar System from locally available materials by representing the planets and the Sun by stones. If you hang the model and throw a small stone towards it, is it always possible to hit the stones that represent the planets and the Sun? If your answer is no why? If your answer is yes how?
2. What do you think will happen to the probability of hitting the Sun if the number of stones you throw at the same time is 5? Does it increase or decrease? Why?
3. What will happen to those stones that hit the Sun in question three? What about those that did not hit the sun?

By 1920, with the discovery of electron and proton, it was thought that the inner structure of the atom was complete. The mass of the electron is negligible; hence the mass of atom should be equal to the mass of protons concentrated inside the nucleus. Different atoms have different number of protons, hence different atomic masses. However, it was observed that there was a discrepancy between the actual atomic mass and the calculated atomic mass.

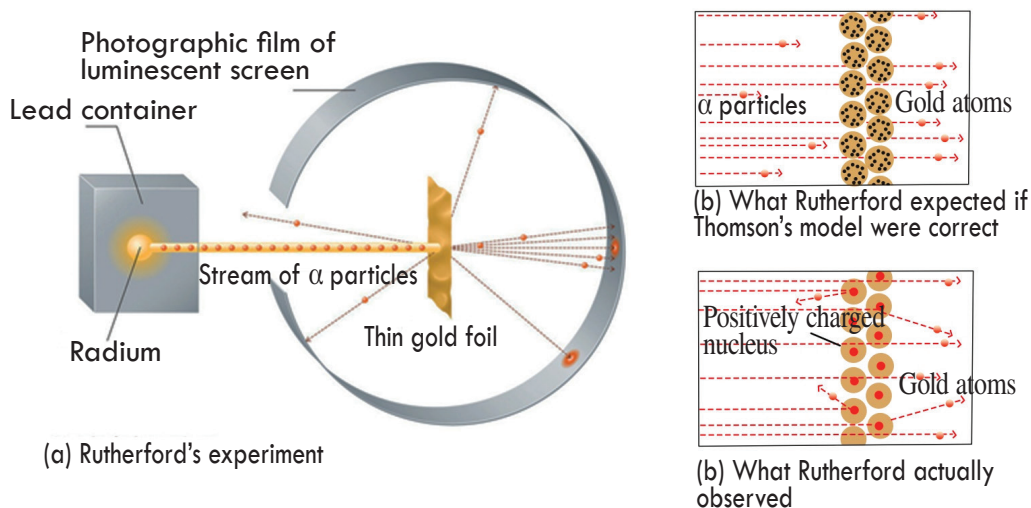
For example, an atom of carbon has 6 protons; therefore its mass should be six times the mass of hydrogen atom which has one proton. But, experimentally, it was found that the mass of carbon atoms is twelve times the mass of hydrogen atom. A similar problem was encountered with regard to the mass of other atoms. Then, what was the reason for this discrepancy?

Rutherford was the first scientist to predict the reason for this discrepancy. He predicted that along with protons, there were some other neutral particles present inside the nucleus. In a single famous experiment, the British physicist Ernest Rutherford showed explicitly that Thomson's model of the atom was incorrect. He used  $\alpha$ -particles in his experiment.  $\alpha$ -particles are composite particles consisting of two protons and two neutrons tightly bound together. In 1920, Rutherford targeted a stream of positively charged  $\alpha$  particles at a very thin gold foil target (**Figure 3.17a**) and inspected how the  $\alpha$  particles were scattered by the foil. The particles were produced by a sample of radium. Gold was chosen since it could be easily hammered into very thin sheets, minimizing the number of atoms in the target. If Thomson's model of the atom were correct, the positively charged  $\alpha$ -particles should smash through the regularly dispersed mass of the gold target like cannonballs (see **Figure 3.16**).



**Figure 3.16** A regularly distributed cannonballs.

They might be traveling a little slower when they appeared, but they should pass essentially straight through the target (**Figure 3.17b**). However, a small fraction of the  $\alpha$  particles were deflected at large angles, and some were reflected directly back at the source (**Figure 3.17c**).



**Figure 3.17** A Summary of Rutherford's Experiments.

Rutherford's results were not consistent with Dalton's atomic model in which the mass and positive charge are distributed uniformly throughout the volume of an atom. Instead, they strongly suggested that both the mass and positive charge are concentrated in a tiny minute fraction of the volume of an atom, which Rutherford called the **nucleus**. It made sense that a small fraction of the  $\alpha$  particles collided bumped with the dense, positively charged nuclei. This resulted in large deflections, or almost head-on, causing them to be reflected straight back at the source.

Rutherford's explanation for the stability of nucleus and atom: After the success of bringing out a successful atomic model, Rutherford was cornered by the other scientists by the question: "Why does the nucleus not disintegrate in spite of repulsion among the protons?" To explain the stability of the nucleus, Rutherford predicted the presence of neutral particles. The presence of these neutrons between the protons neutralises

## Chemistry Grade 9

the repulsion among the protons. Rutherford predicted the presence of the neutron even before it was discovered, which he proved it later on.

Coming to the stability of the atom, he explained that the revolving electron is under the influence of two types of forces.

- i. The electrostatic force of attraction between the nucleus and the electron and
- ii. The centrifugal force directed away from the revolving electron.

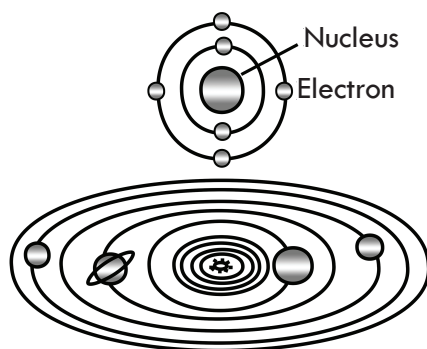
These two forces are equal and opposite and hence keep the electron in equilibrium in the path. This is the reason why electrons do not fall into the nucleus in spite of inward nuclear pull, according to Rutherford.

Today, it is known that strong nuclear forces, which are much stronger than electrostatic interactions, hold the protons and the neutrons together in the nucleus. For this and other insights, Rutherford was awarded the Nobel Prize in Chemistry in 1908.

### Rutherford's Atomic Model

The atom is mostly composed of empty space. The whole positive charge and mass of the atom are concentrated in a small central part known as the nucleus. The size of the nucleus is so small that its diameter is  $10^5$  times less than that of an atom. The diameter of the nucleus has been estimated by Rutherford as  $10^{-13}$  cm in contrast to that of an atom to be  $10^{-8}$  cm. The electrons existing outside the nucleus rotate around the nucleus with high .

Velocities to counterbalance the electrostatic forces of attraction between protons and electrons. Rutherford's atomic model bear a resemblance to the planetary motion in the **solar system** (grade 8). Rutherford's model of an atom is, therefore, also called the **Planetary Model** (see **Figure 3.18**).



**Figure 3.18** Rutherford's Model of an Atom in contrast to the Planetary Model (left); the 'Nuclear Atom Model' (right).

Rutherford's Atomic Model also became known as the *nuclear model*. In the nuclear atom, the protons and neutrons, which contain nearly all of the mass of the atom, are situated in the nucleus at the centre of the atom. The electrons are dispersed around the nucleus and occupy most of the volume of the atom. It is worth stressing just how

small the nucleus is compared to the rest of the atom. If we could inflate an atom to be the size of a large professional football stadium, the nucleus would be about the size of a cat's eye.

Rutherford's Model proved to be a significant step towards a full understanding of the atom. It did not, however, fully address the nature of the electrons, and how they reside in the vast space around the nucleus. It was not until some years far ahead that a full understanding of the electron was realized. This proved to be the key to understanding the chemical properties of elements.

Rutherford's experiments discovered the following aspects of the nucleus:

- ☞ The nucleus of an atom is positively charged.
- ☞ Most of the mass of an atom is concentrated in the nucleus.
- ☞ There are large spaces within an atom.

### Legitimacy of Rutherford's Atomic Model

Rutherford's Atomic Model could wonderfully explain the presence of a positively charged nucleus and the presence of electrons outside the nucleus in an atom. The failure of Rutherford's theory, however, stemmed from two major objections:

- ☞ This model is inconsistent to the principle of classical electro-dynamics. According to this, any charged particle in circular motion releases energy uninterruptedly. The electron being a charged particle in circular motion loses energy. This should finally result in its curved path towards the nucleus and the atom should then collapse.
- ☞ The second major objection to Rutherford's model came from the pattern of atomic spectra. The detailed explanation of this would be dealt with in the syllabi in grade 11.



### Exercise 3.12

Provide the correct answer for the following questions.

1. Why is Rutherford's Model called the nuclear model?
2. Who discovered the protons? Based on what experiment was he able to discover these protons?
3. According to Rutherford's Atomic Model, where are the protons and electrons located in an atom?
4. What are the drawbacks of Rutherford's Atomic Model?
5. Describe Rutherford's Atomic Model.
6. If Rutherford's Atomic Model is correct, then the atom should collapse. Explain?

### The Niels Bohr Atomic Model

In 1913, a Danish scientist, Niels Bohr could overcome the limitation of Rutherford's

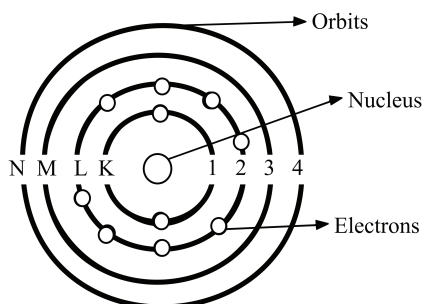


## Chemistry Grade 9

atomic model effectively based on the Quantum Theory of Radiation proposed by Max Planck. The concept of Quantum Theory is, however, beyond the scope of this subject. You will learn about it in grade 11. At this level, we will only present the principles associated with Bohr's Atomic Model.

Bohr, a student of Rutherford's, developed a new model of the atom. The Bohr Model can be summarized by the following five principles:

- ☞ Electrons are arranged in concentric circular orbits around the nucleus (see **Figure 3.19**).
- ☞ Electrons occupy only certain orbits around the nucleus. Those orbits are stable and are called '**stationary**' orbits or shells.
- ☞ Each orbit or shell is associated with a definite fixed amount of energy. Hence these are also called **energy levels** and are designated K, L, M, N respectively.
- ☞ The energy associated with a certain energy level increases with the increase of its distance from the nucleus. Hence if the energy associated with the K, L, M, N shells are  $E_1, E_2, E_3, \dots$ , etc. respectively, then  $E_1 < E_2 < E_3, \dots$ , etc.
- ☞ As long as the electron revolves in a particular orbit, the electron does not lose its energy.



**Figure 3.19** Neil Bohr's Atomic Model.



### Exercise 3.13

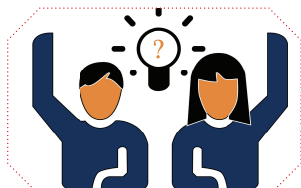
Provide the correct answer for the following questions.

1. Which model can be described as negatively charged electrons orbiting a positively charged nucleus in definite paths?
  - a. The Bohr Model.
  - b. The J.J. Thomson Model.
  - c. The Rutherford Model.
  - d. The Democritus Model.
  - e. The Leucippus Model.
2. The circular paths in which electrons revolve are called \_\_\_\_\_.
3. On what basis did Bohr propose his atomic model?
4. What are the orbits and why are they called stationary orbits?
5. Explain Bohr's Atomic Model.



### 3.4.4 Discovery of the Neutron

At the end of this section, you will be able to explain the discovery of neutron.

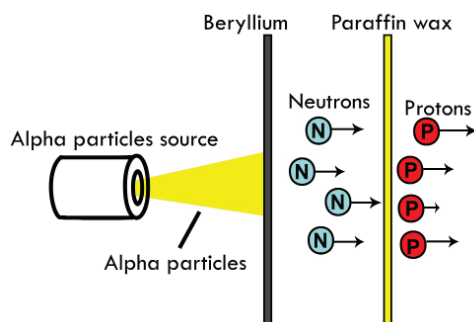


#### Activity 3.11

Students, form groups and discuss the following points. Present your discussion points to the class.

1. From your physics lessons you know that like charges repel each other. So, how do the positively charged protons exist in harmony in the tiny nucleus?

After the discovery of the proton, physicists had predicted that there were likely other particles in the atomic nucleus. This was seen from the fact that elements heavier than hydrogen had a larger atomic mass than their atomic number (the number of protons). Theories for the additional particles included additional protons whose charge was shielded by electrons in the nucleus or an unknown neutral particle. In 1932, French physicists, Frederic and Irene Joliot-Curie bombarded beryllium nuclei with  $\alpha$  particles and observed that unknown radiation was released that in turn ejected protons from the nuclei of various substances. Alpha particles, also called  $\alpha$  rays or  $\alpha$  radiation, consist of two protons and two neutrons bound together into a particle identical to a helium-4 nucleus. They are emitted from the nucleus of some radio nuclides (e.g., Polonium) during a form of radioactive decay, called  $\alpha$ -decay. The Joliot-Curies hypothesized that this radiation was  $\gamma$ -rays.



**Figure 3.20** James Chadwick's beryllium bombardment experiment.

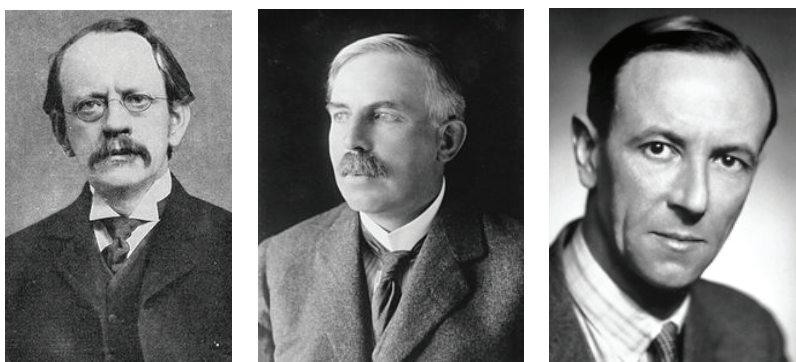
The English physicist, James Chadwick (**Figure 3.21**) was convinced that  $\alpha$  particles did not have sufficient energy to produce such powerful  $\gamma$ -rays. During an experiment it was found that, when  $\alpha$ -particles bombarded Beryllium nuclei, some radiations were observed. These radiations were found to be undeflected in an electric field. So, the earlier scientist thought these radiations could be  $\gamma$ -rays and hence discarded it. But Chadwick repeated the experiment and made the following observations.

- i. A paddle wheel was placed behind the Beryllium nucleus and the nucleus was bombarded with  $\alpha$ -particles. It was observed that the paddle wheel rotates. From

this, it was concluded that the beryllium nucleus emits some invisible radiations having material particles.

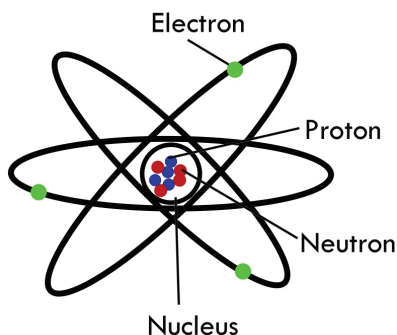
- ii. When these invisible radiations were allowed to pass through an electric field, there was no deviation seen. This confirmed the fact that these rays contained neutral particles. These neutral particles were called neutrons by James Chadwick.

That discovery provided a new tool for making atomic disintegration, since neutrons, being electrically uncharged, could enter undeflected into the atomic nucleus, and led to a new model of the atomic nucleus being composed of protons and neutrons (**Figure 3.22**). Neutrons could be captured by hydro-carbons or wax as shown in **Figure 3.20**.



**Figure 3.21** J.J. Thomson (left), Ernest Rutherford (centre), and James Chadwick (right).

The discovery of fundamental particles has ultimately resulted in the formation of a basic atomic model. The basic model of an atom encompasses a small positively charged nucleus (where protons and neutrons reside) at the centre of the atom and the electrons revolving around the nucleus in orbits.



**Figure 3.22** James Chadwick's Atomic Model.



### Exercise 3.14

Provide the correct answer for the following questions.

1. Who discovered the neutrons?
2. Neutrons were discovered by bombarding beryllium with \_\_\_\_\_.
3. Why the presence of the neutrons in an atom was predicted?
4. How were the neutrons discovered?

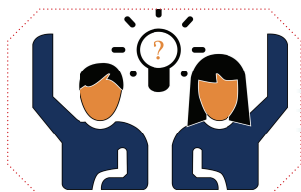
## 3.5 Composition of an Atom and the Isotopes

Atoms have different properties based on the arrangement and the number of their sub-atomic particles. Some elements have the same number of protons, but a different number of neutrons. This resulted in same elements having different masses, which in turn led to different properties. In this section, we are going to discuss about the electrons, the protons, and the neutrons in relation to the atomic structure, mass, and charge. We will also discuss about isotopes.

### 3.5.1 Electrons, Protons and Neutrons

At the end of this section, you will be able to

- ☞ Write the relative charges of an electron a proton and a neutron;
- ☞ Tell the absolute and relative masses of an electron, a proton and a neutron.



### Activity 3.12

Students, form groups and discuss the following questions. Present your discussion points to the class when asked by your teacher.

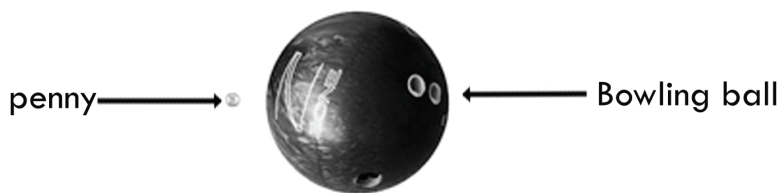
1. From your previous lessons you understood that the mass of proton and neutron is far exceeding the mass of an electron. What local materials can you give as an example that represents these three sub-atomic particles?
2. Can you describe how these three sub-atomic particles coexist in an atom, by considering their charge and mass?

### Electrons

Electrons are one of three fundamental particles that make up the atoms (**Figure 3.24**). Electrons are extremely small (**Figure 3.23**). The mass of an electron is only about  $1/2000$  the mass of a proton or a neutron, which is about  $0.00054897$  amu or  $9 \times 10^{-31}$  Kg. So, electrons contribute almost nothing to the total mass of an atom. The electric charge of an electron is  $-1$ , which is equal but opposite to the charge of a

## Chemistry Grade 9

proton. All atoms have identical number of electrons and protons, so the positive and negative charges ‘cancel out’ making atoms electrically neutral.



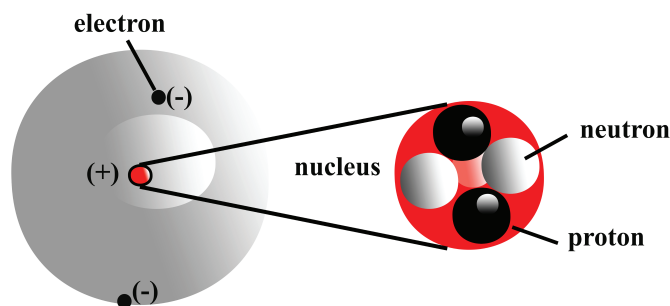
**Figure 3.23** Comparison of an electron (penny or cent) with proton (bowling ball).

### The Protons

The proton is one of the three sub-atomic particles that make up the atom. Protons are found in the nucleus of the atom (**Figure 3.24**). Proton is a tiny, compact region at the center of the atom. Protons have a positive electrical charge of one (+1) and a mass of 1.0073 atomic mass unit (amu), which is about  $1.67 \times 10^{-27}$  Kg. Together with neutrons, they make up virtually all of the mass of an atom.

### The Neutrons

Atoms of all elements apart from most atoms of hydrogen, have neutrons in their nucleus (**Figure 3.24**). Unlike the protons and the electrons, which are electrically charged, neutrons have no charge. That’s why the neutrons in **Table 3.1** are labeled  $n^0$ . The zero stands for ‘zero charge’. The mass of a neutron (1.0087 amu) is a little greater than the mass of a proton, which is 1 atomic mass unit (amu). An **atomic mass unit** equals about  $1.67 \times 10^{-27}$  Kg. A neutron also has about the same diameter as a proton, or  $1.7 \times 10^{-15}$  meters.



**Figure 3.24** The sub atomic particles.

**Table 3.1** Physical properties of sub atomic particles.

Particle	Symbol	Charge (coulombs)	Mass (Kg)	Relative charge	Mass (amu)	Location
Proton	$P^+$	$+1.59 \times 10^{-19}$	$1.673 \times 10^{-27}$	+1	1.0073	Inside the nucleus
Neutron	$n^0$	No charge	$1.675 \times 10^{-27}$	0	1.0087	Inside the nucleus
Electron	$e^-$	$-1.59 \times 10^{-19}$	$9 \times 10^{-31}$	-1	$5.4858 \times 10^{-4}$	Outside the nucleus



### Exercise 3.15

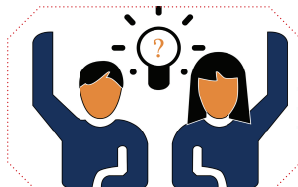
Provide the correct answer for the following questions.

1. Tell the mass and charge of the fundamental particles of an atom.
2. Compare the masses of protons and neutrons.
3. Compare the charges of electrons and protons.
4. Neutrons are neither attracted to nor repelled from the objects; they don't interact with protons or electrons. Explain?
5. Why is the mass of an atom depends only on the mass of protons and neutrons?

### 3.5.2 Atomic Number and Mass Number

At the end of this section, you will be able to

- ☞ tell the number of protons and electrons in an atom from the atomic number of the element
- ☞ determine the number of neutrons from given values of atomic numbers and mass numbers



#### Activity 3.13

Students, form groups and discuss the following questions. Present your discussion points to the class.

1. How do elements arrange in the periodic table?
2. In the previous section we have discussed about the masses of electrons, protons and neutrons. So, which particles account for the mass of an atom?
3. How is it possible to distinguish atoms of one element from atoms of another element?

It is important to be able to differentiate atoms of one element from atoms of another element. Elements are pure substances that make up all other matter, so each one is given a different name. From your grade 7 science lessons you know that the names of elements are represented by unique one- or two-letter symbols, such as H for hydrogen, C for carbon, or He for helium. However, it would be more authoritative if these names could be used to identify the numbers of protons and neutrons in the atoms. That's where atomic numbers and mass numbers are useful.

Scientists are always interested in atomic number and how it differs between different elements since an atom of one element can be distinguished from an atom of another element by the number of protons in its nucleus. The number of protons in an atom is called its **atomic number** ( $Z$ ). This number is very important because it is unique for

## Chemistry Grade 9

atoms of a given element. All atoms of an element have identical number of protons, and every element has a diverse number of protons in its atoms (**Table 3.2**). If an atom has only one proton, we know that it's a hydrogen atom. An atom with two protons is always a helium atom. If scientists count four protons in an atom, they know it's a beryllium atom. An atom with three protons is a lithium atom, an atom with five protons is a boron atom, an atom with six protons is a carbon atom . . . the list goes on.

**Table 3.2** Atoms of the first six elements.

Name	Protons	Neutrons	Electrons	Atomic Number (Z)	Mass Number (A)
Hydrogen	1	0	1	1	1
Helium	2	2	2	2	4
Lithium	3	4	3	3	7
Beryllium	4	5	4	4	9
Boron	5	6	5	5	11
Carbon	6	6	6	6	12

Of course, since neutral atoms have the same number of electrons to that of proton, an element's atomic number also tells you how many electrons are in a neutral atom of that element. Atoms are neutral in electrical charge because they have the same number of negative electrons as positive protons (**Table 3.2**). For example, hydrogen has an atomic number of 1. This means that an atom of hydrogen has one proton, and, if it's neutral, has one electron as well. Carbon, on the other hand, has an atomic number of 6, which means that an atom of carbon has 6 protons, and, if it's neutral, has 6 electrons as well.

### Mass Number

The mass number (A) of an atom is the total number of protons and neutrons in its nucleus. It is also known as the total number of nucleons in the atom's nucleus. Do not confuse atomic mass with mass number because it is the average weight of an element. Counting the number of protons and neutrons tells scientists about the total mass of an atom.

$$\text{Mass number } A = (\text{number of protons}) + (\text{number of neutrons})$$

An atom's mass number is very easy to calculate, provided that you know the number of protons and neutrons in an atom.

**Example 3.5:** What is the mass number of an atom of helium that contains 2 neutrons?

### Solution

(Number of protons) = 2 (Remember that an atom of helium always has 2 protons)

(Number of neutrons) = 2

Mass number = (number of protons) + (number of neutrons)

$$\text{Mass number} = 2 + 2 = 4$$

**Example 3.6:** How many protons, electrons, and neutrons are in an atom of K (mass number of 40)?

### Solution

Atomic number = (number of protons) = 19

For all atoms with no charge, the number of electrons is equal to the number of protons. Therefore, number of protons = number of electrons = 19

The mass number, 40, is the sum of the number of protons and the neutrons.

To find the number of neutrons, subtract the number of protons from the mass number.  
Number of neutrons =  $40 - 19 = 21$

**Example 3.7:** What is the atomic number, number of electrons, and neutrons in an atom of zinc having a mass number of 65 and 30 protons?

### Solution

Number of protons = Atomic number = 30

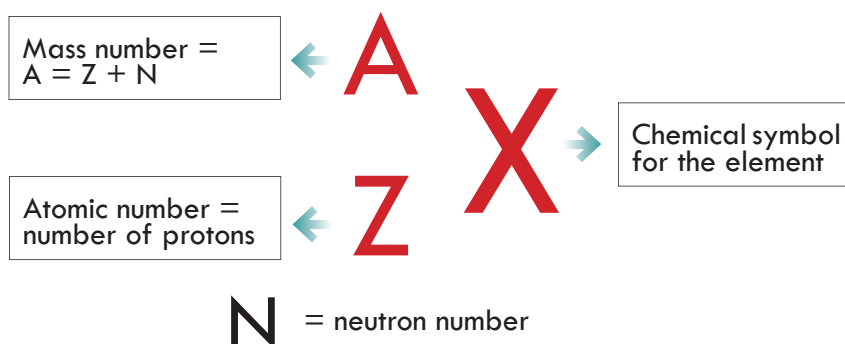
For all atoms with no charge, the number of electrons is equal to the number of protons. Number of protons = Number of electrons = 30

The mass number, 65, is the sum of the number of protons and the neutrons.

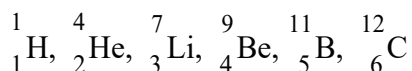
To find the number of neutrons, subtract the number of protons from the mass number.  
Number of neutrons =  $65 - 30 = 35$

### Representation of Mass Number and Atomic Number in a Nuclear Symbol of an Element

There is a common way in which scientists commonly express the mass number and the atomic number of an atom. To write a **nuclear symbol**, the mass number is placed at the upper left (superscript) of the chemical symbol, and the atomic number is placed at the lower left (subscript) of the symbol.



**Example 3.8:** The complete nuclear symbol for hydrogen mass number 1, helium mass number 4, lithium mass number 7, beryllium mass number 9, boron mass number 11 and carbon mass number 12 is given below:



In the carbon nucleus represented above, the atomic number 6 indicates that the nucleus contains 6 protons, and therefore, it must contain 6 neutrons to have a mass number of 12. The beryllium nucleus has 4 protons and 5 neutrons in order to have a mass of 9.



### Exercise 3.16

Provide the correct answer for the following questions.

- Which of the following pairs has almost similar masses?
  - Proton and electron
  - Neutron and electron
  - Electron and hydrogen (protium)
  - Neutron and hydrogen (protium)
- Aluminium has 13 protons and 14 neutrons. What is its mass number?
- Silicon's mass number is 28 and its atomic number is 14. What is its proton and neutron number?
- Chlorine has 18 neutrons and it has a mass number of 35. What is its proton number?
- Write the nuclear symbol of aluminium, silicon and chlorine.

### 3.5.3 Atomic Mass and Isotope

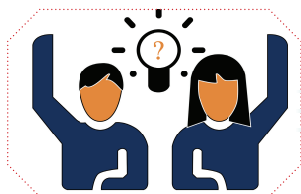
At the end of this section, you will be able to

- ☞ explain the terms atomic mass and isotope;
- ☞ calculate the atomic masses of elements that have isotopes.

Students, form groups and discuss the following questions. Present your discussion points to the class.

- In the drawbacks of Thomson's Atomic Theory, we have seen that atoms of the same element are not always alike. What was the reason for this?
- In the previous sections we have thoroughly discussed about the mass of an atom being concentrated in the nucleus. So how is it possible to get the atomic mass of an element?





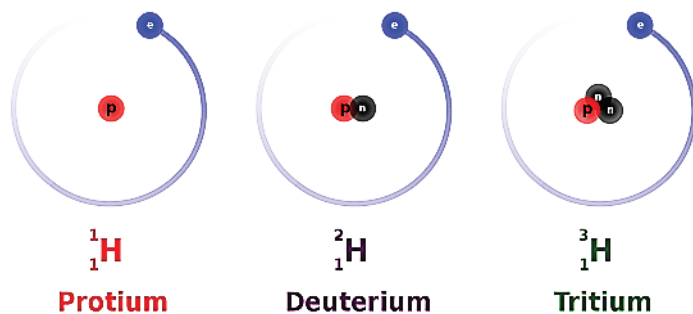
### Activity 3.14

3. Considering question number one above do you think the atomic mass of an element will always be the same? Why?
4. What is the difference between mass number and atomic mass of an element?

All atoms of the same element have the same number of protons, but some may have different numbers of neutrons. For example, all carbon atoms have six protons, and most have six neutrons as well. But some carbon atoms have seven or eight neutrons instead of the usual six. Atoms of the same element that differ in their numbers of neutrons are called **isotopes**. Many isotopes occur naturally. Usually, one or two isotopes of an element are the most stable and common. Different isotopes of an element generally have the same physical and chemical properties because they have the same numbers of protons and electrons.

#### Example 3.9: Hydrogen Isotopes

Hydrogen is an example of an element that has isotopes. Three isotopes of hydrogen are modelled in **Figure 3.25**. Most hydrogen atoms have just one proton, one electron, and lack a neutron. These atoms are just called **hydrogen**. Some hydrogen atoms have one neutron as well. These atoms are the isotope named **deuterium**. Other hydrogen atoms have two neutrons. These atoms are the isotope named **tritium**. They are also known as heavy hydrogen.



**Figure 3.25** The three most stable isotopes of hydrogen: protium ( $A = 1$ ), deuterium ( $A = 2$ ), and tritium ( $A = 3$ ).

For most elements other than hydrogen, isotopes are named for their mass number. For example, carbon atoms with the usual 6 neutrons have a mass number of 12 (6 protons + 6 neutrons = 12), so they are called carbon-12. Carbon atoms with 7 neutrons have an atomic mass of 13 (6 protons + 7 neutrons = 13). These atoms are the isotope called carbon-13.

### Stability of Isotopes

Atoms need a certain proportion of neutrons to protons to have a stable nucleus. Having too many or too few neutrons relative to protons, results in an unstable, or radioactive, nucleus that will sooner or later breakdown to a more stable form. This process is called radioactive decay. Many isotopes have **radioactive nuclei**, and these isotopes are referred to as **radioisotopes**. When they decay, they release particles that may be destructive. This is why radioactive isotopes are risky and why working with them requires special suits for protection. The isotope of carbon known as carbon-14 is an example of a radioisotope. In contrast, the carbon isotopes called **carbon-12 and carbon-13** are stable.

This whole discussion of isotopes brings us back to **Dalton's Atomic Theory**. According to Dalton, atoms of a given element are identical. But if atoms of a given element can have different numbers of neutrons, then they can have different masses as well. How did Dalton miss this? It turns out that elements found in nature exist as constant uniform mixtures of their naturally occurring isotopes. In other words, a piece of lithium metal always contains both types of naturally occurring lithium (the type with 3 neutrons and the type with 4 neutrons). Moreover, it always contains the two in the same relative abundance. In a lump of lithium, 93% will always be lithium with 4 neutrons, while the remaining 7% will always be lithium with 3 neutrons.

### Calculating mass number of isotopes

#### Problem 1: Lithium Isotopes

- What are the atomic number and the mass number of an isotope of lithium containing 3 neutrons?
- What are the atomic number and the mass number of an isotope of lithium containing 4 neutrons?

#### Solution

A lithium atom contains 3 protons in its nucleus irrespective of the number of neutrons or electrons.

- Atomic number = (number of protons) = 3  
(number of neutrons) = 3  
Mass number = (number of protons) + (number of neutrons)  
mass number = 3 + 3 = 6
- Atomic number = (number of protons) = 3  
(number of neutrons) = 4  
Mass number = (number of protons) + (number of neutrons)  
mass number = 3 + 4 = 7

Note that because the lithium atom always has 3 protons, the atomic number for lithium is always 3. The mass number, however, is 6 in the isotope with 3 neutrons, and 7 in the isotope with 4 neutrons. Naturally, only certain isotopes exist. For instance, lithium exists as an isotope with 3 neutrons, and as an isotope with 4 neutrons, but it

doesn't exist as an isotope with 2 neutrons, or as an isotope with 5 neutrons.

### Atomic Mass

Masses of separate atoms are very, very small. Using a modern device called a **mass spectrometer**; it is possible to measure such tiny masses. An atom of oxygen-16, for example, has a mass of  $2.66 \times 10^{-23}$  g. While comparisons of masses measured in grams would have some utility, it is far more practical to have a system that will permit us to more easily compare relative atomic masses. Scientists decided on using the carbon-12 nuclide as the reference standard by which all other masses would be compared. By definition, one atom of carbon-12 is assigned a mass of 12 **atomic mass units** (amu). An atomic mass unit is defined as a mass equal to one-twelfth the mass of an atom of carbon-12 or  $1.992646547 \times 10^{-23}$  g, which is assigned an atomic mass of 12 units. In this scale, 1 atomic mass unit (amu) corresponds to  $1.660539040 \times 10^{-24}$  g. The atomic mass unit is also called the **Dalton** (Da), after English chemist John Dalton. The mass of any isotope of any element is expressed in relation to the carbon-12 standard. For example, one atom of helium-4 has a mass of 4.0026 amu. An atom of sulfur-32 has a mass of 31.972 amu.

### Average Atomic Mass

Since many elements have some isotopes, chemists use average atomic mass. If we know the natural abundance and the mass of all the isotopes, we can find the average atomic mass. The **natural abundance of an isotope** of an element is the percent of that isotope as it occurs in a sample on earth. The **average atomic mass** is merely a weighted average of the masses of all the isotopes. We can calculate this by the following equation:

$$\text{Average Atomic Mass} = [(\% \text{ isotope 1})(\text{mass of isotope 1})] \div 100 + [(\% \text{ isotope 2})(\text{mass of isotope 2})] \div 100 + \dots$$

**Problem 2:** Find the average mass of lithium (Li-7, 93% and Li-6, 7%).

**Solution:** We follow the following calculation:

Lithium with 4 neutrons has a mass number of 7 and its percentage abundance is 93%.  
Lithium with 3 neutrons has a mass number of 6 and its percentage abundance is 7%.

$$\begin{aligned} \text{Average mass of lithium} &= (7 \times 93) \div 100 + (6 \times 7) \div 100 \\ &= 6.51 + 0.42 = 6.93 \end{aligned}$$

The average atomic mass of lithium is, therefore, 6.93 amu.

**Problem 3:** Boron has two naturally occurring isotopes. In a sample of boron, 20% of the atoms are B-10, which is an isotope of boron with 5 neutrons and a mass of 10 amu. The other 80% of the atoms are B-11, which is an isotope of boron with 6 neutrons and a mass of 11 amu. What is the atomic mass of boron?

## Chemistry Grade 9

Following the same approach as lithium, the average atomic mass of boron is:

$$\begin{aligned}\text{Atomic mass of boron} &= [(10 \times 20) \div 100] + [(11 \times 80) \div 100] \\ &= 2 + 8.8 \\ &= 10.8\end{aligned}$$

The average atomic mass is, therefore, 10.8 amu.

**Problem 4:** Neon has three naturally occurring isotopes. In a sample of neon, 90.92% of the atoms are Ne-20, which is an isotope of neon with 10 neutrons and a mass of 19.99 amu. Another 0.3% of the atoms are Ne-21, which is an isotope of neon with 11 neutrons and a mass of 20.99 amu. The remaining 8.85% of the atoms are Ne-22, which is an isotope of neon with 12 neutrons and a mass of 21.99 amu. What is the atomic mass of neon?

### Solution

Neon has three isotopes. We will use the equation:

$$\text{Atomic mass} = [(\% \text{ isotope 1}) (\text{mass of isotope 1})] \div 100 + [(\% \text{ isotope 2}) (\text{mass of isotope 2})] \div 100 + [(\% \text{ isotope 3}) (\text{mass of isotope 3})] \div 100$$

$$\begin{aligned}\% \text{ Isotope 1} &= 0.9092 \text{ (write all percentages as decimals), mass of isotope 1} \\ &= 19.99\end{aligned}$$

$$\% \text{ Isotope 2} = 0.003, \text{ mass of isotope 2} = 20.99$$

$$\% \text{ Isotope 3} = 0.0885, \text{ mass of isotope 3} = 21.99$$

Substituting these into the equation, and we get:

Atomic mass of neon =

$$= [(0.9092) (19.99)] \div 100 + [(0.003) (20.99)] \div 100 + [(0.0885) (21.99)] \div 100$$

$$= 20.17 \text{ amu}$$

The average atomic mass of neon atom is, therefore, 20.17 amu.

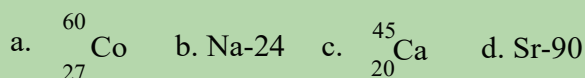
Dalton always experimented with large element-chunks that contained all of the naturally occurring isotopes of that element. As a result, when he performed his measurements, he was in fact perceiving the averaged properties of all the different isotopes in the sample. We will do the same thing for most of our purposes in chemistry, and deal with the average mass of the atoms. Fortunately, other than having different masses, most other properties of different isotopes are similar.



### Exercise 3.17

Provide the correct answer for the following questions.

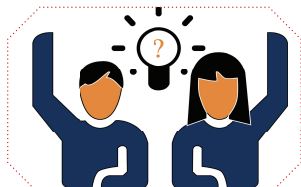
1. In an element that has isotopes, which of the sub -atomic particles are different, and which remain unchanged?
2. How many protons, electrons, and neutrons are there in each of the following atom?



3. Calculate the average atomic mass of copper: Cu-63, 69.15% & Cu- 5, 30.85%.
4. Calculate the average atomic mass of chlorine: Cl-35, 75% & Cl-37, 25%.

### 3.5.4 Main Energy Levels

At the end of this section, you will be able to describe main energy level.

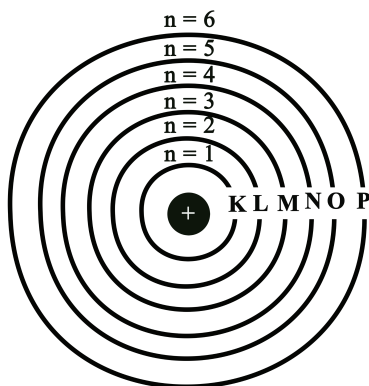


#### Activity 3.15

Students, form groups and discuss the following questions. Present your discussion points to the class.

1. Who discovered energy levels? What is the other name of energy levels?
2. In the Bohr's atomic model, why do electrons disperse themselves?
3. According to Bohr's atomic model, how do electrons arrange themselves?

The concept of orbits in which electrons revolve around the nucleus was proposed by a student of Rutherford named Niels Bohr in 1913. Refer the five principles of Bohr's atomic model discussed under section 3.4.3. Today, in chemistry, the principal energy level or the main energy level of an electron refers to the shell in which the electron is located relative to the atom's nucleus. This level is denoted by the principal quantum number  $n$ . The principal number could also be denoted by the whole numbers 1, 2, 3, 4, . . . or by the letters K, L, M, N, etc. (**Figure 3.26**)



**Figure 3.26** Main energy levels.

The energy of the orbit sometimes known as the shell increases upon moving away from the nucleus i.e., it follows the increasing order  $K < L < M < N$  or  $1 < 2 < 3 < 4$ , etc.



### Exercise 3.18

Provide the correct answer for the following questions.

1. What is the main energy level of an electron?
2. How many main energy levels does each of the first twenty elements (H to Ca) have?

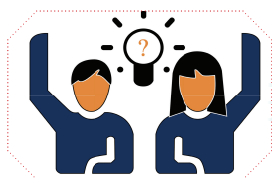
### 3.5.5 Electronic Configuration on Main Shells

At the end of this section, you will be able to

- ☞ define electronic configuration;
- ☞ write the ground state electronic configuration of the elements;
- ☞ draw diagrams to show the electronic configuration of the first 20 elements;
- ☞ write electronic configuration of the elements using noble gas as a core.

Students, form groups and discuss the following questions. Present your discussion points to the class.

1. In a certain class room, there are 2 seats in the first row, 8 seats in the second row, 18 seats in the third row, and 32 seats at the back of the room.



### Activity 3.16

If the rows with small seats are closer to the teacher i.e., 2, 18, 32 respectively and all students must sit beginning from the seats closer to the teacher, how will 35 students take seat?

- How would you arrange 20 electrons on an atom that can hold 2 electrons on K-shell, 8 electrons on L-shell, 18 electrons on M-shell, and 32 electrons on N-shell? (Hint begin arranging electrons from the lowest shell, in energy).

We picture an atom as a small nucleus surrounded by a much larger volume of space containing the electrons. This space is divided into regions called principal energy levels. Each principal energy level can contain up to  $2n^2$  electrons, where  $n$  is the number of the level ( $n = 1, 2, 3$ , etc.). Thus, the first level can contain up to 2 electrons,  $2(1^2) = 2$ ; the second up to 8 electrons,  $2(2^2) = 8$ ; the third up to 18,  $2(3^2) = 18$ , and so on. Only seven energy levels are needed to contain all the electrons in an atom of any of those elements known thus far. The systematic arrangement of electrons in the various shell or orbits in an atom is called **electronic configuration**.

The **electron configuration** of an element describes how electrons are distributed in their energy levels or shells. Electron configurations of atoms in the main energy levels follow a standard notation in which the number of electrons arranged in all electron-containing atomic shells is placed in a sequence. Filling energy levels with electrons begins from the lower in energy or the shell closer to the nucleus i.e., K shell and goes on sequentially to L, M, N, etc.

The last shell or the outermost shell from the nucleus with electrons is called the **valence shell**. The shell inner to this is called the **penultimate shell**, and the one inner to penultimate shell is called the **anti-penultimate shell**.

Shell	$2n^2$
K	2
L	8
M	18
N	32
O	50

The maximum number of electrons that can be filled in the valence shell is 8, that in the penultimate shell is 18, and the anti-penultimate shell has a maximum capacity of 32 electrons. The filling of electrons till atomic number 30 follows the following pattern.

K	L	M	N
2			
2	8		
2	8	8	
2	8	8	2
2	8	18	2

**Example 3.10:** The atomic number of calcium is 20. Write the electronic configuration of calcium.

**Solution:**

The first shell (K shell) can hold  $2(1^2) = 2$ ,

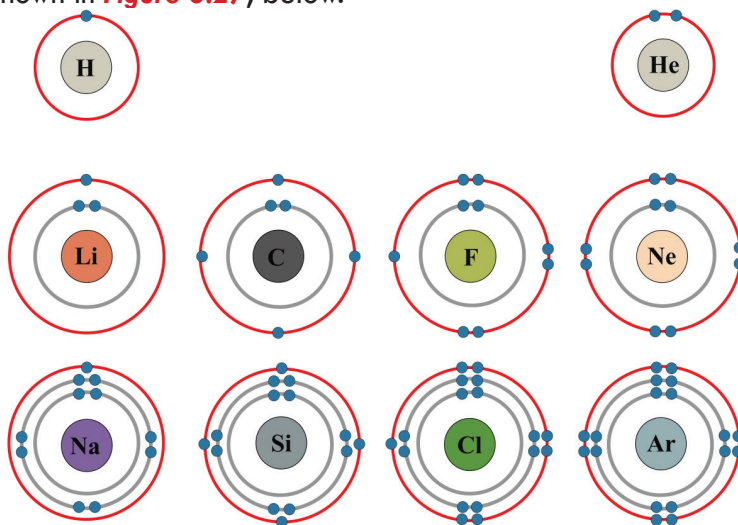
The second shell (L shell) can hold  $2(2^2) = 8$ ,

The third shell (M shell) can hold  $2(3^2) = 18$  but since calcium has only 20 electrons; the first two shells held 10 ( $2 + 8$ ) electrons. Hence the number of electrons left from these shells will be  $20 - 10 = 10$ . Therefore, the M shell is left with 10 electrons. However, according to the above rule the valence shell cannot hold more than 8 electrons. We can then write the electronic configuration of  $\text{Ca} = 2, 8, 8, 2$ .

**Example 3.11:** Write the electronic configuration of Argon (electrons 18).

Solution: Following the same procedure as calcium, the electronic configuration of argon will be:  $\text{Ar} = 2, 8, 8$ .

The electronic configuration of the elements could also be drawn using atomic diagrams. For example, the diagrammatic representation of the electronic configurations of some elements is shown in **Figure 3.27**, below.



**Figure 3.27** Electronic configuration of H, He, Li, C, F, Ne, Na, Si, Cl, and Ar using energy diagrams.



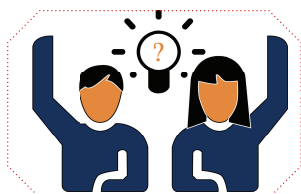


### Exercise 3.19

1. Define the term electronic configuration of an element.
2. Write the electronic configurations of the first 20 elements (H to Ca) in the periodic table.
3. Draw the electronic configuration of the first 20 elements (H to Ca) using the energy diagrams.

### 3.5.6 Valence Electrons

At the end of this section, you will be able to describe valence electrons.



#### Activity 3.17

Students, form groups and discuss the following questions. Present your discussion points to the class.

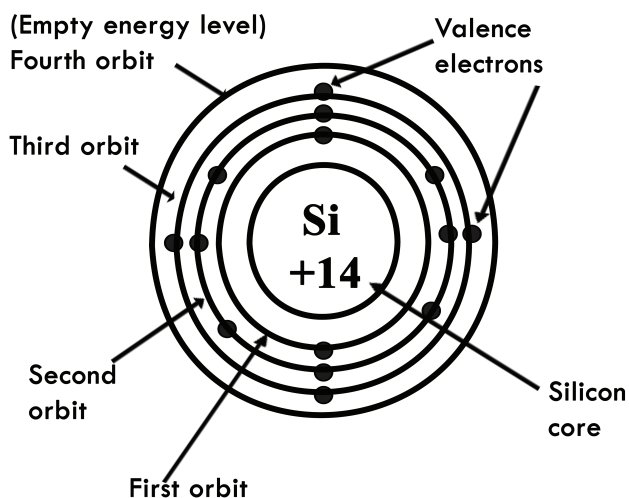
Given an atom X has atomic number 20, its electronic configuration is  $K=2, L=8, M=8$  and  $N=2$ . Which shell electrons are

1. Valence electron
2. Penultimate electrons and
3. Antipenultimate electrons?

As stated earlier, the energy related with an energy level increases as the distance from the nucleus increases. An electron in the seventh energy level has more energy associated with it than does one in the first energy level. The lesser the number of the principal energy level, the closer the electron in it is to the nucleus, and the more tough it is to remove this electron from the atom, due to strong electrostatic attraction.

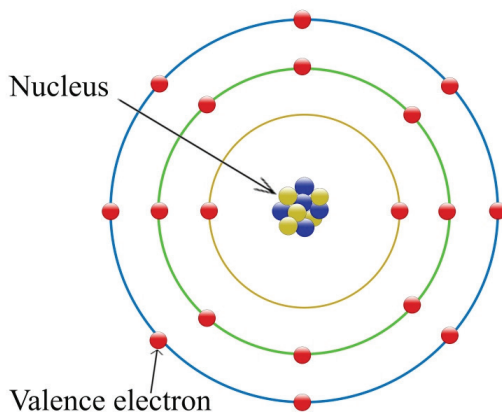
In section 3.5.5, we have discussed about writing the electronic configuration of elements. The electrons that occupy the outermost shell of an atom are called valence electrons. Valence electrons are furthest from the nucleus of the atom. They are the most easily lost, and the ones that determine the element's chemical properties, and how an atom will react. Atoms lose, gain, or share their valence electrons during chemical reactions. By writing an electronic configuration, you will be able to see how many electrons occupy the highest energy level.

**Example 3.12:** The electronic configuration of silicon (Si) is 2, 8, 4. The first two electrons occupy the inner shell (K shell), the next 8 electrons occupy the middle shell (L shell), and the remaining 4 electrons occupy the outermost shell (M shell) known as the valence shell (see **Figure 3.28**).



**Figure 3.28** An energy diagram showing the valence electrons of Silicon.

**Example 3.13:** The electronic configuration of argon (Ar) is 2, 8, 8. The valence shell of the argon atom is the M shell having 8 valence electrons (see **Figure 3.29**).



**Figure 3.29** An energy diagram showing the valence electrons of Argon atom.



### Exercise 3.20

Provide the correct answer for the following questions.

1. Define the term electronic configuration of an element.
2. Write the electronic configurations of the first 20 elements (H to Ca) in the periodic table.
3. Draw the electronic configuration of the first 20 elements (H to Ca) using the energy diagrams.

## Key Terms and Equations

☞ Atom	☞ $\alpha$ particle	decay
☞ Theory	☞ X-ray	☞ Radioisotopes
☞ Atomic Theory	☞ Canal rays	☞ Average atomic mass
☞ Chemical Law	☞ Perforated cathode	☞ Natural abundance
☞ Scientific Law	☞ Nuclear model	☞ Energy level
☞ Electron Proton	☞ Atomic model	☞ Shell
☞ Neutron	☞ $\alpha$ -Radiation	☞ Orbit
☞ Nucleus	☞ $\alpha$ -Decay	☞ Principal quantum number
☞ Cathode ray	☞ Isotope	☞ Electronic configuration
☞ Anode ray	☞ Atomic mass unit	☞ Valence shell
☞ $\gamma$ -ray	☞ Atomic mass	☞ Valence electron
☞ Discharge tube	☞ Mass number	☞ Penultimate shell
☞ Cathode-ray tube	☞ Atomic number	☞ Anti-penultimate shell
☞ Anode	☞ Protium	☞ Atomic diagram
☞ Cathode	☞ Deuterium	
☞ Fluorescent	☞ Tritium	
☞ Magnetic Field	☞ Radioactive	
☞ Electric field	☞ Radioactive	

Mass Number = (number of protons) + (number of neutrons)

Average Atomic Mass = [(% isotope 1)(mass of isotope 1)]  $\div$  100 + [(%isotope 2)(mass of isotope 2)]  $\div$  100 + . . .

## Unit Summary

In this unit we have discussed about how the atomic structure was proposed in conjunction with the discoveries of the atom and the fundamental subatomic particles known as protons, neutrons, electron and the nucleus. This then led us to the definitions of terms like atomic number, mass number, isotope, energy level, valence electrons, and electronic configuration of atoms. We have also discussed how to calculate the number of protons, electrons, and neutrons of atoms from atomic and mass numbers of atoms. We have discussed about the calculation of the atomic masses of elements that have isotopes. Finally we have briefly seen how to arrange electrons on the main energy levels of the atoms which is commonly known as the electronic configuration of atoms.

Atomic theory originated as a philosophical concept in ancient India and Greece. The word “atom” comes from the ancient Greek word *atomos*, which means indivisible. According to atomism, matter consists of discrete particles. However, the theory was one of many explanations for matter and wasn’t based on experiential data.

In the middle of the 5<sup>th</sup> century BC, an ancient Greek philosopher, *Empedocles*, thought

## Chemistry Grade 9

that all materials are made up of four things called elements: **earth, air, water, and fire**. **Plato**, student of Socrates and teacher of Aristotle, adopted Empedocles' Theory, and coined the term **element** to describe these four substances. His successor, **Aristotle**, also adopted the concept of four elements. The Greek philosophers' concept of four elements existed for more than two thousand years. There after Zeno of Elea came up with his paradoxical divisibility and indivisibility of matter. Zeno's indivisibility and divisibility of matter were later on changed by the concept of an '**atom**' by **Leucippus** and **Democritus**. In the 5<sup>th</sup> century BC, **Democritus** proposed that matter consists of indestructible, indivisible units called **atoms**. However, since **Aristotle** and other prominent thinkers of the time strongly opposed their idea of the atom, their theory was disregarded and essentially buried until the 16<sup>th</sup> and 17<sup>th</sup> centuries.

It took until the end of the 18<sup>th</sup> century for science to provide concrete evidence of the existence of atoms. In 1789, **Antoine Lavoisier** formulated the **Law of Conservation of Mass**, which states that *the mass of the products of a reaction is the same as the mass of the reactants*. Ten years later, Joseph Louis Proust proposed the Law of Definite Proportions, which states that the masses of elements in a compound always occur in the same proportion.

These theories didn't reference atoms, yet John Dalton built upon them to develop the Law of Multiple Proportions, which states that the ratios of masses of elements in a compound are small whole numbers. Dalton's Law of Multiple Proportions drew from experimental data. He proposed that each chemical element consists of a single type of atom that could not be destroyed by any chemical means. His work marked the beginning of the scientific atomic theory.

Up to this point, atoms were believed to be the smallest units of matter. In 1897, **J.J. Thomson** discovered the electron. Thomson also discovered the charge to mass ratio of the electron. He believed atoms could be divided. Because the electron carried a negative charge, he proposed a plum pudding model of the atom (1904), in which electrons were embedded in a mass of positive charge to yield an electrically neutral atom. Subsequently in 1909, the American scientist Robert Millikan found the charge and mass of the electron, in his oil drop experiment.

**Ernest Rutherford**, one of Thomson's students, disproved the plum pudding model in 1909. Rutherford found that the positive charge of an atom and most of its mass were at the center, or nucleus, of an atom. In 1911, Rutherford together with his students Geiger and Marsden described a **planetary model** in which electrons orbited a small, positive-charged nucleus.

Rutherford was on the right track, but his model couldn't explain why the electrons didn't crash into the nucleus. In 1913, **Niels Bohr** proposed the **Bohr model**, which states *that electrons only orbit the nucleus at specific distances from the nucleus*. According to his model, electrons couldn't spiral into the nucleus but could make quantum leaps between energy levels. Subsequently, in 1920, Rutherford discovered the existence

of the proton in the nucleus. In 1932, James Chadwick discovered the neutron which is another sub-atomic particle. His atomic model encompasses a small positively charged nucleus (where protons and neutrons reside) at the centre of the atom and the electrons revolving around the nucleus in orbits, which is the basic atomic model. The discoveries of the above facts about atoms led to the modified Modern Atomic Theory postulates. Modern Atomic Theory postulates:

- ☞ Atom is made up of the sub-atomic particles: protons, neutrons and electrons.
- ☞ Atoms of the same element may not be the same in all aspects, for example isotopes.
- ☞ Atoms of different elements may not be different in all aspects, for example isobars.
- ☞ The ratio in which atoms combined may not be simple.

The presence of positively charged particles in an atom has been predicted by Goldstein (1886) based on the electrical neutrality of an atom. The discovery of the **proton** by Goldstein was done based on the cathode ray experiment conducted by using a perforated cathode.

The electron was one of the fundamental subatomic particle that was discovered by the British physicist, J.J. Thomson, in 1897. In the discovery of electrons J. J. Thomson performed several experiments on the cathode rays.

- ☞ The first experiment he has studied was the straight line travel of cathode rays in the discharge tube by placing a small object between the cathode and the anode.
- ☞ J. J. Thomson's second experiment was performed by placing a light paddle wheel between cathode and anode to study the particulate nature of the cathode rays.
- ☞ J. J. Thomson performed the third and fourth experiments to investigate the negative charge of the cathode ray by passing cathode rays through electric and magnetic fields. Thomson concluded that the particles had a net negative charge; these particles are now called **electrons**.

In 1920, in his discovery of the nucleus, Rutherford targeted a stream of positively charged  $\alpha$ -particles at a very thin gold foil target and inspected how the  $\alpha$ -particles were scattered by the foil. He inspected that a small fraction of the  $\alpha$ -particles were deflected at large angles, and some were reflected directly back at the source. Rutherford's results were not consistent with the Dalton's atomic model in which the mass and positive charges are distributed regularly throughout the volume of an atom. Instead, they strongly suggested that both the mass and positive charge are concentrated in a minute fraction of the volume of an atom, which Rutherford called the nucleus. Rutherford, however, was cornered by the other scientists by the question: "Why does the nucleus not disintegrate in spite of repulsion among the protons?" To explain the stability of the nucleus, Rutherford predicted the presence of neutral particles.

## Chemistry Grade 9

The English physicist, James Chadwick bombarded Beryllium nuclei with  $\alpha$ -particles and observed some radiations that possess material particles and did not deflect in an electric field. This confirmed the fact that these rays contained neutral particles. He called these neutral particles **neutrons**.

**Electrons** are one of three fundamental particles that make up the atoms. Electrons are extremely small ( $5.4858 \times 10^{-4}$  amu) and contribute almost nothing to the total mass of an atom. The electric charge of an electron is -1.

**The proton** is one of the three sub-atomic particles found in the nucleus of an atom. Protons have a positive electrical charge of one (+1) and a mass of 1.0073 atomic mass unit (amu).

**Neutrons** are subatomic particles found inside the nucleus of an atom. They have no charge. The mass of a neutron is a little greater (1.0087 amu) than the mass of a proton. Together with protons, they make up virtually all of the mass of an atom. Scientists are always interested in atomic number and how it differs between different elements since an atom of one element can be distinguished from an atom of another element by the number of protons in its nucleus. The number of protons in an atom is called its **atomic number (Z)**.

The mass number (A) of an atom is the total number of protons and neutrons in its nucleus. It is also known as the total number of nucleons in the atom's nucleus. It is calculated by using the formula:

$$\text{Mass number } A = (\text{number of protons}) + (\text{number of neutrons})$$

To write a **nuclear symbol**, the mass number is placed at the upper left (superscript) of the chemical symbol, and the atomic number is placed at the lower left (subscript) of the symbol.

All atoms of the same element have the same number of protons, but some may have different numbers of **neutrons**. Atoms of the same element that differ in their numbers of neutrons are called isotopes. Different isotopes of an element generally have the same physical and chemical properties because they have the same numbers of protons and electrons.

Mass of a single atom is very, very small. Using a modern device called a **mass spectrometer**; it is possible to measure such tiny masses. By definition, one atom of carbon-12 is assigned a mass of 12 atomic mass units (amu). An atomic mass unit is defined as a mass equal to one-twelfth the mass of an atom of carbon-12 or  $1.992646547 \times 10^{-23}$  g, which is assigned an atomic mass of 12 units. In this scale, 1 atomic mass unit (amu) corresponds to  $1.660539040 \times 10^{-24}$  g. The mass of any isotope of any element is expressed in relation to the carbon-12 standard.

Since many elements have some isotopes, chemists use average atomic mass. The average atomic mass is merely a weighted average of the masses of all the isotopes.

We can calculate this by the following equation:

$$\text{Average Atomic Mass} = (\% \text{isotope 1})(\text{mass of isotope 1}) + (\% \text{isotope 2})(\text{mass of isotope 2}) + \dots$$

Today, in chemistry, the principal energy level or the main energy level of an electron refers to the shell in which the electron is located relative to the atom's nucleus. This level is denoted by the principal quantum number  $n$  ( 1, 2, 3, etc or K, L, M, N, etc).

The electron configuration of an element describes how electrons are distributed in their energy levels or shells. Filling energy levels with electrons begins from the lower in energy or the shell closer to the nucleus i.e., K shell and goes on sequentially to L, M, N, etc. The maximum number of electrons that can be filled in the valence shell is 8, that in the penultimate shell is 18, and the anti-penultimate shell has a maximum capacity of 32 electrons.

The electrons that occupy the outermost shell of an atom are called valence electrons. Valence electrons are furthest from the nucleus of the atom. They are the most easily lost, and the ones that determine the element's chemical properties, and how an atom will react.

## Review Exercise

### Part I: Basic level questions

Provide short answer for the following questions.

1. Which postulate of Dalton's Atomic Theory is considered to be correct even today?
2. "Like atoms are identical in all respects". This statement of Dalton's Atomic Theory was contradicted. What discovery did contradict this?
3. What was the basis for the proposal of Dalton's Atomic Theory?
4. List the three statements that make up the Modern Atomic Theory.
5. Explain how atoms are composed.
6. Why was gas at low pressure taken by Thomson while experimenting?
7. Tell the mass and the charge of the fundamental particles of an atom.
8. Which is larger, a proton or an electron?
9. Which is larger, a neutron or an electron?
10. What is an atomic model?
11. Who discovered the protons? Based on what experiment was he able to discover these protons?
12. Where are most of the mass of an atom located?
13. With the increase in the radius of the orbit, the energy of an electron \_\_\_\_\_.
14. What is an  $\alpha$  particle?
15. Describe J. J. Thomson's Atomic Model.

## Chemistry Grade 9

16. What are the observations and conclusions drawn by J.J. Thomson while conducting experiments with discharge tube for studying the properties of cathode rays?
17. Sketch a diagram of a boron atom, which has five protons and six neutrons in its nucleus.
18. Sketch a diagram of a helium atom, which has two protons and two neutrons in its nucleus.
19. Define an atomic number. What is the atomic number for a boron atom?
20. What is the atomic number of helium?
21. Define an isotope and give example(s).
22. What is the difference between deuterium and tritium?
23. Which pair represents isotopes?
  - a.  ${}_2\text{He}^4$  and  ${}_2\text{He}^3$
  - b.  ${}_{26}\text{Fe}^{56}$  and  ${}_{25}\text{Mn}^{56}$
  - c.  ${}_{14}\text{Si}^{28}$  and  ${}_{15}\text{P}^{31}$
  - d.  ${}_{20}\text{Ca}^{40}$  and  ${}_{19}\text{K}^{40}$
  - e.  ${}_{26}\text{Fe}^{56}$  and  ${}_{26}\text{Fe}^{58}$
  - f.  ${}_{92}\text{U}^{238}$  and  ${}_{92}\text{U}^{235}$
24. Write complete symbols of each atom, including their atomic number and the mass number.
  - a. An oxygen atom with 8 protons and 8 neutrons
  - b. A potassium atom with 19 protons and 20 neutrons
  - c. A lithium atom with 3 protons and 4 neutrons
  - d. A magnesium atom with 12 protons and 12 neutrons
  - e. A magnesium atom with 12 protons and 13 neutrons
  - f. A xenon atom with 54 protons and 77 neutrons
25. Americium-241 (Am-241) is an isotope used in smoke detectors. What is the complete symbol for this isotope?
26. Carbon-14 is an isotope used to perform radioactive dating tests on previously living material. What is the complete symbol for this isotope?

### Part II: Intermediary level questions

Tell whether the following statements are True or False.

27. According to Thomson's Atomic Model, electrons revolve around the nucleus.
28. In a discharge tube, anode rays originate when electrons collide with gas molecules.
29.  ${}_8\text{O}^{16}$  and  ${}_8\text{O}^{18}$  are isotopes while  ${}_{20}\text{Ca}^{40}$  and  ${}_{18}\text{Ar}^{40}$  are isobars.
30.  $\alpha$ -ray scattering experiment proved that the positive particles are present in the extra nuclear part of an atom.



**Fill in the Blanks.**

31. Anode rays are deflected towards the negative plate in the presence of an electric field because they consist of \_\_\_\_\_ particles.
32. Some of the  $\alpha$ -rays' deflection in acute and obtuse angles are due to the presence of the \_\_\_\_\_ in the center of the atom.
33. The energy of an electron present in the first orbit of an atom is \_\_\_\_\_ than the energy of an electron in the other orbits.

**Choose the correct answer from the given alternatives**

34. Which of the following concepts was not considered in Rutherford's Atomic Model?
  - a. The electrical neutrality of an atom.
  - b. The quantization of energy.
  - c. The electrons revolve around the nucleus at very high speeds.
  - d. The existence of nuclear forces of attraction on the electrons.
35. When alpha particles are sent through a thin metal foil, only one out of ten thousand of them are rebounded. This observation led to the conclusion that
  - a. Positively charged particles are concentrated at the centre of the atom.
  - b. More number of electrons are revolving around the nucleus of the atom.
  - c. Unit positive charge is only present in an atom.
  - d. The massive sphere with a more negative charge and unit positive charge is present at the center of the atom.
36. Canal ray experiment lead to the discovery of \_\_\_\_\_.
 

a. protons	c. electrons
b. neutrons	d. nucleus
37. In which of the following pairs of shells that energy difference between two adjacent orbits is minimum?
 

a. K, L	c. M, N
b. L, M	d. N, O
38. Assertion A: An electron in the inner orbit is more tightly bound to the nucleus.  
Reason B: The greater the absolute value of the energy of an electron, the more tightly the electron is bound to the nucleus.
  - a. Both A and B are true but B is not the appropriate reason for A.
  - b. Both A and B are individually correct and B is the correct reason for A.
  - c. A is correct but B is not correct.
  - d. Both A and B are not correct.
39. If two naturally occurring isotopes of an element are  ${}_7\text{X}^{15}$  and  ${}_7\text{X}^{11}$ , what is the percentage composition of each isotope of X occurring respectively if the average atomic weight accounts for 14?
 

a. 95, 5	c. 75, 25
b. 80, 20	d. 65, 35



# UNIT 4

The periodic table displays elements from Hydrogen (H) to Oganesson (Og). It is organized into periods (rows) and groups (columns). Key features include:
 

- Main-Group Elements:** Groups 1, 2, 13, 14, 15, 16, and 17.
- Transition Metals:** Groups 3 through 10.
- Inner Transition Metals:** Lanthanides (groups 3-10, periods 6-7) and Actinides (groups 3-10, period 7).
- Periods:** Labeled 1 through 7 on the left side.
- Groups:** Labeled I through VIII at the top.
- Atomic Number, Symbol, and Atomic Mass:** Provided for each element.

## PERIODIC CLASSIFICATION OF ELEMENTS

### Unit Outcomes

After completing the unit, you will be able to

- ☞ explain the historical development of the periodic classification of the elements;
- ☞ describe the periodic classification of the elements;
- ☞ develop the skills of correlating the electron configuration of elements with the periodicity of the elements, predicting the trends of periodic properties of elements in the periodic table;
- ☞ acquire skills of classifications based on patterns in chemistry;
- ☞ demonstrate scientific inquiry skills: observing, inferring, predicting, classifying, comparing and contrasting, making models, communicating, measuring, asking questions, interpreting illustrations, drawing conclusion, applying concepts and problem solving.





### Start-up Activity

By forming groups discuss the following issues and present your conclusion to the class.

How can you use a table of repeating events to predict the next events? Table 2.1 shows a familiar table of repeating properties. What is it?

Of course, it is a calendar of month of Nehassie, 2013 E.C and it is missing some information. You can determine what is missing and fill in the blanks. Look at the calendar again. The calendar has columns of days, Monday through Sunday. The calendar also has horizontal rows. They are its weeks.

1. Examine the information surrounding each empty spot. Can you tell what information is needed in each empty spot?
2. Fill in the missing information.

For example: Conclude and Apply

- a. One day in column 4 is marked X, and a day in column 5 is marked Y. What dates belong to these positions? Discuss your answers in your group.
- b. Column 3 does not have a name. What is the correct name of this column?
- c. What dates are included in the third row of the table?
- d. What day would the 25<sup>th</sup> of the previous month (month of Hamle, 2013 E.C) have been? What row of this table would it appear in?
- e. How do you relate this periodicity with the periodic classification of elements?

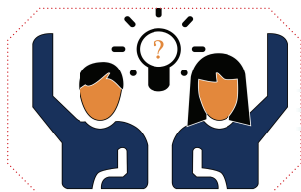
**Table 4.1** Periodicity in month.

Mon	Tue		Thu	Fri	Sat	Su
					1	2
3	4	5	6	7	8	9
10	11	12	X	y	15	16
17	18	29	20	21	22	23
24	25	26	27	28	29	30

## 4.1 Historical Development of Periodic Classification of the Elements

Learning competencies

At the end of this section, you should be able to describe periodicity.



### Activity 4.1

By forming groups discuss the following issues and present your conclusion to the class.

- The relationship to the first octave in music with eight notes is observed in musical instrument. That means the first sound repeats itself on the eighth (Do Ri Mi Fa So La Si Do). In group discuss how the Ethiopian cultural music does the same.
- What can you say about the attempts by scientists and what was the basis of their classification?
- Can you explain the basis of early classification of elements by scientists?

In the nineteenth century, when chemists had only a vague idea of atoms and molecules and did not know of the existence of electrons and protons, they devised the periodic table using their knowledge of atomic masses. Accurate measurements of the atomic masses of many elements had already been made. Arranging elements according to their atomic masses in a periodic table seemed logical to chemists, who felt that chemical behaviour should somehow be related to atomic mass.

### 4.1.1 Dobereiner's Triads

In 1829, German chemist Dobereiner was able to identify several groups of three elements that showed similarity in physical and chemical properties. He observed that in the set of three elements having similar properties (called triads), the atomic weight of the middle element is the arithmetic mean of the atomic weights of other two elements. Some examples of Dobereiner's triads are as follows (**Table 4.2**):

**Table 4.2** Examples of Dobereiner's triads.

	Element	At. Weight	Mean weight of first and last element
(i)	Li	7	$\frac{7+39}{2} = 23$
	Na	23	
	K	39	
(ii)	Ca	40	$\frac{40+137}{2} = 88.5$
	Sr	88	
	Ba	137	

(iii)	Cl	35.5	$\frac{35.5+127}{2} = 81.25$
	Br	80	
	I	127	
(iv)	S	32	$\frac{32+127.6}{2} = 79.8$
	Se	79	
	Te	127.6	

Only few such triads were available at that time and day by day as many more elements were discovered, the rule could no longer be generalized.

### 4.1.2 Newland's Law of Octaves

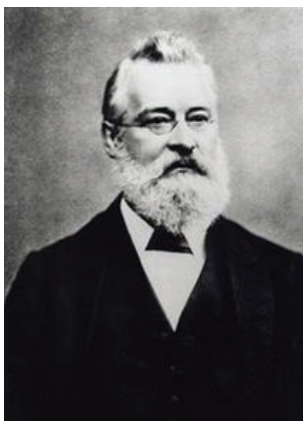
An English chemist Alexander Newlands (**Figure 4.1**) made the next attempt at classification of elements. He arranged the 56 elements known then in increasing order of their atomic weight and observed that, “the properties of every eighth element are similar to that of the first one”. He compared this relationship to the first octave in music with eight notes and called it Newlands’ law of octaves. How do you relate **Activity 4.1** with the Newland’s Law of Octaves? The elements were arranged as follows (**Table 4.3**):

**Table 4.3** Newlands’ law of octaves.

Sa	Re	Ga	Ma	Pa	Dha	Ni	Sa
Li	Be	B	C	N	O	F	Na
Na	Mg	Al	Si	P	S	Cl	K
K	Ca						

The limitations of this classification of elements were that:

- The inert gases were not discovered till then.
- Beyond Ca, this repetition was not observed.



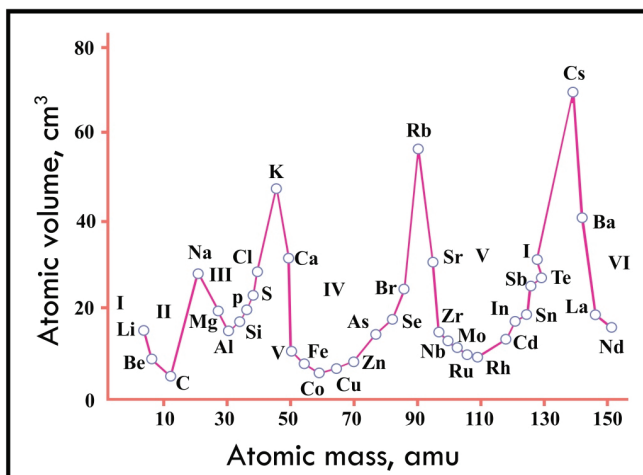
**Figure 4.1** John Alexander Reina Newlands was an English chemist who worked on the development of the periodic table. He noticed that elemental properties repeated every seventh (or multiple of seven) elements, as musical notes repeat every eighth note.

### Lothar Meyer's curve

Lothar Meyer plotted the atomic volume versus atomic mass, where the atomic volume is defined as follows:

$$\text{Atomic volume} = \frac{\text{Gram atomic mass of an element}}{\text{Density (in g/ml)}}$$

The curve obtained is referred to as Lothar Meyer's curve and is shown in **Figure 4.2**.



**Figure 4.2** Lothar Meyer's curve.

From this plot, Lothar Meyer observed that:

- The elements having similar properties are in the same position of the curve. For example,
  - Alkali metals (Li, Na, K, Rb, Cs) are at the peaks of the curve.
  - Alkaline earth metals (Be, Mg, Ca, Sr, Ba) are at the descending part of the curve.
  - Halogens (F, Cl, Br, I) are at the ascending part of the curve.
  - Most of the transition elements are lying in the broad minimas of the curve.
- The atomic volume of the elements changes periodically in a period, it initially decreases and then increases with broad minimas.
- The atomic volume increases in a group, that is, in elements that exhibit similar properties.
- Many other physical properties of the elements also change in a periodic manner like melting point, boiling point, density, thermal expansion coefficient, etc.

Based on these observations, he proposed that the physical properties of elements are periodic functions of their atomic weights and this formed the basis of Mendeleev's periodic table, which was also presented around the same time.

## 4.2 Mendeleev's Classification of the Elements

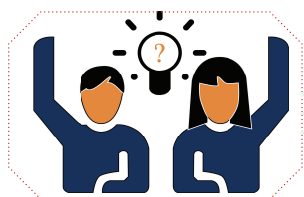
### Learning competencies

At the end of this section, you should be able to state Mendeleev's Periodic law.

Form group and by referring the Mendeleev's periodic table do the following tasks and present your findings in the class. Here are the first 18 elements with their respective atomic masses. Arrange them in increasing order of atomic mass as Mendeleev did.

Element	Atomic mass	Element	Atomic mass
A	1.008	J	20.180
B	4.003	K	22.990
C	6.941	L	24.305
D	9.012	M	26.982
E	10.811	N	28.086
F	12.011	O	30.974
G	14.007	P	32.065
H	15.999	Q	35.453
I	18.998	R	39.948

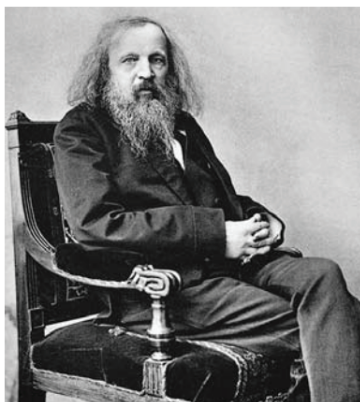
1. Draw sets of horizontal and vertical boxes similar to Mendeleev's periodic table and label the group and period (see **Table 4.4**). In order of increasing atomic weight, fill into each set the letters (A-R). How many groups and periods did you get from your arrangement?
2. Label the letters (A-R) by their respective chemical symbols of similar atomic weight.
3. Do you see any regular patterns on the arrangement of elements?



### Activity 4.2

The earliest version of the current form of periodic table was presented simultaneously by Dmitri Mendeleev of Russia (**Figure 4.3**) and Lothar Meyer of Germany. Both the scientists arranged the elements in order of increasing atomic weights and observed that elements with similar properties (in families) appeared at regular intervals.





**Figure 4.3** Dmitri Ivanovich Mendeleev (1834–1907) Mendeleev constructed a periodic table as part of his effort to systematize chemistry. He received many international honors for his work, but his reception in czarist Russia was mixed. He had pushed for political reforms and made many enemies as a result.

### 4.2.1 Mendeleev's Periodic Law

Mendeleev's periodic law stated *that the physical and chemical properties of elements are the periodic function of their atomic weights.*

In 1871, Mendeleev published a short periodic table which

1. consisted of only 63 elements. Inert gases were not included as they were not discovered at that time.
2. these elements were arranged in seven horizontal rows called as periods and eight vertical columns called as groups.
3. some vacant sites were specified for undiscovered elements and their properties predicted. These were found true and verified when these elements were discovered later.

In the periodic table, so constructed, the elements in the same families (e.g., lithium, sodium, potassium) were arranged in vertical columns designated as Groups I, II, III, IV, V, VI, VII, VIII. The horizontal rows were referred to as series (**Table 4.4**).

Mendeleev's periodic table was later modified after the discovery of inert gases and several other elements. The inert gases were placed in new Group 0. Each long period was divided into two series, named as odd and even depending on the serial number. The first seven elements formed the even series and the last seven elements formed the odd series (not including the inert gases). The vertical Groups I to VII were further divided into two subgroups A and B to accommodate elements with difference in properties. The elements of even series in the long periods were placed in subgroup A while the elements of odd series were placed in the B subgroup. The Group 0 was not split further and in Group VIII three sets containing three elements each were placed.

**Table 4.4** Modern version of Mendeleev's short periodic table

Group \ Period	0	I		II		III		IV		V		VI		VII		VIII		
		A	B	A	B	A	B	A	B	A	B	A	B	A	B			
1	He 2	H 1																
2	Ne 10	Li 3	Be 4			B 5		C 6		N 7		O 8		F 9				
3	Ar 18	Na 11	Mg 12			Al 13		Si 14		P 15		S 16		Cl 17				
4		K 19	Ca 20		Sc 21		Ti 22		V 23		Cr 24		Mn 25		Fe 26	Co 27	Ni 28	
	Kr 18		Cu 29		Zn 30		Ga 31		Ge 32		As 33		Se 34		Br 35			
5		Rb 37	Sr 38		Y 39		Zr 40		Nb 41		Mo 42		Tc 43		Ru 44	Rh 45	Pd 46	
	Xe 54		Ag 47		Cd 48		In 49		Sn 50		Sb 51		Te 52		I 53			
6		Cs 55	Ba 20		La* 57-71		Hf 72		Ta 73		W 74		Re 75		Os 76	Ir 77	Pt 78	
	Rn 86		Au 79		Hg 80		Tl 81		Pb 82		Bi 83		Po 84		At 85			
7		Fr 87	Ra 88		Ac** 85-103													
The Rare Earths																		
*Lanthanide series (6 <sup>th</sup> period)		Ce 58	Pr 59	Nd 60	Pm 61	Sm 62	Eu 63	Gd 64	Tb 65	Dy 66	Ho 67	Er 68	Tm 69	Yb 70	Lu 71			
**Actinide series (7 <sup>th</sup> period)		Th 90	Pa 91	U 92	Np 93	Pu 94	Am 95	Cm 96	Bk 97	Cf 98	Es 99	Fm 100	Md 101	No 102	Lr 103			



### Exercise 4.1

Analyzing the modern version of the Mendeleev's Periodic table (**Table 4.4**) give appropriate answers for the following questions.

- Why does the first period contain only two elements?
- To which group and period do the following elements belong?
  - carbon
  - neon
  - aluminum
  - potassium
  - calcium
  - sulphur

### 4.2.2 Periodicity

Important characteristics of modern version of Mendeleev's short periodic table are listed as follows:

### I. Horizontal Rows or Periods

1. First period consists of 2 elements and is known as very short period.
2. Second period consists of 8 elements and is known as first short period.
3. Third period consists of 8 elements and is known as second short period.
4. Fourth period consists of 18 elements and is known as first long period.
5. Fifth period consists of 18 elements and is known as second long period.
6. Sixth period consists of 32 elements.
7. Seventh period also consists of 32 elements and both period six and period seven are known as very loang periods.

### II. Vertical Columns or Groups

1. Group IA elements are called as alkali metals (except H).
2. Group IIA elements are called as alkaline earth metals.
3. Group VB elements are called as pnico gens.
4. Group VIB elements are called as chalcogens.
5. Group VIIB elements are called as halogens.
6. Group 0 elements are called as noble (inert) gases.

The merits of Mendeleev's periodic table are listed as follows:

1. The study of properties of elements became more systematic and easier.
2. There are several vacant positions from which the guidance of discovery of new elements was found.

The demerits of Mendeleev's periodic table are given as follows:

Some of the elements are wrongly placed though their atomic weights are larger compared to the next one. For example,

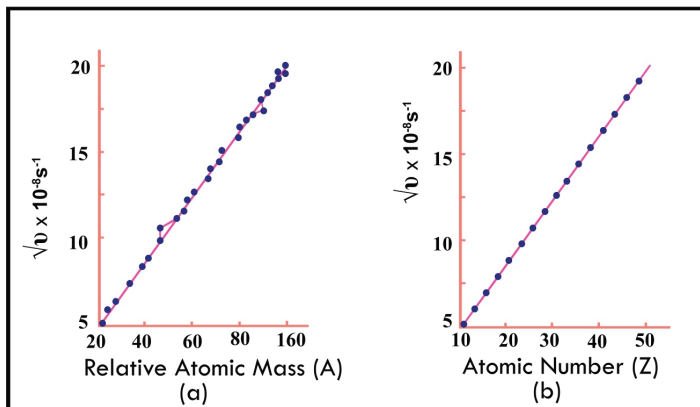
(i)	Ar:40	(ii)	Te: 127.6	(iii)	Co: 58.9
	K:39		I: 126.9		Ni: 58.6

### Moseley's work

In 1913, Moseley performed an experiment in which he bombarded high speed electrons on different metal surfaces and obtained X-rays. He observed that there existed a systematic mathematical relationship between the wavelengths of the X-rays produced and the atomic numbers of the elements. This came to be known as Moseley's law and is expressed as:

$$\sqrt{\nu} \propto Z$$

where  $\nu$  is the frequency of X-rays and  $Z$  is the atomic number of elements. The plot of  $\sqrt{\nu}$  vs.  $Z$  is a straight line (**Figure 4.4**)



**Figure 4.4** Plots obtained in Moseley's experiments.

Moseley's experiment showed that the proper sequence criterion for the periodic arrangement of atoms was not atomic weight but atomic number. The cause of similarity of properties was the repetition of the outer shell electronic configuration at regular intervals. This observation formed the basis of the modern periodic table.

### 4.3 The Modern Periodic Table

#### Learning competencies

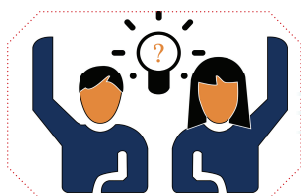
At the end of this section, you should be able to

- ☞ state modern periodic law
- ☞ describe period
- ☞ describe group
- ☞ tell the number of groups and periods in the modern Periodic table
- ☞ tell the number of elements in each period
- ☞ predict the period and group of an element from its atomic number

Form group and by referring the modern periodic table do the following tasks and present your findings in the class.

Element	Atomic Number	Element	Atomic Number
A	1	J	10
B	2	K	11
C	3	L	12
D	4	M	13
E	5	N	14
F	6	O	15
G	7	P	16
H	8	Q	17
I	9	R	18

- List down the elements from atomic number A up to R. Write the respective electronic configurations.
- Draw sets of vertical boxes. In order of increasing atomic number, fill into each set the symbol of all elements having the same outer electron configurations. How many sets are there? Record your answer.
- Draw sets of horizontal boxes. In order of increasing atomic number, fill into each set the symbols of all elements having the same number of shells. How many sets are there? How many elements are there in each set? Record your answers.
- Do you see any regular patterns that you created in Steps 2 and 3?
- Draw one complete table which shows all elements; with the same number of outermost electrons in a vertical column filling the same outer electron shell in a horizontal row.



### Activity 4.3

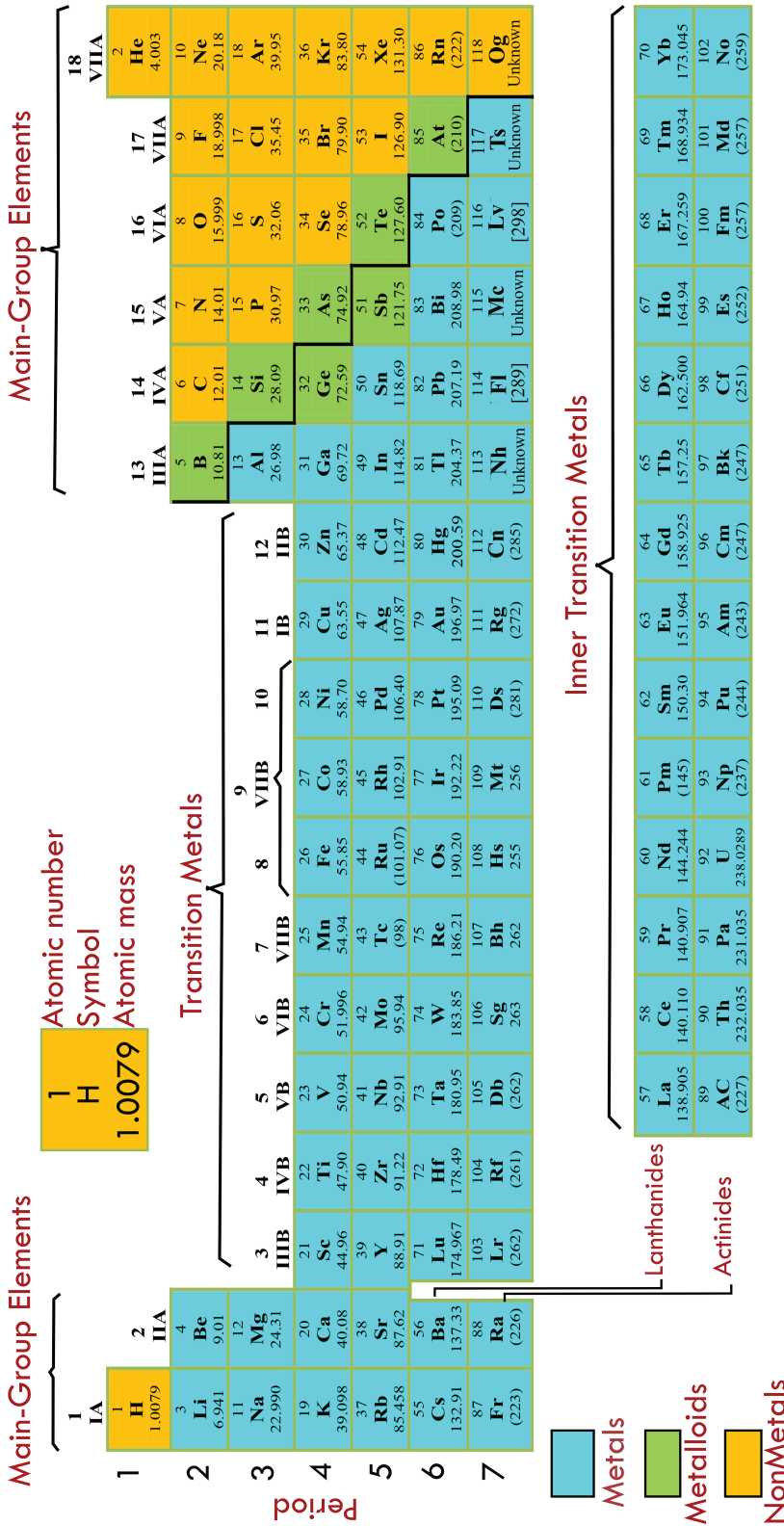


Figure 4.5 The long form of modern periodic table and its segments.

### 4.3.1 The Periodic Law

According to the modern periodic law, the physical and chemical properties of the elements are the periodic functions of their atomic number. The long form of periodic table based upon the modern periodic law is depicted in **Figure 4.5**. Note that the arrangement of A and B subgroups is different from that in the modified form of Mendeleev's periodic table. The left and right corners of the table are assigned as sub-groups A and the middle of the periodic table is assigned as subgroups B.

### 4.3.2 Groups and Periods

Many different forms of the periodic table have been published since Mendeleev's time. Today, the long form of the periodic table, which is called the modern periodic table, is commonly in use. It is based on the modern periodic law. In the modern periodic table, elements are arranged in periods and groups.

What are the basis for classifying the elements into groups and periods? What are the similarities and differences in the electron configuration of S and Cl?

**Periods:** The horizontal rows of elements in the periodic table are called periods or series. Elements in a period are arranged in increasing order of their atomic numbers from left to right. There are 7 periods in the modern periodic table, and each period is represented by an Arabic numeral: 1, 2 . . . and 7.

- ☞ Elements in the same period have the same number of shells.
- ☞ Periods 1, 2, and 3 are called short periods while periods 4, 5, and 6 are known as long periods.
- ☞ Period 1 contains only 2 elements, hydrogen and helium. Period 2 and period 3 contain 8 elements each.
- ☞ Period 4 and period 5 contain 18 elements each. Period 6, the longest period, has 32 elements. Period 7, 31 elements. Period 7 element is radioactive and/or an artificial element.
- ☞ Except for the first period, all periods start with an alkali metal and ends with a noble gas.

**Table 4.5** The number of elements in a given period and the orbitals being filled.

Period number	Orbitals occupied	Number of elements
1	1s	2
2	2s, 2p	8
3	3s, 3p	8
4	4s, 3d, 4p	18
		and so on

The position of an element in a given period can be determined by the number of shells occupied with its electrons. Accordingly, the number of shell is equal to the number of period to which the element belongs.

## Chemistry Grade 9

### Example 4.1

Electronic configuration of  ${}^{23}_{11}\text{Na} = 1s^2 2s^2 2p^6 3s^1$  (2, 8, 1). Sodium has 3 main shells. Hence, sodium is found in period 3.

### Example 4.2

By looking example above write the electron configuration of  ${}_{9}\text{F}$  and  ${}_{17}\text{Cl}$ . What are the similarities and differences in the electron configuration of F and Cl?

Electronic configuration of  ${}_{9}\text{F} = 1s^2 2s^2 2p^5$  (2, 7) and the electronic configuration of  ${}_{17}\text{Cl} = 1s^2 2s^2 2p^6 3s^2 3p^5$  (2, 8, 7). Both have the same number of electrons in their valence shell. Fluorine has two shells whereas chlorine has three shells.

**Groups:** are the vertical columns of elements in the periodic table. There are 18 columns or groups in the modern periodic table. Group numbers are usually designated with the numbers 1 to 8 each followed by the letter A or B.

These are:

IA . . . . .	VIIIA	Main groups (A groups)
IB . . . . .	VIIIB	Sub groups (B groups)

Elements in a given group have the same number of outermost shell electrons. Elements in the same group have similar chemical properties. For the main group elements the group number equals the number of valence electrons.

### Example 4.3

Electronic configuration of  ${}^{35}_{17}\text{Cl} = 1s^2 2s^2 2p^6 3s^2 3p^5$  (2, 8, 7). The number of valence electrons of chlorine is 7. Hence chlorine is found in Group VIIA.

## 4.3.3 Classification of the Elements

### Learning competencies

At the end of this section, you should be able to

- ☞ explain the relationship between the electronic configuration and the structure of the modern Periodic table
- ☞ describe the three classes of the elements in the modern Periodic table
- ☞ give group names for the main group elements
- ☞ classify the periods into short, long and incomplete periods
- ☞ tell the number of groups and periods in the modern Periodic table
- ☞ tell the number of elements in each period
- ☞ predict the period and group of an element from its atomic number
- ☞ tell the block and group of an element from its electronic configuration



The assignment of all the electrons in an atom into specific shells or orbitals (s, p, d, f) is known as the element's electronic configuration. The elements can be arranged in the long form of the periodic table based on the electronic configuration and classified as s, p, d and f-block elements.

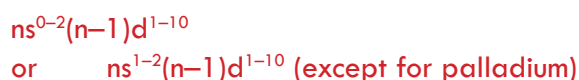
1. **s-block elements:** If the last electron enters into s-orbital, the elements are called as s-block elements.

The general valence (outermost) shell electronic configuration is given by  $ns^{1-2}$ . That means [IG]  $ns^1$  for Alkali metals and [IG]  $ns^2$  for Alkaline earth metals, where IG represents the inert gas core.

2. **p-block elements:** If the last electron enters into the p-orbital, the elements are called as p-block elements. The general valence shell electronic configuration is  $ns^2np^{1-6}$ . The p-block elements are placed in Group number IIIA to VIIIA.

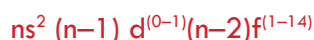
- a. Valence shell electrons for s-block elements is equal to the number of electrons in the s orbital having the highest principal quantum number.
- b. Valence shell electrons for p-block elements are equal to the number of electrons in the s and p orbitals having highest principal quantum number.
- c. The total number of valence shell electrons is equal to its group number according to A and B convention.
- d. He ( $ns^2$ ) is excluded from p-block in terms of electronic configuration and it is better to consider it as s-block element. But according to its chemical behavior it is justified to place it in Group VIII.

3. **d-block elements:** If the last electron enters into d orbital, the elements are called d-block elements (except Thorium). The general valence shell electronic configuration is:



Total valence shell electrons of d-block elements = Total number of electrons in the outermost shell ( $ns$  orbital) and penultimate shell [( $n - 1$ ) d orbitals].

4. **f-block elements:** If the last electron of the elements enters into f-orbital, they are considered as f-block elements. The general valence shell electronic configuration is:



Total valence shell electrons = Electrons present in  $ns$ , ( $n - 1$ )d and ( $n - 2$ )f orbitals or subshells.



## Exercise 4.2

Perform the following tasks in groups and present your conclusion to the class. For the following elements, determine the valence electrons, and identify the sub-shell (s, p, d or f) in which the last electron of each element enters.

- |                                 |                                 |
|---------------------------------|---------------------------------|
| a. Nitrogen (atomic number = 7) | f. Krypton (atomic number = 36) |
| b. Sodium (atomic number = 11)  | g. Cerium (atomic number = 58)  |
| c. Silicon (atomic number = 14) |                                 |
| d. Iron (atomic number = 26)    |                                 |
| e. Zinc (atomic number = 30)    |                                 |

### 4.3.4 The Representative Elements

Referring to **Figure 4.6**, the **representative elements** (also called **main group elements**) are the elements in Groups IA through VIIA, all of which have incompletely filled s or p subshells of the highest principal quantum number. With the exception of helium, the noble gases (the Group VIIIA elements) all have a completely filled p subshell. (The electron configurations are  $1s^2$  for helium and  $ns^2np^6$  for the other noble gases, in which n is the principal quantum number for the outermost shell). Some main groups have traditional names and others as family of the first member in the group which are often used in textbooks. Group I – alkali metals, Group II – alkaline earth metals, Group III – boron family, Group IV – carbon family, Group V – nitrogen family, Group VI – oxygen family, Group VII – halogens, Group VIII – noble gases.

A clear pattern emerges when we examine the electron configurations of the elements in a particular group. The electron configurations for Groups IA and IIA elements are shown in **Figure 4.6**. We see that all members of the Group IA alkali metals have similar outer electron configurations; each has a noble gas core and an  $ns^1$  configuration of the outer electron. Similarly, the Group IIA alkaline earth metals have a noble gas core and an  $ns^2$  configuration of the outer electrons. **The outer electrons of an atom, which are those involved in chemical bonding, are often called the valence electrons.** Having the same number of valence electrons accounts for similarities in chemical behavior among the elements within each of these groups. This observation holds true also for the halogens (the Group VIIA elements), which have outer electron configurations of  $ns^2np^5$  and exhibit very similar properties. We must be careful, however, in predicting properties for Groups IIIA through VIA. For example, the elements in Group IVA all have the same outer electron configuration,  $ns^2np^4$ , but there is much variation in chemical properties among these elements: Carbon is a nonmetal, silicon and germanium are metalloids, and tin and lead are metals.

1	1A	1	2	3	4	5	6	7	8	9	10	11	12	13	14	15	16	17	18
1	H 1s <sup>1</sup>	2	3	4	5	6	7	8	9	10	11	12	13	14	15	16	17	18	8A
2	Li 2s <sup>1</sup>	2A	3	4	5	6	7	8	9	10	11	12	13	14	15	16	17	18	
3	Na 3s <sup>1</sup>		3	4	5	6	7	8	9	10	11	12	13	14	15	16	17	18	
4	K 4s <sup>1</sup>		3	4	5	6	7	8	9	10	11	12	13	14	15	16	17	18	
5	Rb 5s <sup>1</sup>		3	4	5	6	7	8	9	10	11	12	13	14	15	16	17	18	
6	Cs 6s <sup>1</sup>		3	4	5	6	7	8	9	10	11	12	13	14	15	16	17	18	
7	Fr 7s <sup>1</sup>		3	4	5	6	7	8	9	10	11	12	13	14	15	16	17	18	
			3B	4B	5B	6B	7B	8B	9	10	11B	12B	13A	14A	15A	16A	17A		
			21	22	23	24	25	26	27	28	29	30	31	32	33	34	35	36	
			Sc 4s <sup>2</sup> 3d <sup>1</sup>	Ti 4s <sup>2</sup> 3d <sup>2</sup>	V 4s <sup>2</sup> 3d <sup>3</sup>	Cr 4s <sup>1</sup> 3d <sup>5</sup>	Mn 4s <sup>2</sup> 3d <sup>5</sup>	Fe 4s <sup>2</sup> 3d <sup>6</sup>	Co 4s <sup>2</sup> 3d <sup>7</sup>	Ni 4s <sup>2</sup> 3d <sup>8</sup>	Cu 4s <sup>1</sup> 3d <sup>10</sup>	Zn 4s <sup>2</sup> 3d <sup>10</sup>	Ga 4s <sup>2</sup> 4p <sup>1</sup>	Ge 4s <sup>2</sup> 4p <sup>2</sup>	As 4s <sup>2</sup> 4p <sup>3</sup>	Se 4s <sup>2</sup> 4p <sup>4</sup>	Br 4s <sup>2</sup> 4p <sup>5</sup>	Kr 4s <sup>2</sup> 4p <sup>6</sup>	
			39	40	41	42	43	44	45	46	47	48	49	50	51	52	53	54	
			Y 5s <sup>2</sup> 4d <sup>1</sup>	Zr 5s <sup>2</sup> 4d <sup>2</sup>	Nb 5s <sup>1</sup> 4d <sup>5</sup>	Mo 5s <sup>1</sup> 4d <sup>5</sup>	Tc 5s <sup>2</sup> 4d <sup>5</sup>	Ru 5s <sup>1</sup> 4d <sup>7</sup>	Rh 5s <sup>1</sup> 4d <sup>8</sup>	Pd 4d <sup>10</sup>	Ag 5s <sup>1</sup> 4d <sup>10</sup>	Cd 5s <sup>2</sup> 4d <sup>10</sup>	In 5s <sup>2</sup> 5p <sup>1</sup>	Sn 5s <sup>2</sup> 5p <sup>2</sup>	Sb 5s <sup>2</sup> 5p <sup>3</sup>	Te 5s <sup>2</sup> 5p <sup>4</sup>	I 5s <sup>2</sup> 5p <sup>5</sup>	Xe 5s <sup>2</sup> 5p <sup>6</sup>	
			57	72	73	74	75	76	77	78	79	80	81	82	83	84	85	86	
			La 6s <sup>2</sup> 5d <sup>1</sup>	Hf 6s <sup>2</sup> 5d <sup>2</sup>	Ta 6s <sup>2</sup> 5d <sup>3</sup>	W 6s <sup>2</sup> 5d <sup>4</sup>	Re 6s <sup>2</sup> 5d <sup>5</sup>	Os 6s <sup>2</sup> 5d <sup>6</sup>	Ir 6s <sup>2</sup> 5d <sup>7</sup>	Pt 6s <sup>1</sup> 5d <sup>9</sup>	Au 6s <sup>1</sup> 5d <sup>10</sup>	Hg 6s <sup>2</sup> 5d <sup>10</sup>	Tl 6s <sup>2</sup> 6p <sup>1</sup>	Pb 6s <sup>2</sup> 6p <sup>2</sup>	Bi 6s <sup>2</sup> 6p <sup>3</sup>	Po 6s <sup>2</sup> 6p <sup>4</sup>	At 6s <sup>2</sup> 6p <sup>5</sup>	Rn 6s <sup>2</sup> 6p <sup>6</sup>	
			89	104	105	106	107	108	109	110	111	112	(113)	(114)	(115)	(116)	(117)	(118)	
			Ac 7s <sup>2</sup> 6d <sup>1</sup>	Rf 7s <sup>2</sup> 6d <sup>2</sup>	Db 7s <sup>2</sup> 6d <sup>3</sup>	Sg 7s <sup>2</sup> 6d <sup>4</sup>	Bh 7s <sup>2</sup> 6d <sup>5</sup>	Hs 7s <sup>2</sup> 6d <sup>6</sup>	Mt 7s <sup>2</sup> 6d <sup>7</sup>	Ds 7s <sup>2</sup> 6d <sup>8</sup>	Rg 7s <sup>2</sup> 6d <sup>9</sup>	Cn 7s <sup>2</sup> 6d <sup>10</sup>	Nh 7s <sup>2</sup> 7p <sup>1</sup>	Fl 7s <sup>2</sup> 7p <sup>2</sup>	Mc 7s <sup>2</sup> 7p <sup>3</sup>	Lv 7s <sup>2</sup> 7p <sup>4</sup>	Ts 7s <sup>2</sup> 7p <sup>5</sup>	Og 7s <sup>2</sup> 7p <sup>6</sup>	
			58	59	60	61	62	63	64	65	66	67	68	69	70	71			
			Ce 6s <sup>2</sup> 4f <sup>1</sup> 5d <sup>1</sup>	Pr 6s <sup>2</sup> 4f <sup>3</sup>	Nd 6s <sup>2</sup> 4f <sup>4</sup>	Pm 6s <sup>2</sup> 4f <sup>6</sup>	Sm 6s <sup>2</sup> 4f <sup>6</sup>	Eu 6s <sup>2</sup> 4f <sup>7</sup>	Gd 6s <sup>2</sup> 4f <sup>7</sup> 5d <sup>1</sup>	Tb 6s <sup>2</sup> 4f <sup>9</sup>	Dy 6s <sup>2</sup> 4f <sup>10</sup>	Ho 6s <sup>2</sup> 4f <sup>11</sup>	Er 6s <sup>2</sup> 4f <sup>12</sup>	Tm 6s <sup>2</sup> 4f <sup>13</sup>	Yb 6s <sup>2</sup> 4f <sup>14</sup>	Lu 6s <sup>2</sup> 4f <sup>14</sup> 5d <sup>1</sup>			
			90	91	92	93	94	95	96	97	98	99	100	101	102	103			
			Th 7s <sup>2</sup> 6d <sup>2</sup>	Pa 7s <sup>2</sup> 5f <sup>6</sup> 6d <sup>1</sup>	U 7s <sup>2</sup> 5f <sup>6</sup> 6d <sup>1</sup>	Np 7s <sup>2</sup> 5f <sup>7</sup> 6d <sup>1</sup>	Pu 7s <sup>2</sup> 5f <sup>6</sup>	Am 7s <sup>2</sup> 5f <sup>7</sup>	Cm 7s <sup>2</sup> 5f <sup>7</sup> 6d <sup>1</sup>	Bk 7s <sup>2</sup> 5f <sup>9</sup>	Cf 7s <sup>2</sup> 5f <sup>10</sup>	Es 7s <sup>2</sup> 5f <sup>11</sup>	Fm 7s <sup>2</sup> 5f <sup>12</sup>	Md 7s <sup>2</sup> 5f <sup>13</sup>	No 7s <sup>2</sup> 5f <sup>14</sup>	Lr 7s <sup>2</sup> 5f <sup>14</sup> 6d <sup>1</sup>			

**Figure 4.6** The ground-state electron configurations of the elements. For simplicity, only the configurations of the outer electrons are shown.

## 4.4 The Major Trends in the Periodic Table

(Atomic size, ionization energy, electron affinity and electro negativity)

### Learning competencies

At the end of this section, you should be able to describe the four major trends (atomic size, ionization energy, electron affinity and electro negativity) in the periodic table.



In group discuss why:

- All the elements of a group have similar chemical properties.
- All the elements of a period have different chemical properties.
- The atomic radii of three elements A, B and C of a period of the periodic table are 186 pm, 104 pm and 143 pm respectively. Giving a reason, arrange these elements in the increasing order of atomic numbers in the period.

Periodic trends are patterns in elements on the periodic table. Major trends are electronegativity, ionization energy, electron affinity, atomic radius, and metallic character. The existence of these trends is due to the similarity in atomic structure of the elements in their groups or periods and because of the periodic nature of elements.

As we have seen, the electron configurations of the elements show a periodic variation with increasing atomic number. Consequently, there are also periodic variations in physical and chemical behaviour. In this section and sections 4.5 and 4.6, we will examine some physical properties of elements that are in the same group or period and additional properties that influence the chemical behavior of the elements. First, let's look at the concept of effective nuclear charge, which has a direct bearing on atomic size and on the tendency for ionization.

### 4.4.1 Atomic radius

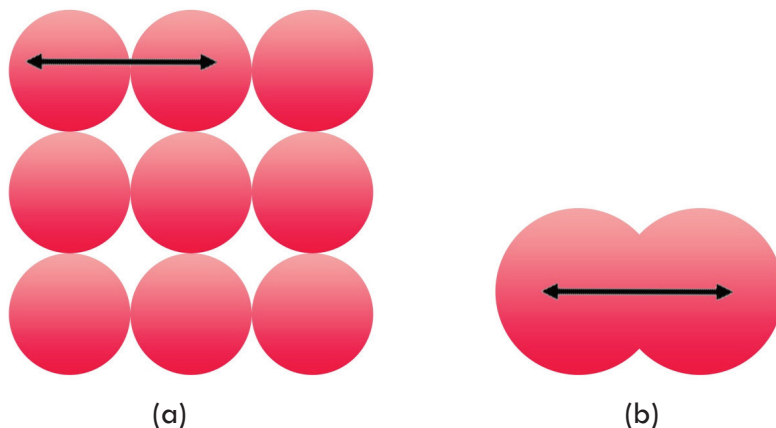


Form a group and perform the following task. Present your findings to the class.

By Referring **Figure 4.8** discuss in group what you observe on the trend in atomic radius and present your conclusion for the class.

A number of physical properties, including density, melting point, and boiling point, are related to the sizes of atoms, but atomic size is difficult to define. When we must be even more specific, we define the size of an atom in terms of its atomic radius, which is one-half the distance between the two nuclei in two adjacent metal atoms.

For atoms linked together to form an extensive three-dimensional network, atomic radius is simply one-half the distance between the nuclei in two neighbouring atoms [Figure 4.7(a)]. For elements that exist as simple diatomic molecules, the atomic radius is one-half the distance between the nuclei of the two atoms in a particular molecule [Figure 4.7(b)].



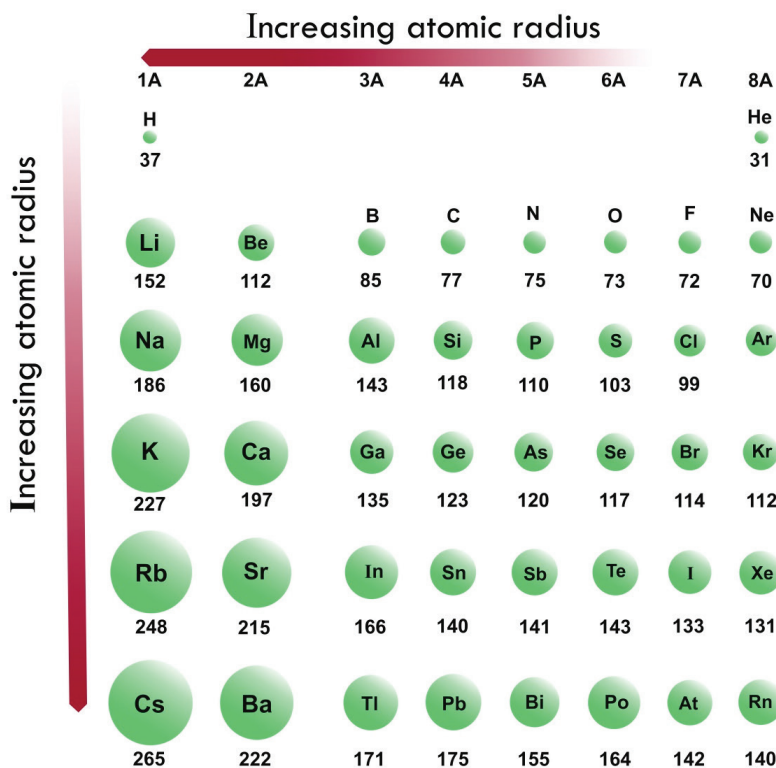
**Figure 4.7** (a) In metals such as beryllium, the atomic radius is defined as one-half the distance between the centers of two adjacent atoms. (b) For elements that exist as diatomic molecules, such as iodine, the radius of the atom is defined as one-half the distance between the centers of the atoms in the molecule.

**Figure 4.8** shows the atomic radii of many elements according to their positions in the periodic table, and **Figure 4.9** plots the atomic radii of these elements against their atomic numbers. Periodic trends are clearly evident. In studying the trends, bear in mind that the atomic radius is determined to a large extent by the strength of the attraction between the nucleus and the outer-shell electrons. Here the term effective nuclear charge instead of nuclear charge is used. Nuclear charge is the number of protons in the nucleus of an atom. Effective nuclear charge ( $Z_{\text{eff}}$ ) is the magnitude of positive charge “experienced” by an electron in the atom. The larger the effective nuclear charge, the stronger the hold of the nucleus on these electrons, and the smaller the atomic radius. Consider the second-period elements from Li to F, for example. Moving from left to right, we find that the number of electrons in the inner shell ( $1s^2$ ) remains constant while the nuclear charge increases.  $Z_{\text{eff}}$  increases from left to right across a period; changes very little down a column. The electrons that are added to counterbalance the increasing nuclear charge are ineffective in shielding one another. Consequently, the effective nuclear charge increases steadily while the principal quantum number remains constant ( $n=2$ ). For example, the outer  $2s$  electron in lithium is shielded from the nucleus (which has three protons) by the two  $1s$  electrons. As an

## Chemistry Grade 9

approximation, we assume that the shielding effect of the two 1s electrons is to cancel two positive charges in the nucleus. Thus, the 2s electron only feels the attraction of one proton in the nucleus; the effective nuclear charge is +1. In beryllium ( $1s^2 2s^2$ ), each of the 2s electrons is shielded by the inner two 1s electrons, which cancel two of the four positive charges in the nucleus. Because the 2s electrons do not shield each other as effectively, the net result is that the effective nuclear charge of each 2s electron is greater than +1. Thus, as the effective nuclear charge increases, the atomic radius decreases steadily from lithium to fluorine.

Within a group of elements we find that atomic radius increases with increasing atomic number. For the alkali metals in Group 1A, the outermost electron resides in the ns orbital. Because orbital size increases with the increasing principal quantum number n, the size of the metal atoms increases from Li to Cs even though the effective nuclear charge also increases. We can apply the same reasoning to the elements in other groups.



**Figure 4.8** Atomic radii (in picometers) of representative elements according to their positions in the periodic table. Note that there is no general agreement on the size of atomic radii. We focus only on the trends in atomic radii, not on their precise values.

### Example 4.4

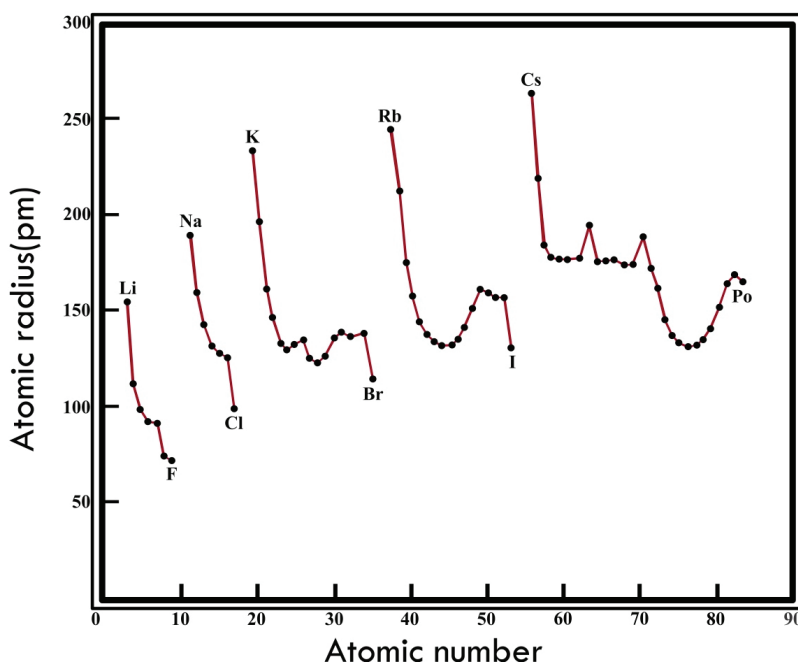
Referring to a periodic table, arrange the following atoms in order of increasing atomic radius: P, Si, N.

**Strategy** What are the trends in atomic radii in a periodic group and in a particular period? Which of the preceding elements are in the same group? in the same period? **Solution** From **Figure 4.8** we see that N and P are in the same group (Group VA). Therefore, the radius of N is smaller than that of P (atomic radius increases as we go down a group). Both Si and P are in the third period, and Si is to the left of P. Therefore, the radius of P is smaller than that of Si (atomic radius decreases as we move from left to right across a period). Thus, the order of increasing radius is  $N < P < Si$ .



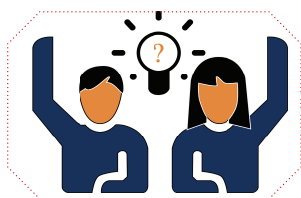
### Exercise 4.3

Arrange the following atoms in order of decreasing radius: C, Li, Be and give explanation to your arrangement



**Figure 4.9** Plot of atomic radii (in picometers) of elements against their atomic numbers.

### 4.4.2 Ionization Energy



#### Activity 4.6

Form a group and perform the following task. Present your findings to the class.

By Referring **Table 4.6** and **4.7** discuss in group what you observe on the trend in ionization energy and present your conclusion for the class.

## Chemistry Grade 9

Ionization energy is the quantity of energy that an isolated, gaseous atom in the ground electronic state must absorb to discharge an electron, resulting in a cation.

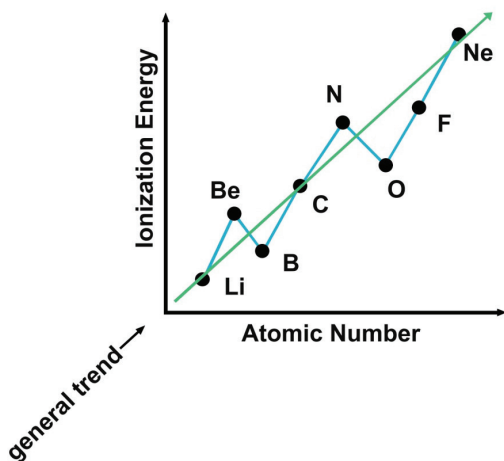


This energy is usually expressed in kJ/mol, or the amount of energy it takes for all the atoms in a mole to lose one electron each.

When considering an initially neutral atom, expelling the first electron will require less energy than expelling the second, the second will require less energy than the third, and so on. Each successive electron requires more energy to be released. This is because after the first electron is lost, the overall charge of the atom becomes positive, and the negative forces of the electron will be attracted to the positive charge of the newly formed ion. The more electrons that are lost, the more positive this ion will be, the harder it is to separate the electrons from the atom.

In general, the further away an electron is from the nucleus, the easier it is for it to be expelled. In other words, ionization energy is a function of atomic radius; the larger the radius, the smaller the amount of energy required to remove the electron from the outer most orbital. For example, it would be far easier to take electrons away from the larger element of Ca (Calcium) than it would be from one where the electrons are held tighter to the nucleus, like Cl (Chlorine).

As described above, ionization energies are dependent upon the atomic radius. Since going from right to left on the periodic table, the atomic radius increases, and the ionization energy increases from left to right in the periods and up the groups. Exceptions to this trend is observed for alkaline earth metals (Group IIA) and nitrogen group elements (Group VA). Typically, Group IIA elements have ionization energy greater than Group IIIA elements and group VA elements have greater ionization energy than group VIA elements. Groups IIA and VA have completely and half-filled electronic configuration respectively, thus, it requires more energy to remove an electron from completely filled orbitals than incompletely filled orbitals.



**Figure 4.10** Trend of ionization energy in kJ/mol of period 2 elements.





### Exercise 4.4

Rank each set of the following elements in order of decreasing ionization energy and explain the trend in ionization energy of the elements down a group.

- Ca, Sr, Mg, Be
- K, Li, Rb, Na
- Cl, F, I, Br

Alkali metals (Group IA) have small ionization energies, especially when compared to halogens or Group VIIA (see **Table 4.6**). In addition to the radius (distance between nucleus and the electrons in outermost orbital), the number of electrons between the nucleus and the electron(s) you're looking at in the outermost shell have an effect on the ionization energy as well. This effect, where the full positive charge of the nucleus is not felt by outer electrons due to the negative charges of inner electrons partially canceling out the positive charge, is called shielding. The more electrons shielding the outer electron shell from the nucleus, the less energy required to expel an electron from said atom. The higher the **shielding effect** the lower the ionization energy (see **Table 4.7**). It is because of the shielding effect that the ionization energy decreases from top to bottom within a group. From this trend, Cesium is said to have the lowest ionization energy and Fluorine is said to have the highest ionization energy (with the exception of Helium and Neon).

**Table 4.6** showing the increasing trend of ionization energy in kJ/mol (exception in case of Boron) from left to right in the periodic table

Li	Be	B	C	N	O	F
520	899	800	1086	1402	1314	1680

**Table 4.7** showing decreasing trend of ionization energies (kJ/mol) from top to bottom (Cs is the exception in the first group)

Element	Li	Na	K	Rb	Cs	Fr
Ionization energy	520	496	419	408	376	396

### Example 4.5

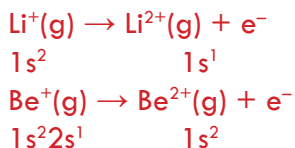
(a) Which atom should have a smaller first ionization energy: oxygen or sulfur?

(b) Which atom should have a higher second ionization energy: lithium or beryllium?

Strategy (a) First ionization energy decreases as we go down a group because the outermost electron is farther away from the nucleus and feels less attraction. (b) Removal of the outermost electron requires less energy if it is shielded by a filled inner shell.

**Solution** (a) Oxygen and sulfur are members of Group 6A. They have the same valence electron configuration ( $ns2np4$ ), but the 3p electron in sulfur is farther from the nucleus and experiences less nuclear attraction than the 2p electron in oxygen. Thus, we predict that sulfur should have a smaller first ionization energy.

(b) The electron configurations of Li and Be are  $1s^22s^1$  and  $1s^22s^2$ , respectively. The second ionization energy is the minimum energy required to remove an electron from a gaseous unipositive ion in its ground state. For the second ionization process we write



Because 1s electrons shield 2s electrons much more effectively than they shield each other, we predict that it should be easier to remove a 2s electron from  $\text{Be}^+$  than to remove a 1s electron from  $\text{Li}^+$

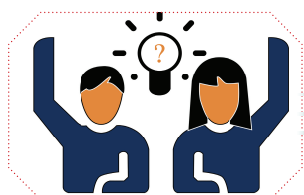


### Exercise 4.5

- Which of the following atoms should have a larger first ionization energy: N or P?
- Which of the following atoms should have a smaller second ionization energy: Na or Mg?

### 4.4.3 Electron Affinity

Electron affinity is defined as the change in energy (in kJ/mole) of a neutral atom (in the gaseous phase) when an electron is added to the atom to form a negative ion. In other words, the neutral atom's likelihood of gaining an electron.



#### Activity 4.7

Form a group and perform the following task. Present your findings to the class.

By Referring **Figure 4.11** discuss in group what you observe on the trend in electron affinity and present your conclusion for the class.

Energy of an atom is defined when the atom loses or gains energy through chemical reactions that cause the loss or gain of electrons. A chemical reaction that releases energy is called an exothermic reaction and a chemical reaction that absorbs energy is called **an endothermic reaction**. Energy from an exothermic reaction is negative, thus energy is given a negative sign; whereas, energy from an endothermic reaction is positive and energy is given a positive sign. An example that demonstrates both

processes is when a person drops a book. When he or she lifts a book, he or she gives potential energy to the book (energy absorbed). However, once the he or she drops the book, the potential energy converts itself to kinetic energy and comes in the form of sound once it hits the ground (energy released).

When an electron is added to a neutral atom (i.e., first electron affinity) energy is released; thus, the first electron affinities are **negative**. However, more energy is required to add an electron to a negative ion (i.e., second electron affinity) which overwhelms any the release of energy from the electron attachment process and hence, second electron affinities are **positive**.

☞ First Electron Affinity (negative energy because energy released):



☞ Second Electron Affinity (positive energy because energy needed is more than gained):



Ionization energies are always concerned with the formation of positive ions. Electron affinities are the negative ion equivalent, and their use is almost always confined to elements in Groups 6 and 7 of the Periodic Table. The first electron affinity is the energy released when 1 mole of gaseous atoms each acquire an electron to form 1 mole of gaseous  $-1$  ions. It is the energy released (per mole of  $X$ ) when this change happens. First electron affinities have negative values. For example, the first electron affinity of chlorine is  $-349 \text{ kJ mol}^{-1}$ . By convention, the negative sign shows a release of energy.

When an electron is added to a metal element, energy is needed to gain that electron (endothermic reaction). Metals have a less likely chance to gain electrons because it is easier to lose their valance electrons and form cations. It is easier to lose their valance electrons because metals' nuclei do not have a strong pull on their valance electrons. Thus, metals are known to have lower electron affinities.

#### Example 4.6 Group I Electron Affinities

This trend of lower electron affinities for metals is described by the Group I metals:

- ☞ Lithium (Li):  $-60 \text{ KJ mol}^{-1}$
- ☞ Sodium (Na):  $-53 \text{ KJ mol}^{-1}$
- ☞ Potassium (K):  $-48 \text{ KJ mol}^{-1}$
- ☞ Rubidium (Rb):  $-47 \text{ KJ mol}^{-1}$
- ☞ Cesium (Cs):  $-45 \text{ KJ mol}^{-1}$

**Notice that** electron affinity **decreases** down the group.

When nonmetals gain electrons, the energy change is usually negative because they give off energy to form an anion (exothermic process); thus, the electron affinity will be negative. Nonmetals have a greater electron affinity than metals because of their atomic structures: first, nonmetals have more valence electrons than metals do, thus it is easier for the nonmetals to gain electrons to fulfill a stable octet and secondly, the valence electron shell is closer to the nucleus, thus it is harder to remove an electron and it easier to attract electrons from other elements (especially metals). Thus, nonmetals have a higher electron affinity than metals, meaning they are more likely to gain electrons than atoms with a lower electron affinity.

### Example 4.7 Group VIIA Electron Affinities

For example, nonmetals like the elements in the halogens series in Group VIIA have a higher electron affinity than the metals. This trend is described as below. Notice the negative sign for the electron affinity which shows that energy is released.

- ☞ Fluorine (F)  $-328 \text{ kJ mol}^{-1}$
- ☞ Chlorine (Cl)  $-349 \text{ kJ mol}^{-1}$
- ☞ Bromine (Br)  $-324 \text{ kJ mol}^{-1}$
- ☞ Iodine (I)  $-295 \text{ kJ mol}^{-1}$

**Notice that** electron affinity decreases down the group, but increases across the period from left to right. But you can observe there is irregularity in electron affinity of fluorine and chlorine. Why is electron affinity of fluorine less than that of chlorine?

**Solution:** Electron affinity of fluorine is less than that of chlorine. This is due to the reason explained below:

Fluorine has seven electrons in 2p-subshell whereas chlorine has seven electrons in its 3p-subshell. 3p-subshell is relatively larger than 2p-subshell. Therefore, repulsion among the electrons will be more in the 2p-shell of fluorine than 3p-subshell in chlorine. Due to the smaller size and thus, the greater electron-electron repulsions, fluorine will not accept an incoming electron with the same as chlorine. As a result, a lesser amount of energy is released when one electron is added into the 2p-subshell of F (g) to form  $\text{F}^-$  (g) ion.



### Exercise 4.6

1. Why does the electron affinity of Cl is higher than that of F?
2. Explain why noble gases have extremely low (almost zero) electron affinities?
3. Explain why halogens have the highest electron affinities?

As the name suggests, electron affinity is the ability of an atom to accept an electron. Unlike electronegativity, electron affinity is a quantitative measurement of the energy change that occurs when an electron is added to a neutral gas atom. The more negative the electron affinity value, the higher an atom's affinity for electrons. **Figure 4.11** shows the electron affinity trend.

**Table 4.8** Showing the increasing trend of electron affinities in kJ/mol (exception in case of Beryllium and nitrogen) from left to right in the periodic table.

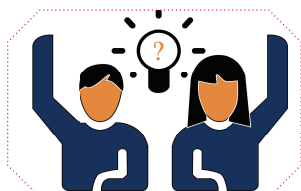
Element	Li	Be	B	C	N	O	F
Electron Affinity	-60	0	-27	-122	0	-141	-328

**Table 4.9** Showing decreasing trend of Electron affinities (kJ/mol) from top to bottom

Element	Li	Na	K	Rb	Cs
Electron Affinity	-60	-53	-48	-47	-45



### 4.4.4 Electronegativity



#### Activity 4.8

#### Electronegativity

Form a group and perform the following task. Present your findings to the class.

The following values are given for electronegativity of period 3 elements: 2.1, 0.9, 1.5, 3.0, 1.8, 2.5 and 1.2

Based on the information given;

1. Draw a table of period 3 elements and fill with the appropriate electronegativity values corresponding to the symbols of the elements.
2. Explain the reason for the observed trend.

The tendency of an atom in a molecule to attract the shared pair of electrons towards itself is known as electronegativity. It is a dimensionless property because it is only a tendency. It basically indicates the net result of the tendencies of atoms in different elements to attract the bond-forming electron pairs. We measure electronegativity on several scales. The most commonly used scale was designed by Linus Pauling. According to this scale, fluorine is the most electronegative element with a value of 4.0 and cesium is the least electronegative element with a value of 0.7.

As we move across a period from left to right the nuclear charge increases and the atomic size decreases, therefore the value of electronegativity increases across a period in the modern periodic table. There is an increase in the atomic number as we move down the group in the modern periodic table. The nuclear charge also increases but the effect of the increase in nuclear charge is overcome by the addition of one shell. Hence, the value of electronegativity decreases as we move down the group. For example, in the halogen group as we move down the group from fluorine to astatine the electronegativity value decreases.



#### Exercise 4.7

Arrange each set of the given elements in order of decreasing electronegativity and explain the observed trend.

- a. Ba, Mg, Be, Ca
- b. C, Pb, Ge, Si
- c. Cl, F, I, Br

It is a general observation that metals show a lower value of electronegativity as compared to the non-metals. Therefore, metals are electropositive and non-metals are electronegative in nature. The elements in period two differ in properties from their respective group elements (for example Li is different from Na, K, Rb, Cs and Fr) due

to the small size and higher value of electronegativity.

The elements in the second period show resemblance to the elements of the next group in period three. This happens due to a small difference in their electronegativities. This leads to the formation of a diagonal relationship (see section 4.2.2).

Elements requiring few electrons to complete their valence shells and having few inner electron shells between nucleus and valence electrons, are the most electronegative. The most electronegative of all elements is fluorine. Its electronegativity is 4.0. Metals have electronegativity less than 2.0. The least electronegative elements are cesium (Cs) and francium (Fr), with electronegativity values of 0.7. Therefore, Fluorine is the most electronegative element and cesium is the least electronegative element.

### Key Terms

☞ Atomic size	☞ Law of octaves
☞ Electron affinity	☞ Law of triads
☞ Electronegativity	☞ Lothar Meyer's curve
☞ Group	☞ Periodic law
☞ Ionization energy	☞ Period

### Unit Summary

- ☞ Nineteenth-century chemists developed the periodic table by arranging elements in the increasing order of their atomic masses. Discrepancies in early versions of the periodic table were resolved by arranging the elements in order of their atomic numbers.
- ☞ The elements can be arranged in rows and columns by atomic number to form the periodic table. Elements in a given group (column) have similar properties. (A period is a row in the periodic table.) Elements on the left and at the center of the table are metals; those on the right are nonmetals.
- ☞ Electron configuration determines the properties of an element. The modern periodic table classifies the elements according to their atomic numbers, and thus also by their electron configurations. The configuration of the valence electrons directly affects the properties of the atoms of the representative elements.
- ☞ Atomic radius varies periodically with the arrangement of the elements in the periodic table. It decreases from left to right and increases from top to bottom.
- ☞ Ionization energy is a measure of the tendency of an atom to resist the loss of an electron. The higher the ionization energy, the stronger the attraction between the nucleus and an electron.
- ☞ Electron affinity is a measure of the tendency of an atom to gain an electron. The more positive the electron affinity, the greater the tendency for the atom to gain an electron. Metals usually have low ionization energies, and nonmetals usually have high electron affinities.
- ☞ Noble gases are very stable because their outer ns and np subshells are completely filled.



- ☞ The metals among the representative elements (in Groups IA, IIA, and IIIA) tend to lose electrons until their cations become isoelectronic with the noble gases that precede them in the periodic table.
- ☞ The nonmetals in Groups VA, VIA, and VIIA tend to accept electrons until their anions become isoelectronic with the noble gases that follow them in the periodic table.
- ☞ The tendency of an atom in a molecule to attract the shared pair of electrons towards itself is known as electronegativity. It is a dimensionless property because it is only a tendency. It basically indicates the net result of the tendencies of atoms in different elements to attract the bond-forming electron pairs.

## Review Exercises

### Part I: Basic level questions.

Identify whether each of the following statements is true or false. Give your reasons when you consider a statement to be false.

1. The modern periodic law was proposed by Mosley.
2. Elements across a period have consecutive atomic numbers.
3. All elements with high ionization energy also have high electron affinity.
4. As the atomic number of elements increases in the periodic table, their atomic radius also increases.
5. Transition metals are found in four periods. Each corresponds to the filling of valence electrons in the 3d, 4d, 5d, and 6d orbitals.

### PART II: Intermediate level questions.

Given below are multiple choice questions. Choose the best answer from the given alternatives.

6. The periodic law states that
  - a. similar properties recur periodically when elements are arranged according to increasing atomic number
  - b. similar properties recur periodically when elements are arranged according to increasing atomic weight
  - c. similar properties are everywhere on the periodic table
  - d. elements in the same period have same characteristics
7. Which element is most similar to Sodium
 

a. Potassium	c. Oxygen
b. Aluminium	d. Calcium
8. Which element is most similar to Calcium?
 

a. Carbon	c. Strontium
b. Oxygen	d. Iodine

## Chemistry Grade 9

9. Who were the two chemists that came up with the periodic law?
- John Dalton and Michael Faraday
  - Dmitri Mendeleev and Lothar Meyer
  - Michael Faraday and Lothar Meyer
  - John Dalton and Dmitri Mendeleev
10. The statement that is not true about electron affinity is
- It causes energy to be released
  - It causes energy to be absorbed
  - It is expressed in electron volts
  - It involves formation of an anion
11. Which of the following is Dobereiner's triad?
- |                    |               |
|--------------------|---------------|
| a. Ne, Ca, Na      | c. Li, Na, K  |
| b. $H_2, N_2, O_2$ | d. Na, Br, Ar |
12. Write the period number, group number and block of the element having atomic number 42.
- |            |             |
|------------|-------------|
| a. 5, 5, d | c. 5, 2, d  |
| b. 5, 6, d | d. 5, 15, p |
13. X, Y and Z are three consecutive elements. X on addition of one electron and Y on addition of two electrons become isoelectronic with element Z. Which of the following is the correct property of Element Y?
- Atomic number of Y is higher than atomic number of Z.
  - Atomic number of Y is higher than atomic number of X.
  - Element Y is placed in periodic table at left side of element X if both are in same period.
  - None of these

**To which group, period, and sublevel block do the following elements belong?**

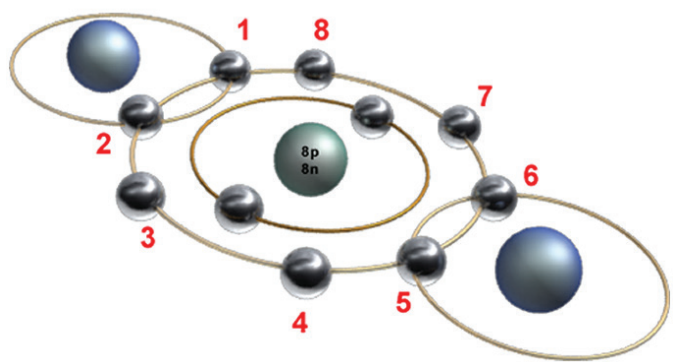
	Group	Period	Block type
Magnesium	_____	_____	_____
Phosphorous	_____	_____	_____
Krypton	_____	_____	_____
Manganese	_____	_____	_____
Gold	_____	_____	_____
Potassium	_____	_____	_____

### PART IIV: Challenge level questions.

Short Answer Type Questions. For the short answer questions below, give your responses.

- Briefly describe the significance of Mendeleev's periodic table.
- What is Moseley's contribution to the modern periodic table?
- Describe the general layout of a modern periodic table.
- What is the most important relationship among elements in the same group in the periodic table?

# UNIT 5



## CHEMICAL BONDING

### Unit Outcomes

After completing the unit, you will be able to

- ☞ discuss the formation of ionic, covalent and metallic bonds;
- ☞ explain the general properties of substances containing ionic, covalent and metallic bonds;
- ☞ develop the skills of drawing the electron dot or Lewis structures for simple ionic and covalent compounds;
- ☞ describe the origin of polarity within molecules.





### Start-up Activity

Students form groups and discuss on the following questions and present your discussion points to the class.

1. What held together the Sun and other planets?
2. Is it possible for human beings to survive in the absence of gravitational force?
3. Why do most substances not exist in their elemental form?

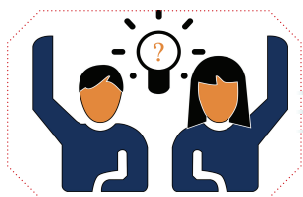


In Unit 3 we have discussed about the atomic structure. We have seen that a common atom contains a nucleus composed of protons and neutrons, with electrons in certain energy levels revolving around the nucleus. In this unit, the main focus will be on these electrons. Elements are distinguishable from each other due to their electrons. Because each element has a distinct number of electrons, this determines their chemical properties as well as the extent of their reactivity. In chemical bonding, only valence electrons, electrons located in the orbits of the outermost energy level (valence shell) of an element, are involved. The unit therefore deals with the way how the different types of chemical bonds are formed, the properties of compounds formed in each type of chemical bonding, and the formulas used to represent molecules or compounds formed in each type of chemical bonding.

## 5.1 Chemical Bonding

At the end of this section, you will be able to

- ☞ define chemical bonding
- ☞ describe why atoms form chemical bonds.



### Activity 5.1

Students, please form groups and discuss the following questions. Present your discussion points to the class.

1. Most of the elements are not found in their atomic form. Do you know why this is so?
2. What binds atoms together to form compounds or molecules?
3. Do you know how atoms combine to form compounds or molecules?

The material world in which we live is changing from time to time. This is due to the fact that nature is associated with innumerable chemical and physical changes. The chemical changes occur due to changes in the composition of the elements from which the materials are made of. We call these chemical changes, chemical reactions. As you

have learned in your grade 7 science a chemical reaction involves change in molecular composition of a substance. It has been established that atom is the smallest particle of matter which takes part in a chemical reaction. Molecule is the smallest constituent particle of substance which has an independent existence and which represents the properties of the respective elements or compounds.

### Why do atoms form chemical bond?

Most of the elements in nature have been found to exist in combined state. This is due to the fact that atoms of some elements are unstable by their own. There are, however, some atoms which have independent existence and are considered to be highly stable atoms. Except those of a few elements, the atoms of most of the elements have an inherent tendency to combine and form molecules or compounds. The combining atoms may belong to the same element or different elements. Within the molecules, the atoms are held together by attractive forces. A **chemical bond** is, therefore, the force that holds atoms together to form molecules or compounds.

### Octet Rule

The American chemist Gilbert Lewis (1875-1946) used this observation to explain the types of ions and molecules that are formed by other elements. He called his explanation the octet rule. The octet rule states that atoms tend to form compounds in ways that give them eight valence electrons, and thus the electron configuration of a noble gas (except helium).

In the preceding unit we have discussed about the valence electrons of the atoms of elements in each group in a periodic table. The valence electrons of all atoms are between 1 and 8. Most elements follow the octet rule in chemical bonding, which means that an element should have eight valence electrons in a bond or exactly fill up its valence shell. Having a total of eight valence electrons ensures that the atom is stable. This is the reason why noble gases, a valence electron shell of eight electrons, are chemically inert; they are already stable and tend to not need the transfer of electrons when bonding with another atom in order to be stable.

### How could atoms satisfy the Octet Rule?

There are three ways in which atoms can satisfy the octet rule.

- i. By losing valence electrons from an atom.
- ii. By gaining valence electrons from other elements.
- iii. By sharing their valence electrons with other atoms.

To become stable, atoms of metals tend to lose all of their valence electrons, which leave them with an octet. For example, sodium, an alkali metal has 11 electrons and its electronic configuration is 2,8,1. In order to fulfil the octet rule, sodium needs to lose its outermost electron and hence its electronic configuration will become 2,8.

Atoms of non-metals, on the other hand, tend to gain electrons in order to fill their

outermost principal energy level with an octet. For example, oxygen being a non-metallic element has a total of eight electrons. Its electronic configuration will be 2,6. To attain eight valence electrons, oxygen must gain two additional electrons in its valence shell. This, therefore, will change its electronic configuration to 2,8 which fulfils octet. Oxygen, however, can do this by sharing its two valence electrons with two electrons of another atom, which is known as sharing of electrons.



### Exercise 5.1

Provide appropriate answer to the following questions

1. What is the electronic configuration of a noble gas?
2. Why is the noble gas configuration important?
3. Define octet rule.
4. Do most elements follow the octet rule?
5. How does hydrogen violate the octet rule?

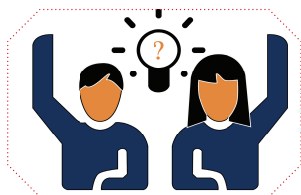
## 5.2 Ionic Bonding

In the preceding section, we have discussed that for atoms to become stable, they need to gain, lose or share their valence electrons. This losing, gaining or sharing of electrons by atoms leads to chemical bonding. The result of chemical bonding will be the formation of molecules or compounds having different chemical and physical properties. In this section, first, we are going to discuss the formation of ionic bonding. This will be followed by the discussion about how to write chemical formula of ionic compounds using the Lewis formula. The section will also cover the discussion of the properties of ionic compounds.

### 5.2.1 Formation of Ionic Bonding

At the end of this section, you will be able to

- ☞ explain the term ion;
- ☞ elucidate the formation of ions by giving examples;
- ☞ define ionic bonding;
- ☞ describe the formation of an ionic bond.



### Activity 5.2

Students, please form groups and discuss the following questions. Present your discussion points to the class.

1. What would happen to an atom when it gains or loses its valence electrons without combining with other atoms?
2. An electrically neutral atom has an equal number of negatively charged electrons and positively charged protons. What will happen to the charge of atom 'A' if it has one more electron than its protons and atom 'B' if it has one less electron number than its protons?
3. What type of force holds atoms "A" and "B" together (refer question number two)?

### What are Ions?

In unit three, we have seen that an atom is a basic unit of matter that consists of a dense nucleus composed of positively charged protons and neutral neutrons, which is surrounded by a cloud of negatively charged electrons. An atom possessing the same number of protons and electrons, is electronically neutral. However, if the total number of electrons does not equal the number of protons, the atom has a net positive or negative electrical charge.

Any atom or molecule with a net charge, either positive or negative, is known as an ion. The positive electric charge of a proton is equal in magnitude to the negative charge of an electron; therefore, the net electric charge of an ion is equal to its number of protons minus its number of electrons.

$$\text{Net electric charge} = \text{number of protons} - \text{number of electrons}$$

Ions are highly reactive species. They are generally found in a gaseous state, and do not occur in abundance on Earth. Ions in the liquid or solid state are produced when salts interact with their solvents. They are repelled by like electric charges but are attracted to opposite charges.

### Types of Ions

There are two types of the classifications of ions in chemistry. These include

- i. classification based on the type of electric charge atoms or group of atoms possess and
- ii. classification based on the number of atoms involved in ion formation.

## Chemistry Grade 9

In chemistry, we classify ions based on the type of electric charge of atoms. These are

- i. **Anions:** Are atoms or a group of atoms that have more electrons than protons and so have a net negative charge. Examples are  $\text{Cl}^-$ ,  $\text{I}^-$ ,  $\text{SO}_4^{2-}$ , and  $\text{NO}_3^-$ .
- ii. **Cations:** Are atoms or a group of atoms that have more protons than electrons and so have a net positive charge. Examples are  $\text{Na}^+$ ,  $\text{Ca}^{2+}$ , and  $\text{Al}^{3+}$ .

**Table 5.1** Cations and anions of some metallic and non-metallic elements.

Element	Proton	Electron	Charge	Representation	Proton	Electron	Ion
Hydrogen	1	1	0	H	1	0	$\text{H}^+$
Sodium	11	11	0	Na	11	10	$\text{Na}^+$
Magnesium	12	12	0	Mg	12	10	$\text{Mg}^{2+}$
Aluminium	13	13	0	Al	13	10	$\text{Al}^{3+}$
Nitrogen	7	7	0	N	7	10	$\text{N}^{3-}$
Oxygen	8	8	0	O	8	10	$\text{O}^{2-}$
Chlorine	17	17	0	Cl	17	18	$\text{Cl}^-$

### How Do Ions Form?

Ions can be formed by **ionization**, which is the process of a **neutral atom losing or gaining its valence electrons**. Generally, the electrons are either added to or lost from the valence shell of an atom; the inner-shell electrons do not participate in this type of chemical interaction. Ionization generally involves a transfer of electrons between atoms or molecules. The process is driven by the achievement of more stable electronic configurations, such as the octet rule. Polyatomic and molecular ions can also be formed, generally by gaining or losing elemental ions, such as  $\text{H}^+$ , in neutral molecules. Polyatomic ions are generally very unstable and reactive.

A common example of an ion is  $\text{Na}^+$  (read as sodium cation or ion). According to **Table 5.1**, sodium has a +1 charge when it contains ten electrons (neutral sodium has 11 electrons). However, according to the octet rule, sodium would be more stable with 10 electrons (2 in its innermost shell, 8 in its outermost shell). We have said that metals lose electrons in order to attain octet. Therefore, sodium metal tends to lose an electron to become more stable. On the other hand, chlorine, a non-metallic element tends to gain an electron to become  $\text{Cl}^-$  (read as chloride ion). Chlorine naturally has 17 electrons, but it would be more stable with 18 electrons (2 in its innermost shell, 8 in its second shell, and 8 in its valence shell). Therefore, chlorine will take an electron from another atom to become negatively charged. As a general rule, the charge of all group IA metals is 1+, group IIA metals is 2+, group VIIA nonmetals is -1. Group IIIA to VIA will not form an ionic bond in most cases, and they are not the topic of this section.



## Ionic Bonding

Let us consider the chemical bond that will be formed between sodium metal and chlorine. As we have discussed above, sodium will lose its outermost electron to attain octet and hence will become sodium cation ( $\text{Na}^+$ ; 2,8). Chlorine being a non-metal, accepts the electron sodium has lost and becomes a chloride ion ( $\text{Cl}^-$ , 2,8,8). When the two oppositely charged ions come together, they will be held together by an electrostatic force and result in the formation of sodium chloride ( $\text{NaCl}$ ), commonly known as table salt. A bond formed by two oppositely charged ions due to electrostatic force is known as an **ionic bond**. The process of forming such a bond is called **ionic bonding**. **Figure 5.2** shows the formation of an ionic bond between sodium and chlorine atoms using atomic diagrams.

There is another alternative for sodium and chlorine to attain the octet rule. Sodium, instead of losing its valence electron, needs to gain another seven electrons to its outermost shell in order to attain eight electrons on its valence shell. This, however, is very difficult to be achieved by sodium because metals tend to lose electrons. Secondly, gaining seven electrons needs a large amount of energy. Chlorine, on the other hand, is a non-metallic element that tends to gain electrons than losing its outermost electrons. If chlorine wants to achieve the octet rule by losing its seven valence electrons, which of course is the second option, it needs a large amount of energy. It is, therefore, easy for sodium to lose one electron than gaining seven extra electrons on its valence shell. It will be easy for chlorine to gain one electron than losing its seven valence electrons to fulfil the octet rule likewise.

Let us consider another example, the formation of an ionic bond between calcium and chlorine. Calcium with atomic number 20 has an electronic configuration of 2,8,8,2. In order to achieve octet, calcium removes its two valence electrons. This will make calcium a cation ( $\text{Ca}^{2+}$ ; 2,8,8) because the number of electrons is less by 2 than the number of protons. Chlorine as we have discussed above, needs only one electron to fulfil octet. The two electrons removed from calcium will, therefore, be received by two chlorine atoms to make two chloride ions ( $2\text{Cl}^-$ ). One calcium cation ( $\text{Ca}^{2+}$ ) will be attracted by the two chloride ions ( $2\text{Cl}^-$ ) resulting in calcium chloride ( $\text{CaCl}_2$ ). The atomic diagram in **Figure 5.3** depicts the ionic bond formation between calcium and chlorine.

As a general rule, ionic bond is formed between a metallic and a non-metallic elements. For atoms with the largest electronegativity differences (such as metals bonding with non-metals), the bonding interaction is called ionic, and the valence electrons are typically represented as being transferred from the metal atom to the non-metal. Once the electrons have been transferred to the non-metal, both the metal and the non-metal are considered to be ions. The two oppositely charged ions electrostatically attract each other to form an ionic compound.



## Exercise 5.2

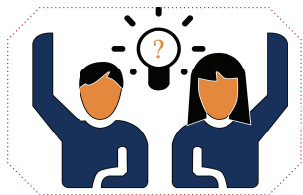
Provide the appropriate answer to the following questions.

1. Define the terms cation and anion.
2. How do cations and anions form?
3. What is a chemical bond?
4. How are ionic bonds formed?
5. An aluminium atom has three valence electrons. Do you think it will lose three electrons or gain five electrons to obtain an octet in its outermost electron shell? Why?
6. An iodine atom has seven valence electrons. Do you think it will lose seven electrons or gain one electron to obtain an octet in its outermost electron shell?
7. Describe the formation of potassium iodide.

### 5.2.2 Lewis Formulas of Ionic Compounds

At the end of this section, you will be able to

- ☞ give examples of simple ionic compounds;
- ☞ draw Lewis structures or electron-dot formulas of simple ionic compounds.



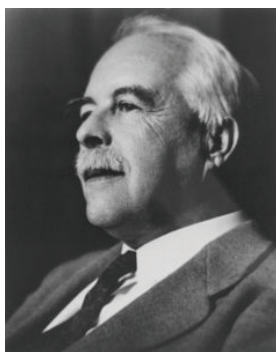
### Activity 5.3

Students, please form groups and discuss the following questions. Present your discussion points to the rest of the class.

1. What would you do to describe an orange for a person who has never seen orange in his/her entire life?
2. Why is it important to have a common way of representing substances?
3. Why do you think it is important to use a common formula of ionic compounds?

### Lewis Dot Formula

To explain the various types of bonds and to visualise the change in the valence electrons, the American physical chemist Gilbert N. Lewis (1916) proposed the Lewis dot formula.



**Figure 5.1** Picture of the American Physical Chemist Gilbert N. Lewis (1875-1046).

In the Lewis symbol for an atom, the chemical symbol of the element with their valence electrons is represented as dots surrounding it. Only the electrons in the valence level are shown using this notation. The number of dots equals the number of valence electrons in the atom. These dots are arranged to the right and left and above and below the symbol, with no more than two dots on a side (**Table 5.2**).

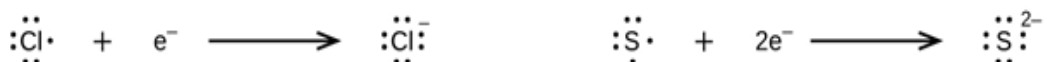
**Table 5.2** The Lewis symbols for the elements of the third period of the periodic table.

Atoms	Electronic Configuration	Lewis Symbol
sodium	$[\text{Ne}]3s^1$	$\text{Na} \cdot$
magnesium	$[\text{Ne}]3s^2$	$\cdot\text{Mg}\cdot$
aluminum	$[\text{Ne}]3s^23p^1$	$\cdot\overset{\cdot}{\text{Al}}\cdot$
silicon	$[\text{Ne}]3s^23p^2$	$\cdot\overset{\cdot}{\underset{\cdot}{\text{Si}}}\cdot$
phosphorus	$[\text{Ne}]3s^23p^3$	$\cdot\overset{\cdot}{\underset{\cdot}{\underset{\cdot}{\text{P}}}}\cdot$
sulfur	$[\text{Ne}]3s^23p^4$	$\cdot\overset{\cdot}{\underset{\cdot}{\underset{\cdot}{\underset{\cdot}{\text{S}}}}}\cdot$
chlorine	$[\text{Ne}]3s^23p^5$	$\cdot\overset{\cdot}{\underset{\cdot}{\underset{\cdot}{\underset{\cdot}{\underset{\cdot}{\text{Cl}}}}}}\cdot$
argon	$[\text{Ne}]3s^23p^6$	$\cdot\overset{\cdot}{\underset{\cdot}{\underset{\cdot}{\underset{\cdot}{\underset{\cdot}{\underset{\cdot}{\text{Ar}}}}}}}\cdot$

Lewis symbols can also be used to illustrate the formation of cations from atoms, for sodium and calcium as shown below:



Likewise, they can be used to show the formation of anions from atoms, as shown below for chlorine and sulphur:

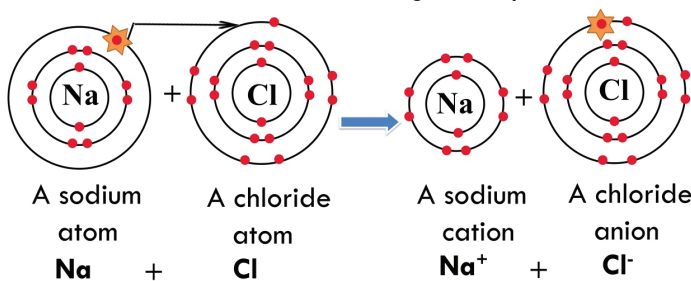


## Chemistry Grade 9

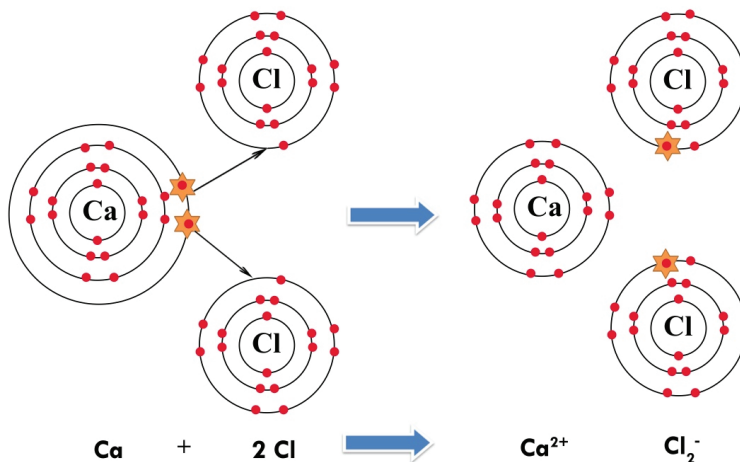
**Table 5.3** Lewis symbols showing the transfer of electrons during the formation of ionic compounds.

Metal		Nonmetal		Ionic Compound
Na •	+	: $\ddot{\text{Cl}}$ •	→	Na <sup>+</sup> [ $\ddot{\text{Cl}}$ ] <sup>-</sup> sodium chloride (sodium ion and chloride ion)
•Mg•	+	: $\ddot{\text{O}}$ •	→	Mg <sup>2+</sup> [ $\ddot{\text{O}}$ ] <sup>2-</sup> magnesium oxide (magnesium ion and oxide ion)
•Ca•	+	2 : $\ddot{\text{F}}$ •	→	Ca <sup>2+</sup> [ $\ddot{\text{F}}$ ] <sub>2</sub> <sup>-</sup> calcium fluoride (calcium ion and two fluoride ions)

Some examples of the Lewis dot formulas of ionic compounds are shown in **Table 5.3**. The Lewis dot formula can also be represented using the atomic diagram as shown in **Figures 5.2** and **5.3**. The dots on the atomic diagram represent the electrons.



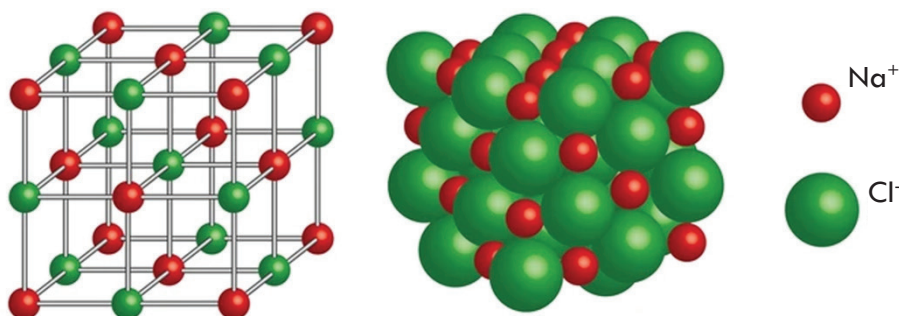
**Figure 5.2** An atomic diagram showing the formation of ionic compound (NaCl) between the atoms of sodium and chlorine.



**Figure 5.3** An atomic diagram showing ionic compound ( $\text{CaCl}_2$ ) formation between calcium and chlorine.



ions, not molecules. The opposite charged ions in ionic compounds are held together very strongly by electrostatic force of attraction. Hence the ionic compounds are generally hard solids. At an atomic level, an ionic crystal forms a regular structure, with the cation and anion alternating with each other and forming a three-dimensional structure-based, largely, on the smaller ion uniformly filling in the empty spaces between the larger ions (**Figure 5.4**).



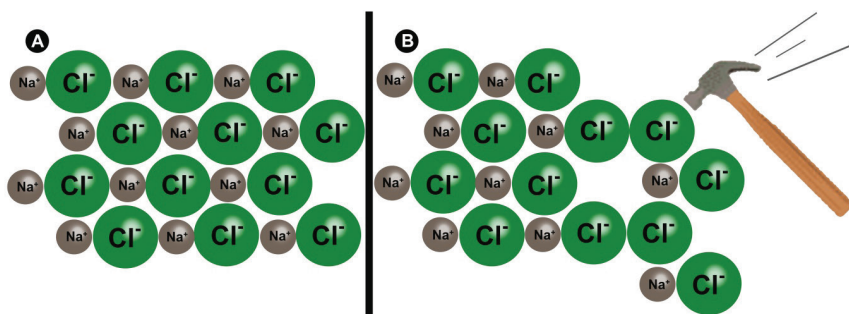
**Figure 5.4** The crystal structure of sodium chloride (NaCl).

### **They have high Melting Points and High Boiling Points.**

Considerable heat energy is required to separate the strong electrostatic attraction force between the positive and negative ions in ionic compounds. Therefore, a high temperature is required to melt and boil ionic compounds. The process of melting an ionic compound requires the addition of large amounts of energy in order to break all of the ionic bonds in the crystal and let the ions move freely. For example, breaking the ionic bonds in sodium chloride to make it melt requires a temperature of about  $800^\circ\text{C}$ . We call this temperature, melting point. It requires a very high temperature-  $1465^\circ\text{C}$  to boil sodium chloride. Boiling a substance means converting its constituents into a gaseous form.

### **They are Hard and Brittle**

Ionic crystals are hard because the positive and negative ions are strongly held together by electrostatic attraction force. It takes a large amount of mechanical force, such as striking a crystal with a hammer, to force one layer of ions to shift relative to its neighbour. Such striking brings ions of the same charge next to one another (**Figure 5.5**). The strong repulsive forces between like-charged ions cause the crystal to break. The property of being hard but liable to be broken is known as brittleness.



**Figure 5.5** Appearance of sodium chloride crystal before and after hitting.

The sodium chloride crystal is shown in two dimensions (**Figure 5.5**, left). When struck by a hammer, the negatively-charged chloride ions are forced near one another and the repulsive force causes the crystal to shatter (**Figure 5.5**, right).

### They are Soluble in Polar Solvents

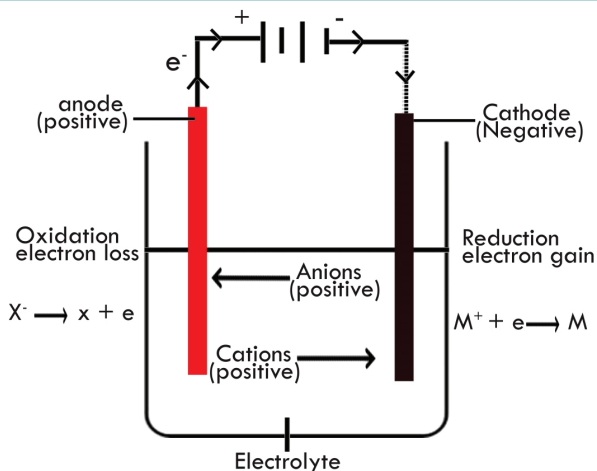
The solubility of a substance is the maximum amount of solute that can dissolve in a given quantity of solvent. Solubility depends on the chemical nature of both the solute and the solvent, and the temperature and pressure. One way of classifying solvents is into polar and non-polar. Polar solvents dissolve polar compounds and non-polar solvents dissolve non-polar compounds. This is commonly referred to as “like dissolves like”. A polar solvent is a type of solvent that has large partial charges. Water, methanol, liquid ammonia, liquid hydrogen fluoride, acetone and ethanol are common examples of polar solvent. There are, however, several ionic compounds that are insoluble in water. Most salts of carbonates, oxalates, phosphates, sulphides and hydroxides are insoluble in water.

### They Conduct Electricity when they are Dissolved in Water or in Molten State

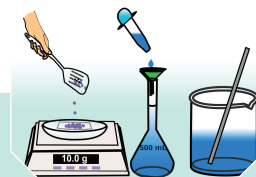
Melting and dissolving ionic compounds makes cations and anions free to move. Since the ions are free charged particles, they move towards the respective electrodes under the influence of electric field and conduct electricity through the solution. Molten ionic compounds also conduct electricity. For example: sodium chloride (NaCl) in its molten state releases sodium cation (Na<sup>+</sup>) and chloride anion (Cl<sup>-</sup>) as shown below:



In an electrolytic cell, the sodium cation moves to the negative electrode (cathode), and the chloride anion moves towards the positive electrode (anode). This causes complete movement of charge across the circuit.



**Figure 5.6** In an ionic solution, the  $A^+$  ions migrate toward the negative electrode, while the  $B^-$  ions migrate toward the positive electrode.



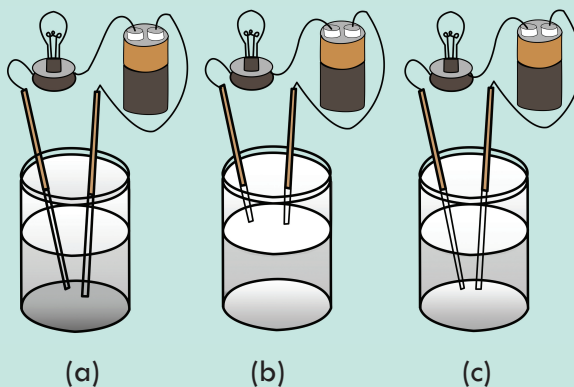
### Experiment 5.1 Conductivity of Ionic Compounds

**Objective:** In this experiment, we are going to see whether a distilled water, solid table salt (NaCl) or a water solution of table salt conduct electricity or not.

**Materials:** Distilled water (100 mL), table salt (60 g), three 25 mL beakers, battery, copper wire, two pieces of metallic rods or graphite rod, small electric bulb.

#### Procedure:

1. Take a 25 mL beaker and add 15 mL distilled water.
2. Take 20 g table salt (NaCl) and add it into the second beaker.
3. Dissolve 30 g of table salt (NaCl) in 50 mL distilled water. Add 25 mL of the solution into the third 25 mL beaker.
4. Assemble each of the beakers as shown in **Figure 5.7** below, turn by turn and see what happens to the electric bulb in each case.



**Figure 5.7** A) Distilled water; B) Solid table salt; C) A water solution of table salt.



**Observation and analysis questions**

Provide answers to the following questions based on the above experiment.

1. In which case did the electric bulb light?
2. Why the electric bulb did not light in the other two cases?
3. What do you conclude from this observation?

**They Have High Density**

The density of a substance is the amount of a substance per unit volume. It is one of the physical properties by which substances differ. The oppositely charged ions in an ionic compound are held closely by the electrostatic force of attraction. Hence, the number of ions per unit volume in an ionic compound is high, which in turn makes their density high.

**Exercise 5.4**

Provide appropriate answers to the following questions

1. State the five general properties of ionic compounds.
2. Why do ionic compounds form crystals?
3. If a compound dissolves in water, will it be a proof for the ionic nature of the compound? Why?
4. Why that ionic compounds do conduct electricity in the molten state or when dissolved in water but not in the solid- state?

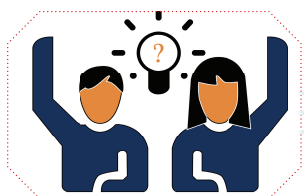
**5.3 Covalent Bonding**

We have thoroughly discussed that in order to become stable, atoms of elements need to fulfil the octet rule. Except for the noble gases, all the second row elements obey the octet rule either by gaining, losing or sharing electrons. In the preceding section, we have seen how atoms become stable by losing and gaining electrons. In this section, we shall discuss the second type of bonding known as **covalent bonding**, the Lewis dot formulas of covalent molecules, polarity in covalent molecules, coordinate covalent bond, and general properties of covalent compounds.

**5.3.1 Formation of Covalent Bond**

At the end of this section, you will be able to

- ☞ define covalent bonding;
- ☞ describe the formation of a covalent bond.



### Activity 5.5

Students, please form groups and discuss the following questions. Present a summary of your discussion points to the class.

1. An ionic bond is an electrostatic attraction force between a cationic and an anionic species. Is there another way through which two non-metallic atoms form a bond?
2. What kind of force holds the atoms together in compounds other than ionic?
3. How do the molecules  $H_2$ ,  $O_2$ ,  $HCl$ , and  $H_2S$  form?

A covalent bond consists of the simultaneous attraction of two nuclei for one or more pairs of electrons. In other words, a covalent bond is formed when two atoms share one or more electron pairs. The electrons residing between the two nuclei are known as the bonding electrons. In this type of bond, each shared electron will be counted by both atoms' valence shells in order to satisfy the octet rule. Based on the number of pairs of shared electrons, the covalent bonds formed can be classified into three:

- Single bond:** one pair of electrons is shared
- Double bond:** share two pairs of electrons and
- Triple bond:** share three pairs of electrons.

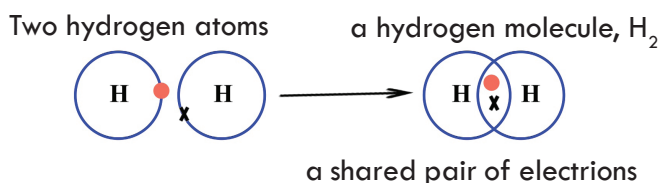
Generally, bonds sharing more than one pair of electrons are called **multiple covalent bonds**. Covalent bonds occur between identical atoms or between different atoms whose difference in electronegativity is insufficient to allow the transfer of electrons to form ions.

#### Formation of Single Covalent Bond

Let's consider the covalent bond in the hydrogen molecule ( $H_2$ ). A hydrogen molecule is formed from two hydrogen atoms, each with one electron in its valence shell. The two hydrogen atoms are attracted to the same pair of electrons in the covalent bond. The bond is represented either as a pair of "dots" or as a solid line. Each hydrogen atom acquires a helium-like electron configuration. Such a type of bond is known as a single bond (**Figure 5.8**).

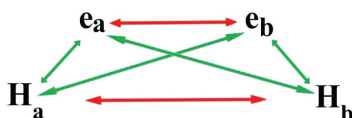


The alternative way of showing the above covalent bond formation would be the following:



**Figure 5.8** Atomic diagram showing the formation of covalent bond in hydrogen molecule ( $H_2$ ).

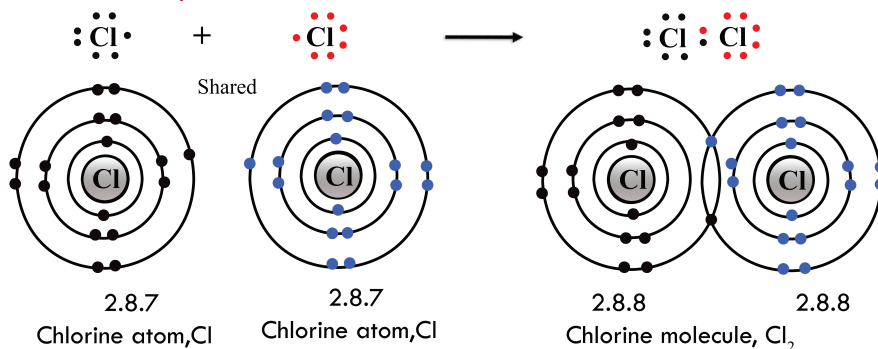
There exists an attraction force between the positively charged nuclei and the negatively charged bonding electrons, but there is also a repulsive force between the two positively charged nuclei as well as between the two negatively charged electrons. **Figure 5.9** shows these attractive and repulsive forces between the two hydrogen atoms.



**Figure 5.9** A scheme showing the nuclei-shared electron attractive forces (green double arrow) and the electron-electron and nucleus-nucleus repulsive forces (red double arrow).  $e_a$  and  $e_b$  are electrons of  $H_a$  and  $H_b$  respectively.

The attractive forces are equal in magnitude, but opposite in sign. Each hydrogen nucleus attracts both electrons. The net result is that the energy of the molecule becomes less than the atomic energies when the bond forms.

The two chlorine atoms in the chlorine molecule ( $Cl_2$ ) are joined by a shared pair of electrons. Each chlorine atom contains seven valence electrons in the valance shell and requires one more electron to form an argon-like electron configuration and become stable (**Figure 5.10**). The two chlorine atoms achieve this if each chlorine atom contributes one electron to the bonding pair shared by the two atoms. The remaining six valence electrons of each chlorine atom are not involved in bond formation and are located around their respective atoms. These valence electrons, normally shown as pairs of electrons, are commonly known as **non bonding electrons, lone pair electrons, or unshared electron pairs**.



**Figure 5.10** Atomic diagram showing formation of chlorine molecule ( $Cl_2$ ).

Single covalent bonds can also occur between two different atoms. For example, hydrogen sulphide ( $H_2S$ ) is formed when two hydrogens, each share their valence shell electrons to one sulphur atom. Sulphur is a group VIA element and it has 6 valence electrons. In order to fill its outermost shell with eight electrons, it needs two more electrons, in this case, two valence electrons shared by the two hydrogens. The two hydrogens will have an electronic configuration similar to that of helium which makes

## Chemistry Grade 9

them stable enough (the duet rule) whereas the sulphur atom will attain the electronic configuration of argon that makes it stable.



### Exercise 5.5

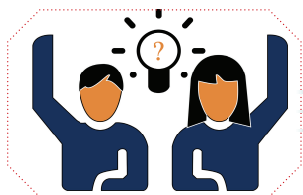
Provide appropriate answers to the following questions.

1. Define a covalent bond.
2. Why the nuclei of the two covalently bonded atoms do not collide during the formation of a covalent bond?
3. In covalently bonded atoms, what holds the two atoms together?
4. Describe the formation of  $\text{H}_2\text{O}$ ,  $\text{F}_2$ ,  $\text{CF}_4$ , and  $\text{NH}_3$ .

### Formation of Multiple Covalent Bonds

Students, please form groups and discuss the following questions. Present your discussion points to the class.

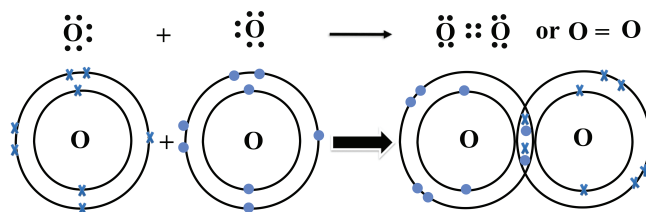
1. Is there another possible way through which two atoms or groups of atoms form a covalent bond other than a single bond?
2. Atom "A" has a total of eight electrons and atom "B" has a total of seven electrons. How do  $\text{A}_2$  and  $\text{B}_2$  form?
3. What do you call the covalent bond formed in  $\text{A}_2$  and  $\text{B}_2$ ?
4. Can you construct a model that shows  $\text{A}_2$  and  $\text{B}_2$ , from locally available materials?



### Activity 5.6

### Formation of Double Bond

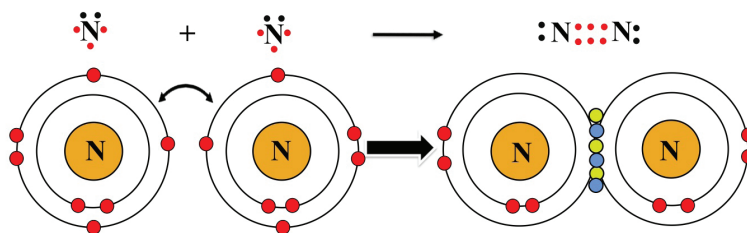
An oxygen molecule would be a good example for a double covalent bond formation. Atmospheric air consists of 21% of life-giving gas known as oxygen. Oxygen is a group VIA element with 6 valence electrons. Each oxygen atom requires two electrons to fulfil the octet rule. The two oxygen atoms, therefore, need to share two electrons each so that they could attain the nearest noble gas electronic configuration, neon. Since two pairs of electrons are shared between the two oxygen atoms in an oxygen molecule, such a type of bond is known as a double bond. The four pairs of electrons that do not participate in bonding and are situated on the two oxygens atoms in  $\text{O}_2$  are the lone pair electrons (**Figure 5.11**).



**Figure 5.11** Atomic diagram that shows formation of oxygen molecule ( $O_2$ ).

### Formation of Triple Covalent Bond

Nitrogen is a group VA element. It has 5 valence electrons. We know that 78% of the atmosphere is filled with the element nitrogen. Nitrogen exists in its molecular form which will not be stable, otherwise. This stability could be achieved by fulfilling the octet rule. To do so each nitrogen atom shares three electrons each to have the nearest noble gas (neon) electronic configuration which makes it stable. The sharing of three pairs of electrons in a covalent bond results in a triple bond. The pairs of electrons on the valence shells of the two nitrogen atoms in the  $N_2$  are the lone pair electrons (**Figure 5.12**).



**Figure 5.12** Atomic diagram of the formation of nitrogen molecule ( $N_2$ ).



### Exercise 5.6

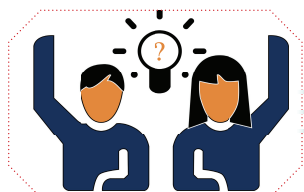
Provide appropriate answer to the following questions.

1. How many different types of covalent bonds have you known so far?
2. Describe the formation of carbon dioxide ( $CO_2$ ), ethylene ( $H_4C_2$ ), and acetylene ( $H_2C_2$ ) molecules.

### 5.3.2 Lewis's Formula of Covalent Molecules

At the end of this section, you will be able to

- ☞ draw Lewis structures or electron-dot formulas of simple covalent molecules;
- ☞ give examples of different types of covalent molecules;
- ☞ make models of covalent molecules show single, double and triple bonds using sticks and balls or from other locally available materials.



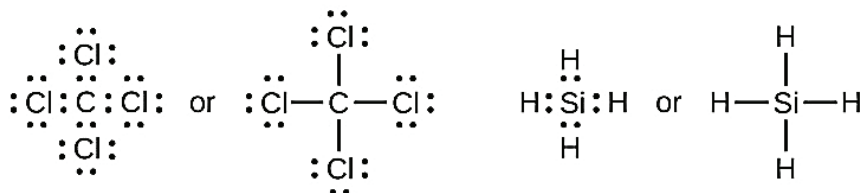
### Activity 5.7

Students, please form groups and discuss the following questions. Present your discussion points to the class.

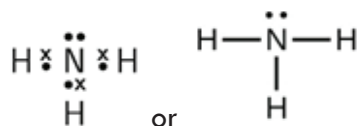
1. In the previous section, we discussed writing Lewis's formulas of ionic compounds. How can one write Lewis's formula of a covalent molecule?
2. Using the same analogy, write the Lewis formulas of the covalent molecule HCN.
3. How many bonding and lone pair electrons are there in HCN?
4. How many single, double and triple covalent bonds are there in HCN?

In section 5.2.2, we discussed about Lewis's formula of ionic compounds. We also used Lewis's formula to indicate the formation of covalent bonds, which are shown in Lewis structures, drawings that describe the bonding in molecules.

The number of bonds that an atom can form can often be predicted from the number of electrons needed to reach an octet. This is especially true of the non-metals of the second period of the periodic table (C, N, O, and F). For example, each atom of group IVA element has four electrons in its outermost shell and therefore requires four more electrons to reach an octet. These four electrons can be gained by forming four covalent bonds, as illustrated below for carbon in  $\text{CCl}_4$  (carbon tetrachloride) and silicon in  $\text{SiH}_4$  (silane). Because hydrogen only needs two electrons to fill its valence shell (duat rule), it is an exception to the octet rule.



Group VA elements such as nitrogen have five valence electrons in the atomic Lewis symbol: one lone pair and three unpaired electrons. To achieve an octet, these atoms form three covalent bonds, as in  $\text{NH}_3$  (ammonia).



Oxygen and other atoms in group VIA achieve an octet by forming two covalent bonds. For very simple molecules, we can write the Lewis structures by merely pairing up the unpaired electrons on the constituent atoms. Look at these examples in **Table 5.5**.

**Table 5.5** Lewis's formula of some simple covalent molecules.

Element/molecule	Dot formula	Line formula
Hydrogen	H:H	H—H
Nitrogen	:N:::N:	:N≡N:
Oxygen	$\begin{array}{c} \ddot{\text{O}} \\ \vdots \\ \ddot{\text{O}} \end{array} : \begin{array}{c} \ddot{\text{O}} \\ \vdots \\ \ddot{\text{O}} \end{array}$	:Ö=Ö:
Chlorine	:Cl : Cl:	:Cl—Cl:
Water	H:Ö:H	H—Ö—H
Ethene	$\begin{array}{c} \text{H} \cdot \quad \cdot \text{H} \\ \cdot \quad \cdot \\ \text{H} \cdot \text{C} :: \text{C} \cdot \text{H} \\ \cdot \quad \cdot \end{array}$	$\begin{array}{c} \text{H} \quad \quad \text{H} \\ \diagdown \quad \diagup \\ \text{C} = \text{C} \\ \diagup \quad \diagdown \\ \text{H} \quad \quad \text{H} \end{array}$
Acetylene	H:C:::C:H	H—C≡C—H
Formaldehyde	$\begin{array}{c} \cdot \quad \cdot \\ \cdot \quad \cdot \\ \text{H} : \text{C} : \text{H} \\ \cdot \quad \cdot \end{array}$	$\begin{array}{c} \text{H} \\ \diagdown \\ \text{C} = \ddot{\text{O}} \\ \diagup \\ \text{H} \end{array}$

**Exercise 5.7**

Provide the appropriate answer to the following questions.

- Write the Lewis structure for the diatomic molecule  $\text{P}_2$ , an unstable form of phosphorus found in high-temperature phosphorus vapor.
- Write Lewis structures for the following:
  - $\text{O}_2$
  - $\text{H}_2\text{CO}$
  - $\text{AsF}_3$
- Construct models for  $\text{CH}_4$ ,  $\text{O}_2$ ,  $\text{N}_2$ ,  $\text{H}_2\text{C}_2$  molecules from locally available materials.

**5.3.3 Polarity in Covalent Molecules**

At the end of this section, you will be able to

- ☞ discuss the polarity in covalent molecules;
- ☞ distinguish between polar and non-polar covalent molecules.



### Activity 5.8

Students, please form groups and discuss the following questions. Present your discussion points to the class.

1. Why is table salt soluble in water but not in oil?
2. What does electronegativity difference do to the electron distribution of atoms that are covalently bonded?
3. What would be the electron distribution of a covalent bond formed from two atoms having similar electronegativities?

The existence of a 100% ionic or covalent bond represents an ideal situation. In reality no bond or a compound is either completely covalent or ionic. Even in case of covalent bond between two diatomic molecules, there is some ionic character.

When covalent bond is formed between two similar atoms, for example in  $H_2$ ,  $O_2$ ,  $Cl_2$ ,  $N_2$  or  $F_2$  the shared pair of electrons is equally attracted by the two atoms. As a result electron pair is situated exactly between the two identical nuclei. The bond so formed is called nonpolar covalent bond. Contrary to this in case of a heteronuclear molecule like HF, the shared electron pair between the two atoms gets displaced more towards fluorine since the electronegativity of fluorine (as you have learned in unit 4) is far greater than that of hydrogen. The resultant covalent bond is a polar covalent bond.

### Nonpolar Covalent Molecules

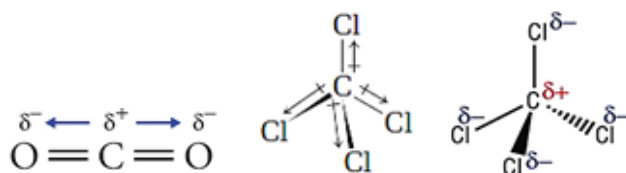
Let us consider the **homonuclear diatomic molecule  $H_2$** . In a molecule like  $H_2$ , in which the atoms are identical, we expect the electrons to be equally distributed between the two atoms. The two hydrogens have equal electronegativity (2.1), and the difference between the electronegativities will be zero. Therefore, according to the guideline, the covalent bond in  $H_2$  is non-polar. Generally, all homoatomic molecules like  $O_2$ ,  $N_2$ ,  $Cl_2$  are non-polar covalent molecules.

Let us consider the **heteronuclear polyatomic molecule ethane ( $C_2H_6$ )**. There are two different types of covalent bonds in ethane i.e., H-C and C-C. Considering the above guideline, the electronegativity value difference between hydrogen (2.1) and carbon (2.5) will be 0.4, which is below the minimum value for a polar covalent bond. The C-C bond is non-polar because there is no electronegativity value difference between the two carbons. Hence, ethane is a nonpolar covalent molecule.

Other examples of non-polar molecules include any of the homonuclear diatomic elements ( $H_2$ ,  $N_2$ ,  $O_2$ ,  $Cl_2$  which are truly non-polar molecules), carbon dioxide ( $CO_2$ ), benzene ( $C_6H_6$ ), carbon tetrachloride ( $CCl_4$ ), methane ( $CH_4$ ), ethylene ( $C_2H_4$ ), hydrocarbon liquids (gasoline and toluene), and most organic molecules.



Non-polar molecules also form when atoms sharing a polar bond arrangement such that the electric charges cancel out each other. For example, in  $\text{CO}_2$  and  $\text{CCl}_4$  the individual C-O and C-Cl bonds are polar. This is because, in the case of C-O bond the electronegativity value difference between carbon (2.5) and oxygen (3.5) is 1.0. Hence, the bond is polar. Similarly, in C-Cl bond the electronegativity value difference between carbon (2.5) and chlorine (3.0) is 0.5, which is the minimum value requirement for a polar covalent bond. However, in  $\text{CO}_2$  the molecular structure is linear  $\text{O}=\text{C}=\text{O}$  and the charges on the two oxygen atoms cancel out each other as they are oriented in the opposite directions (see below) making the molecule non-polar. In the case of  $\text{CCl}_4$ , the chlorines arrange themselves in a tetrahedral geometry (see below) around the carbon atom, and each partial charge on the four chlorine atoms will cancel out each other. This made  $\text{CCl}_4$  a nonpolar covalent molecule.



### Polar Covalent Molecules

In many covalent bonds the electrons are not shared equally between two bonded atoms. For example, in hydrogen chloride the electrons are unevenly distributed between the two atoms because the atoms that share the electrons in the molecule are different and have different electronegativities. Electronegativity is the tendency of an atom to pull bonding electrons toward it. A bond in which electrons are shared unevenly is called a polar bond or polar covalent bond. A polar bond has a slight positive charge on one end and a slight negative charge on the other end. The greater the difference in electronegativity between the bonded atoms, the more polar the bond will be. The direction of bond polarity can be indicated with an arrow. The head of the arrow is at the negative end of the bond; a short perpendicular line near the tail of the arrow marks the positive end of the bond.



A polar molecule is a molecule containing polar bonds where the sum of all the partial charges is not zero. Polar bonds form when there is a difference between the electronegativity values of the atoms participating in a bond. Polar molecules also form when the spatial arrangement of chemical bonds leads to a more positive charge on one side of the molecule than the other.

The HCl bond and other polar bonds can be thought of as being intermediate between a non-polar covalent bond, in which the sharing of electrons is exactly equal, and an ionic bond, in which the transfer of the electron(s) is nearly complete.





### Exercise 5.8

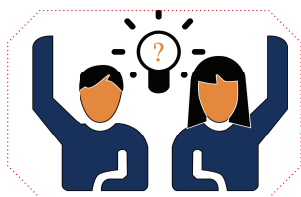
Provide the appropriate answer to the following questions.

1. Which of the following bonds is nonpolar covalent, which is polar covalent, and which is ionic? (a) the bond in CsCl, (b) the H-N bond in  $\text{NH}_3$ , (c) the NN bond in  $\text{H}_2\text{NNH}_2$ .
2. Explain your answers to question number 1.
3. Explain why  $\text{CO}_2$  is non-polar whereas  $\text{SO}_2$  is polar covalent bond?

### 5.3.4 Coordinate Covalent Bond (Dative Bond)

At the end of this section, you will be able to

- ☞ define coordinate covalent (dative) bond;
- ☞ elucidate the formation of a coordinate covalent bond using suitable examples.



### Activity 5.9

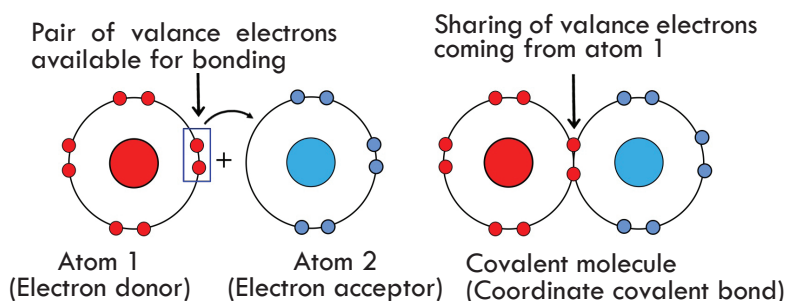
Students, please form groups and discuss the following questions. Present your discussion points to the class.

1. The cost of a “doro wet” meal in a certain hotel is 80 Birr. Person “A” has 200 Birr in his/her pocket and he/she bought three “doro wet” by sharing 40 Birr with his/her friends. The same day evening he/she met with his/her friend in the evening and wanted to eat dinner with him/her. Unfortunately, person “A” and his/her friend became hungry and wanted to eat dinner. Person “A”’s friend, however, had no money in his/her pocket. The only food they found in the restaurant was “Tibs” and costs 80 Birr. How could a person “A” and his/her friend eat dinner?
2. Is there another possible way for two atoms to form a covalent bond other than through the equally sharing of electrons between two atoms? Explain how.

In the previous sections, we have discussed ionic and covalent bonding. There is a third possibility in which unstable atoms becomes stable and it is by sharing electrons. However, the sharing is only from one atom. A **coordinate covalent bond** or sometimes known as a **dative bond** is a type of covalent bond where the electron pair is provided

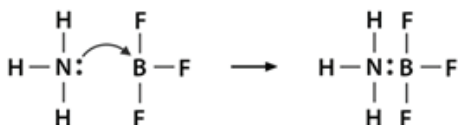
by only one of the bonded atoms but shared by both atoms after bond formation (**Figure 5.13**). The atoms are held together because both of the nuclei attract the electron pair in similar fashion to that of a covalent bond. Once the coordinate covalent bond is formed, it is impossible to distinguish the origin of the electrons. There are two necessary conditions for a coordinate covalent bond to take place:

- One of the atoms must have a pair of electrons, in most cases lone pair electrons. Examples of such molecules include  $\text{H}_2\text{O}$ ,  $\text{NH}_3$ , and  $\text{H}_2\text{S}$ .
- The other atom must have an empty space in its valence shell in order to accept a pair of electrons. Examples of such molecules include  $\text{BF}_3$ ,  $\text{AlCl}_3$ , and  $\text{H}^+$ .

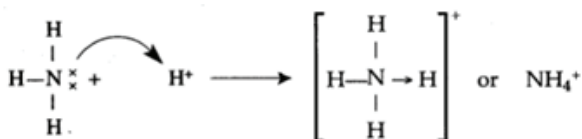


**Figure 5.13** Atomic diagram that shows the formation of coordinate covalent bond between atoms 1 and 2.

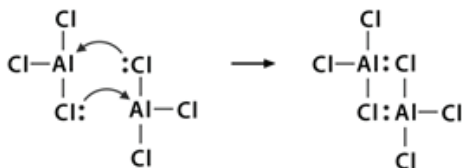
Consider the reaction between  $\text{BF}_3$  and  $\text{NH}_3$ . As we have discussed previously, boron is one of the elements that become stable without fulfilling the octet rule. In  $\text{BF}_3$ , the number of valence electrons of boron is only 6. Thus, boron has a space to hold two more electrons in its valence shell. On the other hand, in  $\text{NH}_3$ , nitrogen has a lone pair electron. Although boron trifluoride is stable, it readily forms a bond with ammonia. This reaction takes place in such a way that nitrogen shares its pair of electrons to boron forming a coordinate covalent bond as shown below. In this case, both boron and nitrogen share the shared electrons of nitrogen.



The second example of a coordinate covalent bond is the formation of ammonium ion from hydrogen ion ( $\text{H}^+$ ) and ammonia ( $\text{NH}_3$ ). The hydrogen ion has no electrons on its valence shell and can accommodate two electrons in order to fulfil the duet rule. Ammonia shares its lone pair electrons to hydrogen ions and forms a coordinate covalent bond as shown below.



The third example is the formation of  $\text{Al}_2\text{Cl}_6$ . The bonding in aluminium chloride ( $\text{AlCl}_3$ ) is essentially covalent. Each aluminium (Al) atom has a deficit of two electrons in its valance shell, and chlorine (Cl) has a lone pair. Aluminium forms a coordinate covalent bond with the Cl atom on an adjacent  $\text{AlCl}_3$  group. As each of two aluminium atoms does this, then aluminium chloride is a covalent dimer molecule with the formula  $\text{Al}_2\text{Cl}_6$ .



Although the properties of a coordinate covalent bond do not differ from those of a normal covalent bond (because all electrons are alike no matter what their source), the distinction is useful for keeping track of valence electrons.



### Exercise 5.9

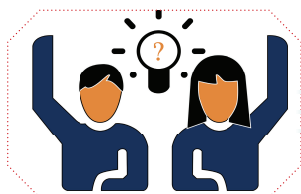
Provide the appropriate answer to the following questions.

1. Show the formation of carbon monoxide (CO) using Lewis's formula.
2. Explain the formation of hydronium ion ( $\text{H}_3\text{O}^+$ ).

### 5.3.5 General Properties of Covalent Compounds

At the end of this section, you will be able to

- ☞ explain the general properties of covalent compounds;
- ☞ investigate the properties of given samples of covalent compounds.



### Activity 5.10

Students, please form groups and discuss on the following questions. Present your discussion points to the rest of the class, when asked by your teacher.

1. Consider the covalent molecule water and the ionic compound table salt. Compare them in terms of state, melting point, boiling point and conductivity of electricity.
2. Based on the above comparison, what general properties can you suggest about covalent compounds?

In the previous sections, we have discussed that covalent compounds are formed by sharing electrons between two atoms. They have different physical and chemical

properties compared to ionic compounds. In this section, we are going to discuss about the general properties of covalent compounds.

### Physical Properties of Covalent Compounds

Covalent compounds form discrete molecules that can exist independently from each other in contrast to the crystal structure of ionic compounds in which formula units cannot exist individually but only as a part of a lattice of ions. Therefore, the physical properties of covalent molecules depend heavily on the nature of their interaction with other molecules (intermolecular forces). Depending on the nature of these intermolecular interactions, covalent compounds have the following properties.

- At room temperature, most covalent compounds are gases or liquids. Some covalent compounds are soft solids. The intermolecular force between most covalent molecules is the weak van der Waal's force and will be discussed in grade 11.
- Most covalent compounds have low melting and boiling points. The melting point and boiling point of substances are also dependent on the intermolecular forces between covalent molecules. Diamond is an exception. Its melting point is very high (about 4027 °C).
- Most covalent compounds are poor conductors of electricity. This is because they cannot form ions in their solution form or molten state. Graphite, an allotrope of carbon, has covalent bonds and is an exception as it is a good conductor. Some covalent compounds like HCl that ionise in an aqueous solution are good conductors of electricity as well.
- Most covalent compounds are soluble in non-polar solvents and are insoluble in polar solvents like water. The reason behind this is most covalent compounds are either non-polar or moderately polar. Water is a highly polar solvent and cannot dissolve non-polar or moderately polar covalent molecules. Few polar covalent compounds, however, dissolve in polar solvents such as methanol and ethanol. The principle "like dissolves like" works in the solubility of substances.
- Reactions of covalent compounds are slow compared to that of ionic compounds. This is because of the existence of bond breaking in chemical reactions wherein breaking a covalent bond needs high energy. In reactions of ionic compounds, dissolution of ionic compounds releases ions relatively easily. Hence, a relatively fast reaction occurs.
- The existence of a covalent compound in the liquid or gaseous state makes the number of molecules per unit volume less, thereby leading to low density.



### Exercise 5.10

Provide the appropriate answer to the following questions.

1. Describe the physical properties of covalent compounds.
2. Compare the physical properties of covalent compounds with ionic compounds.

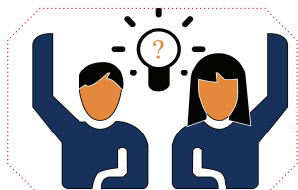
Intermolecular forces and their relationship to the states of matter will be discussed in grade 11.

## 5.4 Metallic Bonding

In the previous sections, we have discussed about the three types of bonding known as ionic, covalent and coordinate covalent. In ionic bonding, metals form a bond with non-metallic elements. In covalent bonding, non-metals share electrons. In coordinate covalent bonding, non-metallic elements share electrons but the sharing comes from one element. These, however, are not the only types of bonding atoms can form. There is a fourth type of bonding that occurs between metallic atoms. This bond unlike other types of bonds will only occur between atoms of the same element. This section, therefore, deals with the formation of metallic bonding and its properties.

### 5.4.1 Formation of Metallic Bond

At the end of this section, you will be able to discuss the formation of metallic bonds.



#### Activity 5.11

Students, please form groups and discuss the following questions. Present your discussion points to the rest of the class, when asked by your teacher.

1. Are there ionic molecules? Why?
2. Have you ever heard about metal molecules? Why?
3. Can two identical or different metal atoms form molecules?

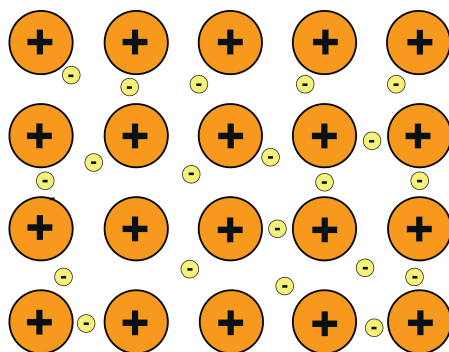
A metal atom generally has either 1, 2, or 3 electrons in its valence shell. It can easily lose these electrons and gain stability in the course of a chemical reaction. Metals are thus highly electropositive in nature. These electrons lost by the metal are called **free electrons**.

In the early 1900s, Paul Drude came up with the “**sea of electrons**” metallic bonding theory by modelling metals as a mixture of atomic cores and valence electrons. By atomic cores, he means positive nuclei and inner shell electrons. Metallic bonds occur among the same metal atoms. Ionic bonds join metals to non-metals, whereas metallic

bonding joins a bulk of metal atoms. A sheet of aluminium foil and a copper wire are good examples where you can see metallic bonding in action.

Metals have high melting and boiling points suggesting the presence of strong attraction forces between the atoms. Even a soft metal like sodium melts at a considerably higher temperature (melting point  $97.8^{\circ}\text{C}$ ) than the element (neon m.p.  $-248.6^{\circ}\text{C}$ ) which precedes it in the Periodic Table. Sodium has the electronic configuration 2,8,1. When sodium atoms come together, the electron in the outermost shell of one sodium atom shares space with the equivalent valence electron on a neighbouring atom outermost shell, in much the same way that a covalent bond is formed. The difference between a covalent bond and the metallic bond in sodium atoms, however, is that each sodium atom is being touched by eight other sodium atoms and the sharing occurs between the central atom and the outermost shell on all of the eight other atoms. Each of these eight atoms, in turn, is being touched by eight sodium atoms, which in turn are touched by eight atoms and so on and so on, until all the atoms in that lump of sodium are taken. All of the outermost shells on all of the sodium atoms overlap to give a vast number of molecular shells that extend over the lump of metal.

The electrons freely move within these molecular outermost shells, and therefore each electron becomes detached from its parent atom. The electrons are said to be delocalized. The metal is held together by the strong forces of attraction between the positive nuclei and the delocalized electrons (**Figure 5.14**).



**Figure 5.14** Metallic bonding: The Electron Sea Model: Positive atomic nuclei (orange circles) surrounded by a sea of delocalized electrons (yellow circles).

Such type of metallic bonding is sometimes described as “an array of positive ions in a sea of electrons”. Each positive centre in the diagram represents all the rest of the atom apart from the outer electron, but that electron has not been totally lost from the atoms. It may no longer have an attachment to a particular atom, but it’s still there in the structure. Sodium metal is therefore written as Na, not  $\text{Na}^+$ .

**Problem:** Discuss the metallic bonding in magnesium and explain why it has a higher melting point than sodium metal.



**Strategy:** Use the sea of electrons model to explain why magnesium has a higher melting point ( $650^{\circ}\text{C}$ ) than sodium ( $97.79^{\circ}\text{C}$ ).

### Solution

Magnesium has the electronic configuration 2, 8, 2. Both of the valence electrons become delocalized, so the “sea” has twice the electron density as it does in sodium. The remaining “ions” also have twice the charge and so there will be more and strong attraction between “ions” and “sea”. Each magnesium atom has 12 protons in the nucleus compared with sodium’s 11. In both magnesium and sodium, the nucleus is screened from the delocalized electrons by the same number (10) of electrons in the inner shells (2 + 8). This means that there will be a stronger attraction from the magnesium nucleus of  $2+$  than the sodium nucleus which has only a  $1+$  nucleus.

So, there will be a greater number of delocalized electrons in magnesium which leads to a greater attraction by the magnesium nuclei. The smaller radius of magnesium atoms leads to stronger attractions of the delocalized electrons than sodium, as they are closer to the magnesium nuclei. Each magnesium atom also has a greater number (twelve) of near neighbours than sodium (eight). These factors, therefore, increase the strength of the bond still further in magnesium metal.

Transition metals tend to have particularly high melting points and boiling points. The reason is that they can involve more valence electrons in the delocalization. The more electrons you can involve, the stronger the attractions tend to be.



### Exercise 5.11

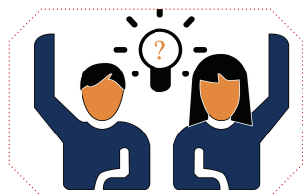
Provide the appropriate answer to the following questions.

1. Define metallic bond.
2. Discuss the metallic bond in aluminium metal. (Hint: one aluminium atom will be surrounded by 12 atoms).
3. Compare the metallic strength between magnesium and aluminium metals. Justify your answer.
4. Draw the electron sea model of magnesium metal.

## 5.4.2 Properties of Metallic Bond

At the end of this section, you will be able to

- ☞ explain the electrical and thermal conductivity of metals in relation to metallic bonding;
- ☞ make a model to demonstrate metallic bonding.



### Activity 5.12

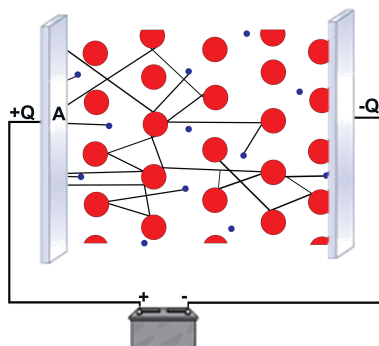
Students, please form groups and discuss the following questions. Present your discussion points to the class.

1. Which of the following substances conduct electricity? Dry cloth, plastic, dry wood, a piece of metal.
2. Of the substances listed under question number 1, what is the reason that all except one substance do not conduct electricity?
3. Which of the substances mentioned under question number 1 is the hardest? Why?

Metals have several unique qualities, such as the ability to conduct electricity and heat. Metals have other bulk properties which will be discussed in grade 10.

### Conductivity

Since the electrons in metals are free to move between the positively charged “ions”, pushing electrons from an outside source into a metal wire at one end (**Figure 5.15**) would move the free electrons through the wire and come out at the other end at the same rate. Such movement of charge is known as conductivity. These freely moving electrons transfer electric charge as well as heat across the metallic structure. This freedom of the valence electrons accounts for the high thermal conductivity in metals as well.



**Figure 5.15** The “sea of electrons” is free to flow about the crystal of positive metal ions. These flowing electrons can conduct electrical charge when an electric field is applied (e.g., a battery).



### Exercise 5.12

Provide the appropriate answer to the following questions.

1. List the properties of metals.
2. What are the three factors that determine the strength of a metallic bond?
3. Why metals have high melting and boiling points compared to the non-metals?

### Key Terms

<input type="checkbox"/> Anion	<input type="checkbox"/> Ionic bond
<input type="checkbox"/> Anode	<input type="checkbox"/> Ionic compound
<input type="checkbox"/> Bond polarity	<input type="checkbox"/> Ionization
<input type="checkbox"/> Boiling point	<input type="checkbox"/> Ionization energy
<input type="checkbox"/> Brittle	<input type="checkbox"/> Lewis formula
<input type="checkbox"/> Cation	<input type="checkbox"/> Lone pair electron
<input type="checkbox"/> Cathode	<input type="checkbox"/> Melting point
<input type="checkbox"/> Chemical bond	<input type="checkbox"/> Metallic bond
<input type="checkbox"/> Conductivity	<input type="checkbox"/> Monoatomic ion
<input type="checkbox"/> Covalent bond	<input type="checkbox"/> Multiple bond
<input type="checkbox"/> Covalent molecule	<input type="checkbox"/> Noble gases
<input type="checkbox"/> Coordinate covalent bond	<input type="checkbox"/> Nonbonding electron
<input type="checkbox"/> Diatomic molecule	<input type="checkbox"/> Nonpolar molecule
<input type="checkbox"/> Dipole	<input type="checkbox"/> Octet rule
<input type="checkbox"/> Dot formula	<input type="checkbox"/> Polar molecule
<input type="checkbox"/> Double bond	<input type="checkbox"/> Polyatomic molecule
<input type="checkbox"/> Electronegativity	<input type="checkbox"/> Polyatomic ion
<input type="checkbox"/> Homonuclear	<input type="checkbox"/> Single bond
<input type="checkbox"/> Heteronuclear	<input type="checkbox"/> Triple bond
<input type="checkbox"/> Immiscible liquids	<input type="checkbox"/> Unshared electron
<input type="checkbox"/> Ion	

### Unit Summary

In this unit, the association of the electrons and the properties of the elements in chemical bond formation are discussed thoroughly. Elements are distinguishable from each other due to their electrons. Because each element has a distinct number of electrons, this determines their chemical properties as well as the extent of their reactivity. In chemical bonding, only valence electrons are involved. This unit, therefore, dealt with the way how the different types of chemical bonds are formed, the properties of compounds formed in each type of chemical bonding, and the electron dot formulas or Lewis structures used to represent simple molecules or compounds formed in each

type of chemical bonding, and the origin of polarity in molecules.

Except a few elements, the atoms of most of the elements have a characteristic tendency to combine and form molecules or compounds. The atoms that form the molecules are held together by attractive forces. A **chemical bond** is, therefore, the force that holds atoms together to form molecules or compounds.

The American chemist Gilbert Lewis (1875-1946) used this observation to explain the types of ions and molecules that are formed by other elements. He called his explanation the **octet rule**. The **octet rule** states that atoms tend to form compounds in ways that give them eight valence electrons, and thus the electron configuration of a noble gas. Most elements follow the octet rule in chemical bonding, which means that in order to become stable an element should have eight valence electrons in a bond or exactly fill up its valence shell.

In the course of chemical bond formation, atoms attain octet by sharing, losing, or gaining valence electrons. Metals tend to lose all their valence electrons while nonmetals eight gain or share some of their valence electrons.

Any atom or molecule with a net charge, either positive or negative, is known as an **ion**. Net electric charge of an ion is calculated as follows:

$$\text{Net electric charge} = \text{number of protons} - \text{number of electrons}$$

**Anions** are atoms or group of atoms having a net negative electric charge and **cations** are atoms or group of atoms having a net positive electric charge. Ions can be formed by **ionization**, which is the process of a neutral atom **losing or gaining its valence electrons**.

A bond formed by two oppositely charged ions due to electrostatic force is known as an **ionic bond**. The process of forming such a bond is called **ionic bonding**. As a general rule, ionic bond is formed between metallic and non-metallic elements.

To explain the various types of bonds and to visualise the change in the valence electrons, the American physical chemist Gilbert N. Lewis (1916) proposed the **Lewis dot formula**. In the Lewis symbol for an atom, the chemical symbol of the element with their valence electrons is represented as dots surrounding it. The Lewis dot formula can also be represented using the atomic diagram.

The properties of ionic compounds depend on how strongly the cations and anions attract each other in an ionic bond. Ionic compounds exhibit the following properties:

- ☞ They form crystals: the opposite charged ions in ionic compounds are held together very strongly by electrostatic force of attraction. Hence the ionic compounds are generally hard solids.
- ☞ They have high melting and high boiling points: considerable heat energy is required to separate the strong electrostatic attraction force between the

positive and negative ions in ionic compounds.

- ☞ They are hard and brittle: ionic crystals are hard because the positive and negative ions are strongly held together by electrostatic attraction force.
- ☞ They are soluble in polar solvents: polar solvents dissolve polar compounds. A polar solvent is a type of solvent that has large partial charges or dielectric constant.
- ☞ They conduct electricity when they are dissolved in water or in a molten state: melting and dissolving ionic compounds makes cations and anions free to move.
- ☞ They have high density: the number of ions per unit volume in an ionic compound is high.

A **covalent bond** consists of the simultaneous attraction of two nuclei for one or more pairs of electrons. In other words, a covalent bond is formed when two atoms share one or more electron pairs. Based on the number of pairs of shared electrons, the covalent bonds formed can be classified into three:

- ☞ **Single bond:** one pair of electrons is shared
- ☞ **Double bond:** share two pairs of electrons and
- ☞ **Triple bond:** share three pairs of electrons

In a hetero nuclear molecule like HF, the shared electron pair between the two atoms gets displaced more towards fluorine since the electronegativity of fluorine is far greater than that of hydrogen. The resultant covalent bond is a **polar covalent bond**. The molecule is termed as **polar molecule**. An ionic bond results when the electronegativity difference between the two bonding atoms is 2.0 or more. A polar covalent bond forms when the electronegativity difference between the atoms is in the range 0.5-2.0.

A **coordinate covalent bond** or sometimes known as a dative bond is a type of covalent bond where the electron pair is provided by only one of the bonded atoms but shared by both atoms after bond formation. Once the coordinate covalent bond is formed, it is impossible to distinguish the origin of the electrons.

Depending on the nature of intermolecular interactions, covalent compounds have the following properties:

- ☞ At room temperature, most covalent compounds are gases or liquids
- ☞ Most covalent compounds have low melting and boiling points
- ☞ Most covalent compounds are poor conductors of electricity
- ☞ Most covalent compounds are soluble in non-polar solvents and are insoluble in polar solvents like water
- ☞ Reactions of covalent compounds are slow compared to that of ionic compounds
- ☞ The existence of a covalent compound in the liquid or gaseous state makes the number of molecules per unit volume less, thereby leading to low density

In the early 1900s, Paul Drude came up with the “sea of electrons” metallic bonding theory by modelling metals as a mixture of atomic cores and valence electrons. By

## Chemistry Grade 9

atomic cores, he means positive nuclei and inner shell electrons. Metallic bonds occur among the same metal atoms. In metallic bonding the metal is held together by the strong forces of attraction between the positive core and the delocalized valence electrons of the metal. Metals have several unique qualities, such as the ability to conduct electricity and heat.

### Review Exercise

#### Part I: Basic level questions.

Choose the correct answer for the following questions.

- Which of the following does not contain ionic bonds?
  - Sulfur dioxide
  - Sodium oxide
  - Silicon dioxide
  - Silver oxide
- Which of the substances has ions in its bonding model?
  - Copper
  - Carbon dioxide
  - Copper oxide
  - Carbon
- Which of the following is ionic compounds?
  - HCl
  - NaCl
  - CO<sub>2</sub>
  - HBr
- Which of the following doesn't follow octet rule?
  - CH<sub>4</sub>
  - CCl<sub>4</sub>
  - BCl<sub>3</sub>
  - CO<sub>2</sub>
- Which of the following compounds contain hydrogen bonding?
  - H<sub>2</sub>O
  - NH<sub>3</sub>
  - HF
  - CCl<sub>4</sub>

#### Part II: Intermediary level questions.

Tell whether the following statements are true or false.

- An Octet rule states that an element should have eight valence electrons in a bond or exactly fill up its valence shell.
- Many elements in the third-row and beyond have been observed to form compounds in which the central atom is surrounded by more than eight electrons.
- An ionic compound is denoted by writing its net negative charge in superscript immediately after the chemical structure for the atom/molecule.
- Ions can be formed by ionization, which is the process of a neutral atom losing or gaining electrons.
- As a general rule, ionic bond is formed between non-metallic elements.
- An ionic bond forms when the electronegativity difference between the two bonding atoms is less than 2.0.
- The properties of covalent compounds relate to how strongly the positive and negative ions attract each other in a covalent bond.
- Most of the ionic compounds are crystalline solids.
- Considerable heat energy is required to separate the strong electrostatic attraction force between the positive and negative ions in ionic compounds.

- The number of bonds that an atom can form can often be predicted from the number of electrons needed to reach an octet.
- A non-polar covalent bond forms when the electronegativity difference between the atoms is in the range of 0.5-2.0.
- Once the covalent bond is formed, it is possible to distinguish the origin of the electrons.

**Fill in the blank spaces.**

- There are two ways in which atoms can satisfy the octet rule. One way is by \_\_\_\_\_ their valence electrons with other atoms. The second way is by \_\_\_\_\_ valence electrons from one atom to another.
- Losing, gaining or sharing of the valence electrons is always accompanied by \_\_\_\_\_.
- Atoms of \_\_\_\_\_ tend to lose all of their valence electrons, which leave them with an octet from the next lowest principal energy level.
- Any atom or molecule with a net charge, either positive or negative, is known as \_\_\_\_\_.
- A bond formed by two oppositely charged ions due to electrostatic force is known as \_\_\_\_\_.
- In the \_\_\_\_\_ for an atom, the chemical symbol of the element is written, and the valence electrons are represented as dots surrounding it.
- Polar solvents dissolve polar compounds and non-polar solvents dissolve non-polar compounds. This is commonly referred to as \_\_\_\_\_.
- Bonds sharing more than one pair of electrons are called \_\_\_\_\_.
- \_\_\_\_\_ occur between identical atoms or between different atoms whose difference in electronegativity is insufficient to allow the transfer of electrons to form ions.
- Only atoms of the same element, which have the same electronegativity, can be joined by a \_\_\_\_\_ bond.
- A property that helps us distinguish a non-polar covalent bond from a polar covalent bond is \_\_\_\_\_.
- When molecules share electrons equally in a covalent bond, there is no net electrical charge across the molecule. Such type of covalent molecule is known as \_\_\_\_\_ molecule.
- A \_\_\_\_\_ is a type of covalent bond where the electron pair is provided by only one of the bonded atoms but shared by both atoms after bond formation.

**Part III: Challenge level questions****Give appropriate answers to the following questions.**

- How many types of chemical bonds are there? What are they?
- Name one solvent in which most of the ionic compounds dissolve.
- In which state do ionic compounds conduct electricity?

34. Why do the nonpolar covalent compounds not conduct electricity?
35. What type of chemical bonds are found in each of the following compounds?
  - a. Potassium chloride
  - b. Carbon dioxide
  - c. Hydrogen chloride
  - d. Water
  - e. Magnesium oxide
  - f. Calcium fluoride
  - g. Methane
  - h. Sodium chloride
  - i. Ammonia
  - j. Phosphorus pentachloride
  - k. Sulphur hexachloride
36. In what type of solvents do the a) polar compounds and b) nonpolar compounds dissolve?
37. Why are molecules more stable than atoms?
38. What are the criteria due to which a covalent bond becomes polar or nonpolar?
39. Why are the partial positive and negative charge developed within a polar covalent molecule?
40. What is a coordinate covalent bond?
41. What are van der Waal's forces of attraction?
42. Define a) polar covalent compound and b) nonpolar covalent compound.
43. Give some examples in which coordinate covalent bond formation takes place.
44. Why do metals lustre?
45. Give some examples of the compounds where hydrogen bond exists.
46. Draw the Lewis dot formulae for the bond formations in the following compounds.
  - a. NaCl
  - b. CaF<sub>2</sub>
  - c. H<sub>2</sub>
  - d. O<sub>2</sub>
  - e. N<sub>2</sub>
  - f. H<sub>2</sub>O
  - g. NH<sub>3</sub>
  - h. CH<sub>4</sub>
47. What are the factors responsible for the formation of covalent bond and ionic bond?
48. Why do the noble gases not take part in a chemical reaction?
49. What type of bond formation takes place between a) a metal and a nonmetal and b) two nonmetals?
50. Why do most of the ionic compounds exist in solid state while the covalent compounds are mostly in gaseous or liquid state?
51. What is the role of ionization potential and electron affinity of the elements in the formation of ionic bond and covalent bond?
52. Why is the density of ionic compounds high and that of covalent compounds low?
53. Why are the melting points and boiling points of the ionic compounds high and those of covalent compounds low?
54. Why do the pure covalent compound not conduct electricity?
55. Why are the ionic compounds soluble in water?
56. Why do polar covalent compounds dissolve in water?
57. What types of bonds exist in the following ions? a) ammonium ion b) hydronium ion?